

Best choice.

Vágás. Élhajlítás. Automatizálás.

Bystronic

Bystronic szerszámok RF-AC szerszámaink

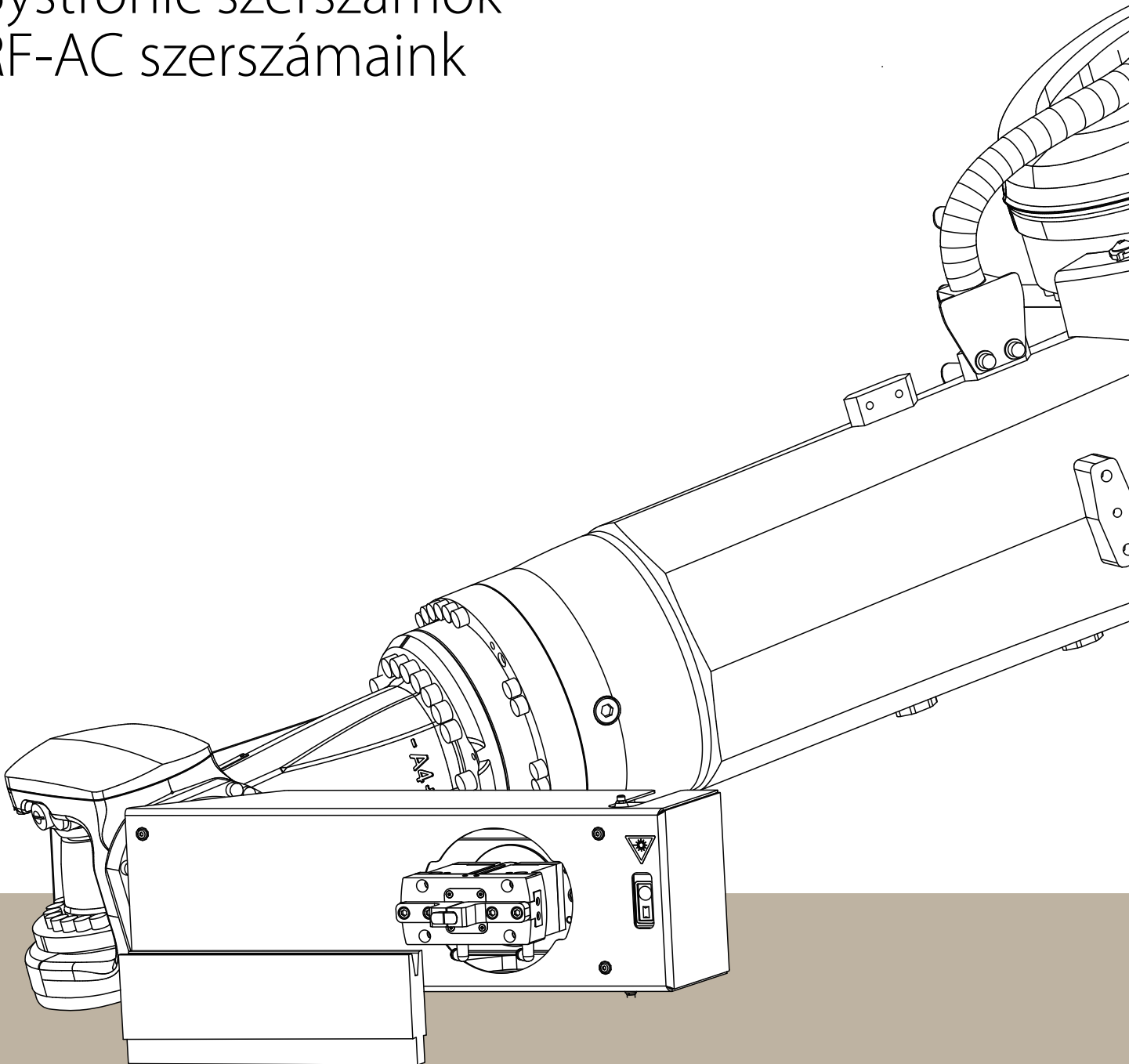



Tartalomjegyzék

Alapok	3
A katalógus ikonjai	3
A léghajlítás számítási alapjai.....	4
Hogyan működik a szerszámcsere?	8
Hornyok.....	9
Szegmentálás	10
Felső szerszámok	14
Felső szerszám szegmensek.....	16
Alsó szerszámok	22
Alsó asztali opciók	24
Alsó szerszám szegmentálása	25
Hamming szerszámok	60
Kapcsolatfelvételi adatok világszerte ..	70



Alapok

A katalógus ikonjai



Keménység: 58–62 HRC



Max. megengedett terhelés



Max. megengedett dobozmélység



Tömeg



Megfordítható szerszám

A katalógus az alábbi gépeket tárgyalja:

Xpert Tool Changer - XTC

Modular Tool Changer - MTC

Bending Cell - BC



A léghajlítás számítási alapjai

A léghajlítás kapacitástáblázata

A megadott adatokat $R_m = 420 \text{ N/mm}^2$ szakítószilárdságú, 1 m hosszúságú hajlítóanyag alapján számították ki.

V	6	8	10	12	16	18	20	24	32	40	50	60	80	
R	1	1,2	1,6	2	2,5	2,8	3	3,5	5	6	8	9,5	12	
t	F	Hajlítóerő erő kN/1 m hajlítási hosszban kifejezve												
	a	Minimális karimahossz mm-ben												
0,5	25													
	4,3													
0,8	70	48												
	4,6	5,7												
1	115	80	60											
	5	6	7											
1,2		120	90	70										
		6	7,5	8,5										
1,5			150	120										
			8	9										
2,0				235	160	135	120	95						
				10	12	13	14,5	17						
2,5					265	225	200	155	110					
					12,5	14	15,5	17,5	23					
3,0							300	240	165	125				
							15,5	17,5	23,5	28				
4,0									315	235	180			
									25	29	35			
5,0									535	430	310	250		
									26	31	35,5	43		
6,0										610	450	360		
										32	36	44		
8,0											880	690	470	
											40	46	57	
10													800	
														60
12														1200
														62
16														
18														
20														

A hengerlési revével szennyezett lemezek 1,05–1,1-szeresére növelik a hajlítóerőt



100	120	130	140	150	160	180	190	200	230	260	290	320	V
15,5	19	21	23	24,5	26	28	30	32	36	40	45	50	R
F	Hajlítóerő erő kN/1 m hajlítási hosszban kifejezve												t
a	Minimális karimahossz mm-ben												
													0,5
													0,8
													1
													1,2
													1,5
													2,0
													2,5
													3,0
													4,0
													5,0
													6,0
360													8,0
71													10
600	470	430	390										12
71	85	92	100										16
900	710	650	580	550	500								18
73	86	92	100	105	115								20
	1400	1250	1150	1050	950	810	800	710	600				
	90	98	105	110	115	130	135	140	160				
			1480	1350	1250	1100	1000	950	800	700	600		
			105	110	120	130	135	140	160	180	205		
						1400	1300	1200	1000	900	850	700	
						135	140	145	165	180	205	225	

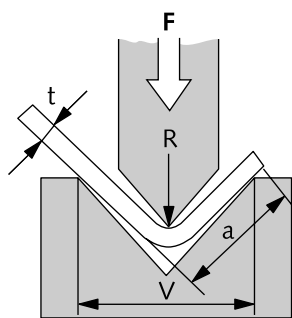

Az R belső sugár a V szerszámnyílás körülbelül 16%-ának felel meg.



A léghajlítás számítási alapjai

Számítási képletek

Ajánlott V alsó szerszámnyílás léghajlításhoz

Anyagvastagság	t	0,5–2,5 mm	3–8 mm	9–10 mm	> 12 mm
Alsó szerszámnyílás	V	6 × t	8 × t	10 × t	12 × t

Hajlítóerő

Alumínium	Rm = 300 N/mm ²	F = F (táblázat) × 0,65
Lágyacél	Rm = 420 N/mm ²	F = F (táblázat)
Nemesacél	Rm = 700 N/mm ²	F = F (táblázat) × 1,6

A hajlítóerő meghatározása léghajlítás esetén (referenciaadatok)

$$F = \frac{R_m \times t^2}{V} \times \left(1 + \frac{4 \times t}{V}\right)$$

Átalakítás: Rm = szakítószilárdság N/mm²-ben

10 N = 1 kg

10 kN = 1 t

Átalakítás a minimális belső R sugarakra

vastagság t	1	2	3	4	5	6	8	10	12	16	18	20
min. R	1	2	3	5	6	8	12	16	20	28	36	40



Szakítószilárdság

Anyag		Szakítószilárdság	
Amerikai	Európai	KPSI	N/mm ²
6061 alumínium	Alu 50	42	290
5052 alumínium	Alu 35	44	303
1010 lágyacél	DC01	53	366
A536-80 G 60-40-18	GGG-40	58	400
A 351 G CF 8	G-X 6CrNi 18 9	65	450
A 572 G50	S 355 MC	80	550
Domex 80	S 420 MC	80	550
A 36	S 235 JR	80	552
304 rozsdamentes	Inox V2A	85	586
316 rozsdamentes	Inox V4A	87	600
A 572 G 65	S 460 MC	95	655
Domex 100	S 500 MC	102	700
Domex 550	S 550 MC	110	760
Domex 600	S 600 MC	119	820
Weldox 700	Weldox 700	123	850
Domex 650	S 650 MC	128	880
Domex 700	S 700 MC	138	950
4140 gyengén ötvözött	42 CrMo 4	145	1000
Weldox 900	Weldox 900	149	1030
Weldox 960	Weldox 960	154	1060
Hardox 400	Hardox 400	181	1250
Hardox 500	Hardox 500	225	1550

A nagy szilárdságú anyagok hajlításával kapcsolatban kérdezze meg felelős tanácsadóját.



Hogyan működik a szerszámcsere?

Intelligens automatizálás a gyors és precíz szerszámcsereért

- Takarítson meg időt, és növelje az élhajlítás minőségét a felső és alsó szerszámok automatikus cseréje révén
- A szerszámkészletek pontos és hibamentes elhelyezése a felső és alsó oszlopok befogórendszerében, nagy szerszámok esetén is (BC esetén V80, MTC esetén V120 értékig)
- Egyszerű szerszám bővítés bármikor: az intelligens érzékelőtechnológia automatikusan felismeri az új szerszámokat és integrálja azokat a szerszám tárbba
- A felső szerszámok automatikus váltása növeli a hajlítási műveletek sokféleségét
- Magas fokú ergonómia és kompakt kezelhetőség, hiszen minden szerszám készen áll a gépen belül
- A hajlított munkadarabok precíz és finom kezelése a hajlítóasztalról történő automatikus eltávolítás révén



* Maximális szerszámsúly:

Gripper XTC	- max. 15,0 kg
Gripper BC/MTC	- max. 25,0 kg



Hornyok

Felső szerszámok

A felső szerszámok hátoldalán hornyok helyezkednek el. Az aszimmetrikus bélyegek előoldalán, mint pl. a P4 és a P5, szintén hornyok találhatók.

A P2, P3, P4, P5, P6, P7, P8, P9, P11 és P900 típusú bélyegek (250 mm magas) használata lehetséges. Igény szerint 350 mm magas szerszámozás is elérhető.

30 mm – 515 mm* szegmenshossz.

Alsó szerszámok

Az alsó szerszámok hátoldalán hornyok helyezkednek el. A robot ezek segítségével tudja kezelni a szerszámokat.

V6–V120 szerszámbetétek használata lehetséges**.

50 mm – 515 mm* szegmenshossz.

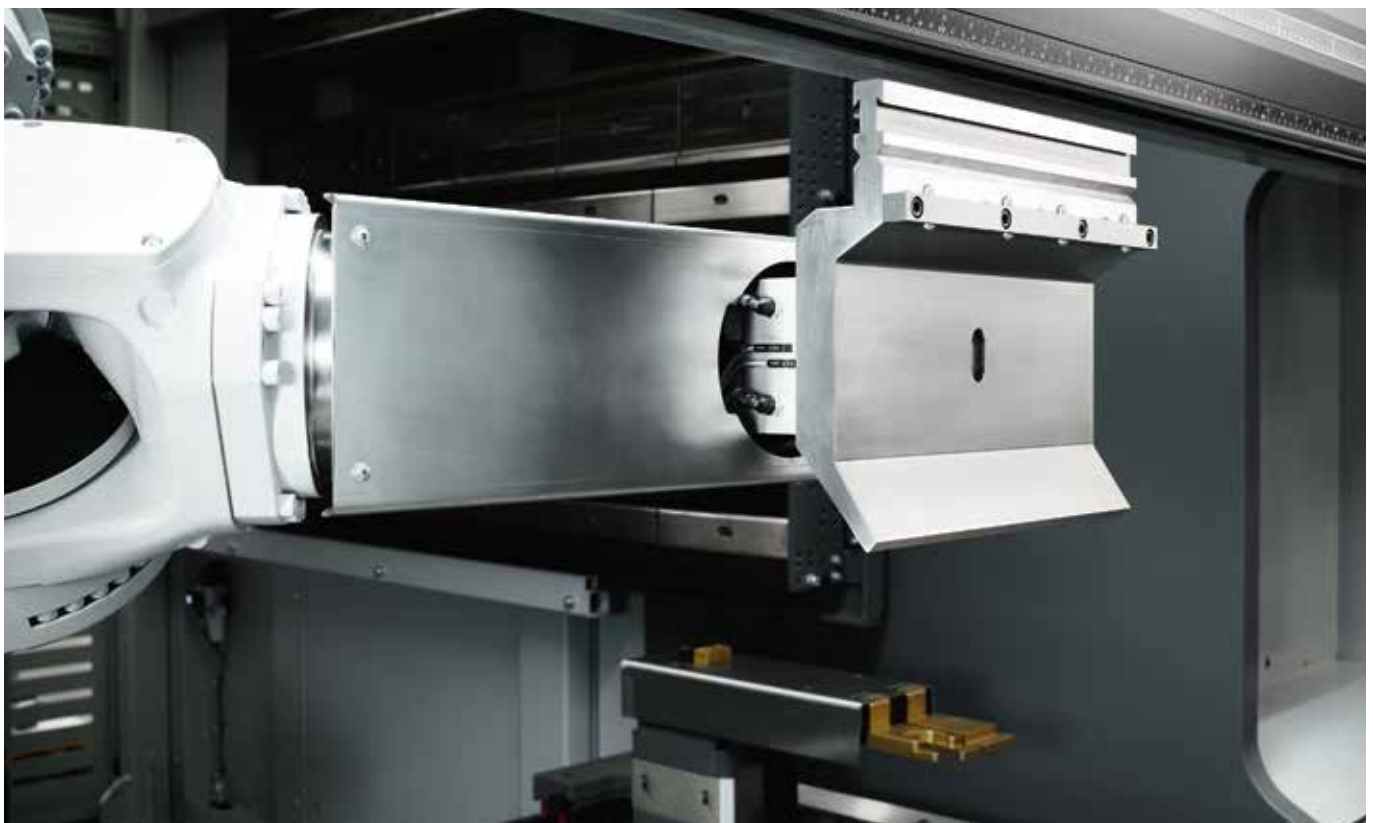

* kb. 515 mm méretű munkadarabok igény szerint vagy a BC/MTC gépeken elérhetők

** az XTC V80 méretig tudja kezelni a szerszámbetéteket
a BC/MTC V120 méretig tudja kezelni a szerszámbetéteket



Szegmentálás

Xpert Tool Changer, MTC és BC esetén

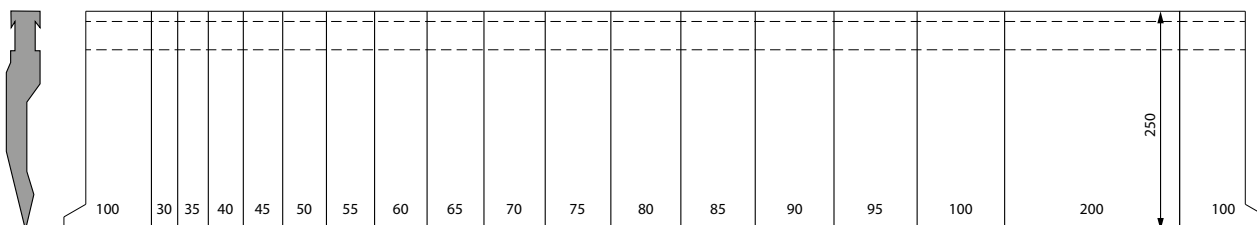

Felső szerszámok	Cikkszám
P2 RF-AC/85° bélyeg M=250 H=1375 szek.	65208.0002.5000
P4 RF-AC/85° bélyeg M=250 H=1375 szek.	65208.0004.5000
P5 RF-AC/30° bélyeg M=250 H=1375 szek.	65208.0005.5000
P7 RF-AC/30° bélyeg M=250 H=1375 szek.	65208.0007.5000

Az alábbi hosszak érvényesek a szegmentálásokra:

30 mm, 35 mm, 40 mm, 45 mm, 50 mm, 55 mm, 60 mm, 65 mm, 70 mm, 75 mm, 80 mm, 85 mm, 90 mm, 95 mm, 100 mm, szarv készlet 100 mm balos + jobbos

Felső szerszámok	Cikkszám
P11 RF-AC bélyeg Szé=20 M=250 H=1175 szek.	65208.0011.5000

Az alábbi hosszak érvényesek a szegmentálásokra:

30 mm, 35 mm, 40 mm, 45 mm, 50 mm, 55 mm, 60 mm, 65 mm, 70 mm, 75 mm, 80 mm, 85 mm, 90 mm, 95 mm, 100 mm, 200 mm

Alsó szerszámok	Cikkszám
V-Flat B40 szerszámbeállítás H=1025 szek.	65208.0000.5000

Az alábbi hosszak érvényesek a szegmentálásokra:

50 mm, 55 mm, 60 mm, 65 mm, 70 mm, 75 mm, 80 mm, 85 mm, 90 mm, 95 mm, 100 mm, 200 mm

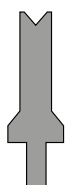

50	55	60	65	70	75	80	85	90	95	100	200

Alsó szerszámok		Cikkszám
V6C/30° szerszámbetét	H=1025 szek.	64208.0006.5000
V8C/30° szerszámbetét	H=1025 szek.	64208.0008.5000
V10C/30° szerszámbetét	H=1025 szek.	64208.0010.5000
V12C/30° szerszámbetét	H=1025 szek.	64208.0012.5000
V16C/30° szerszámbetét	H=1025 szek.	64208.0020.5000
V20C/30° szerszámbetét	H=1025 szek.	64208.0020.5000
V24C/30° szerszámbetét	H=1025 szek.	64208.0024.5000
V32C/30° szerszámbetét	H=1025 szek.	64208.0032.5000
V40C/60° szerszámbetét	H=1025 szek.	64208.0040.5000
V50C/60° szerszámbetét	H=1025 szek.	64208.0050.5000
V60C/60° szerszámbetét	H=1025 szek.	64208.0060.5000
V80C/80° szerszámbetét	H=1025 szek.	64208.0080.5000
V100C/80° szerszámbetét	H=1025 szek.	64208.0100.5000
V120C/80° szerszámbetét	H=1025 szek.	64208.0120.5000
V6SC/30° szerszámbetét	H=1025 szek.	64208.0006.5100
V8SC/30° szerszámbetét	H=1025 szek.	64208.0008.5100
V10SC/30° szerszámbetét	H=1025 szek.	64208.0010.5100
V12SC/30° szerszámbetét	H=1025 szek.	64208.0012.5100

Az alábbi hosszak érvényesek a szegmentálásokra:

50 mm, 55 mm, 60 mm, 65 mm, 70 mm, 75 mm, 80 mm, 85 mm, 90 mm, 95 mm,
100 mm, 200 mm

*** Alsó szerszámok V80 méretig XTC esetén**
Alsó szerszámok V120 méretig BC/MTC esetén



Szegmentálás

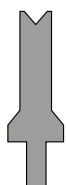

50	55	60	65	70	75	80	85	90	95	100	200

Alsó szerszámok	Cikkszám
V6C/30° szerszámbetét M=100 H=1025 szek.	64208.0006.5031
V8C/30° szerszámbetét M=100 H=1025 szek.	64208.0008.5165
V10C/30° szerszámbetét M=100 H=1025 szek.	64208.0010.5031
V12C/30° szerszámbetét M=100 H=1025 szek.	64208.0012.5030
V16C/30° szerszámbetét M=100 H=1025 szek.	64208.0020.5040
V20C/30° szerszámbetét M=100 H=1025 szek.	64208.0020.5030
V24C/30° szerszámbetét M=100 H=1025 szek.	64208.0024.5031
V32C/30° szerszámbetét M=100 H=1025 szek.	64208.0032.5030
V40C/60° szerszámbetét M=100 H=1025 szek.	64208.0040.5030
V50C/60° szerszámbetét M=100 H=1025 szek.	64208.0050.5030
V60C/60° szerszámbetét M=100 H=1025 szek.	64208.0060.5030
V80C/80° szerszámbetét M=100 H=1025 szek.	64208.0080.5030

Az alábbi hosszak érvényesek a szegmentálásokra:

50 mm, 55 mm, 60 mm, 65 mm, 70 mm, 75 mm, 80 mm, 85 mm, 90 mm, 95 mm,
100 mm, 200 mm

*** Alsó szerszámok V80 méretig XTC esetén**
Alsó szerszámok V120 méretig BC/MTC esetén





Felső szerszámok

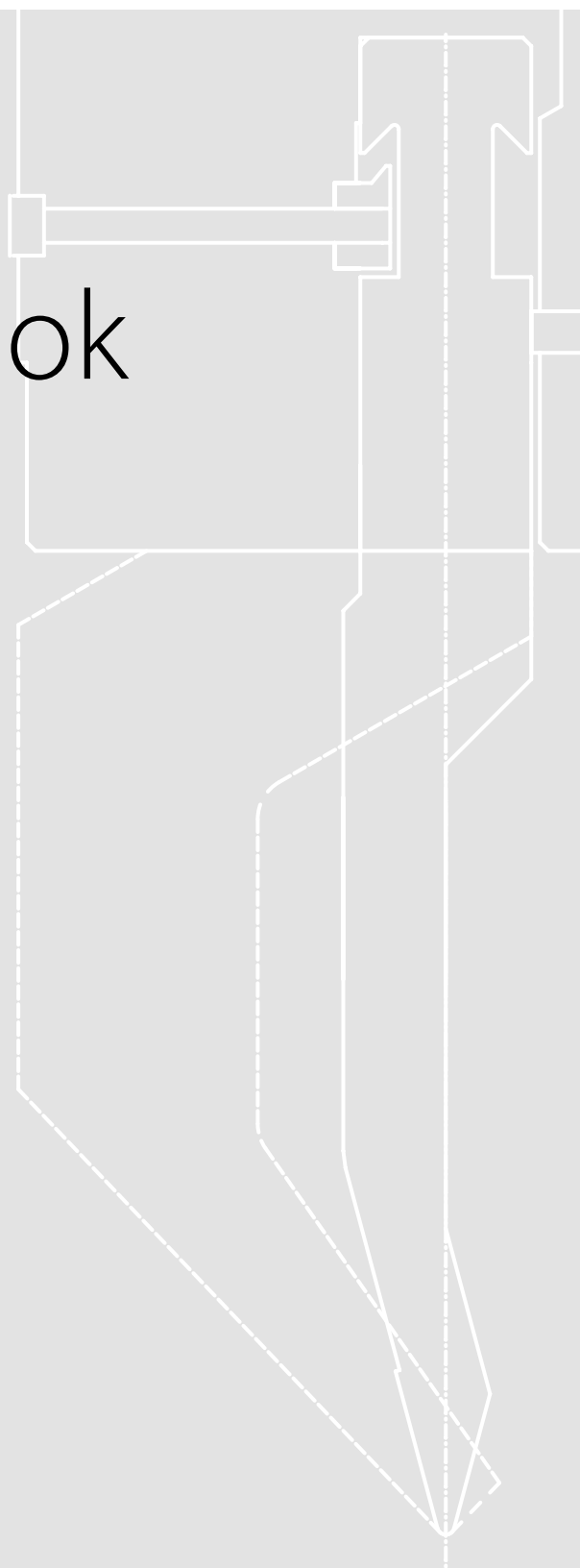





Felső szerszám szegmensek

RF-AC szarvak

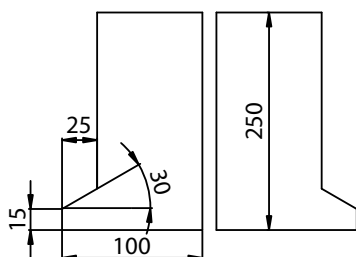

RF-AC bélyeg H= 1375 szek.

(30+35+40+45+50+60+65+70+75+80+85+90+95+100+200 +szarvak b+j)

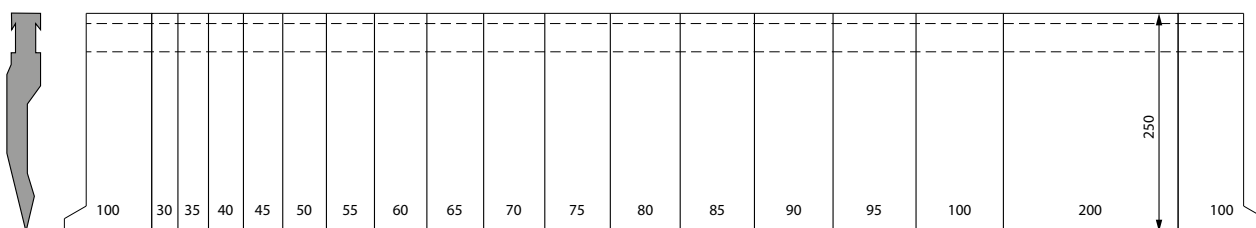

Eltérő szegmentálás kérésre.

További felső szerszámok egyéb sugárral igény szerint elérhetők.

Maximális szerszámsúly:

Gripper XTC - max. 15,0 kg

Gripper BC/MTC - max. 25,0 kg



Modular Tool Changer



Bending Cell





P2 RF-AC/85° H250

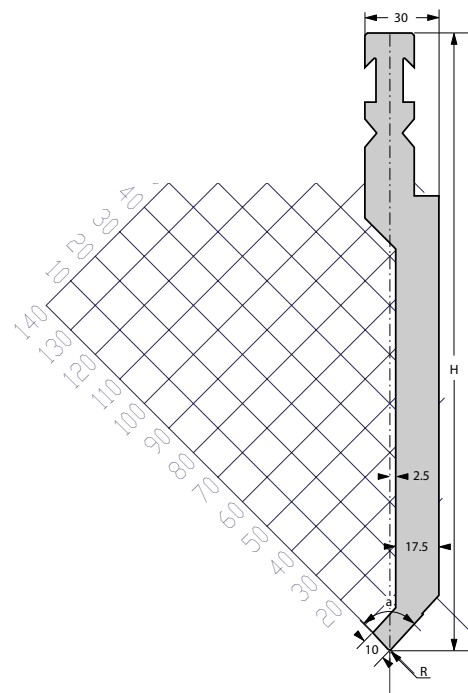

[R] Sugár (mm)*	1,0
Csúcsszög	85°
[H] Magasság (mm)	250

*egyéb sugarak igény szerint

Standard hosszúság	Cikkszám
30 mm	65208.0002.5001
35 mm	65208.0002.5002
40 mm	65208.0002.5003
45 mm	65208.0002.5004
50 mm	65208.0002.5005
55 mm	65208.0002.5006
60 mm	65208.0002.5007
65 mm	65208.0002.5008
70 mm	65208.0002.5015
75 mm	65208.0002.5016
80 mm	65208.0002.5017

Standard hosszúság	Cikkszám
85 mm	65208.0002.5018
90 mm	65208.0002.5019
95 mm	65208.0002.5020
100 mm	65208.0002.5011
200 mm	65208.0002.5012
275 mm	65208.0002.5013
300 mm	65208.0002.5014
515 mm	65208.0002.5019
Szarvkészlet, balos + jobbos	65208.0002.7001
Szarv, balos	65208.0002.7002
Szarv, jobbos	65208.0002.7003

F_{max} = 1000 kN/m

34,4 kg/m



98,0 mm



P4 RF-AC/85° H250

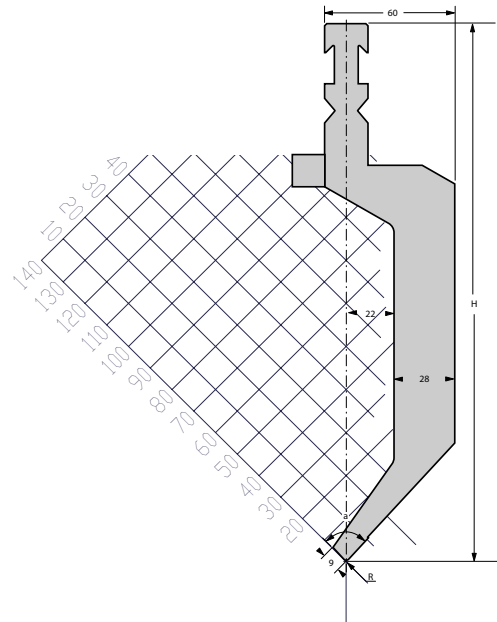

[R] Sugár (mm)*	1,5
Csúcsszög	85°
[H] Magasság (mm)	250

*egyéb sugarak igény szerint

Standard hosszúság	Cikkszám
30 mm	65208.0004.5001
35 mm	65208.0004.5002
40 mm	65208.0004.5003
45 mm	65208.0004.5004
50 mm	65208.0004.5005
55 mm	65208.0004.5006
60 mm	65208.0004.5007
65 mm	65208.0004.5008
70 mm	65208.0004.5015
75 mm	65208.0004.5016
80 mm	65208.0004.5017

Standard hosszúság	Cikkszám
85 mm	65208.0004.5018
90 mm	65208.0004.5019
95 mm	65208.0004.5020
100 mm	65208.0004.5011
200 mm	65208.0004.5012
275 mm	65208.0004.5013
300 mm	65208.0004.5014
Szarvkészlet, balos + jobbos	65208.0004.7003
Szarv, balos	65208.0004.7001
Szarv, jobbos	65208.0004.7002



F max = 600 kN/m



48,3 kg/m



98,0 mm



P5 RF-AC/30° H250

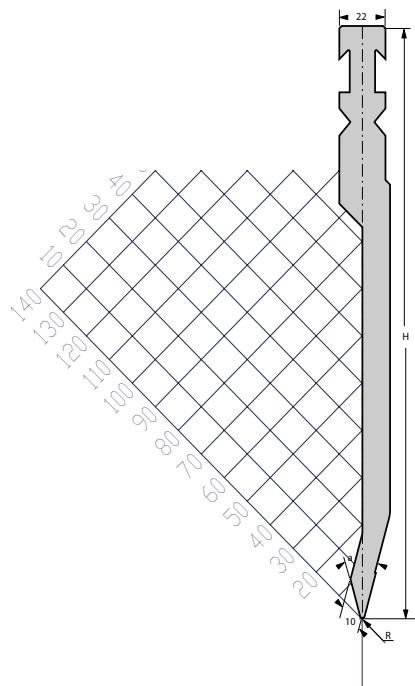

[R] Sugár (mm)*	1
Csúcsszög	30°
[H] Magasság (mm)	250

*egyéb sugarak igény szerint

Standard hosszúság	Cikkszám
30 mm	65208.0005.5001
35 mm	65208.0005.5002
40 mm	65208.0005.5003
45 mm	65208.0005.5004
50 mm	65208.0005.5005
55 mm	65208.0005.5006
60 mm	65208.0005.5007
65 mm	65208.0005.5008
70 mm	65208.0005.5015
75 mm	65208.0005.5016
80 mm	65208.0005.5017

Standard hosszúság	Cikkszám
85 mm	65208.0005.5018
90 mm	65208.0005.5019
95 mm	65208.0005.5020
100 mm	65208.0005.5011
200 mm	65208.0005.5012
275 mm	65208.0005.5013
300 mm	65208.0005.5014
515 mm	65208.0005.5021
Szarvkészlet, balos + jobbos	65208.0005.7003
Szarv, balos	65208.0005.7001
Szarv, jobbos	65208.0005.7002

F_{max} = 750 kN/m

26,0 kg/m



98,0 mm



P7 RF-AC/30° H250

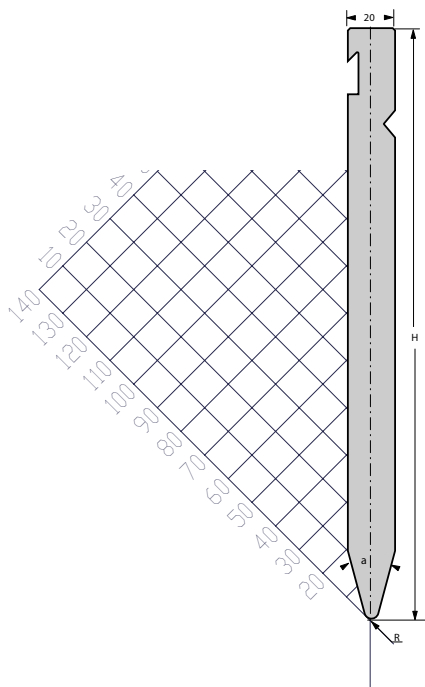

[R] Sugár (mm)*	3
Csúcsszög	30°
[H] Magasság (mm)	250

*egyéb sugarak igény szerint

Standard hosszúság	Cikkszám
30 mm	65208.0007.5001
35 mm	65208.0007.5002
40 mm	65208.0007.5003
45 mm	65208.0007.5004
50 mm	65208.0007.5005
55 mm	65208.0007.5006
60 mm	65208.0007.5007
65 mm	65208.0007.5008
70 mm	65208.0007.5015
75 mm	65208.0007.5016
80 mm	65208.0007.5017

Standard hosszúság	Cikkszám
85 mm	65208.0007.5018
90 mm	65208.0007.5019
95 mm	65208.0007.5020
100 mm	65208.0007.5011
200 mm	65208.0007.5012
275 mm	65208.0007.5013
300 mm	65208.0007.5014
515 mm	65208.0007.5026
Szarvkészlet, balos + jobbos	65208.0007.7003
Szarv, balos	65208.0007.7001
Szarv, jobbos	65208.0007.7002



F max = 1400 kN/m



35,9 kg/m



98,0 mm



Alsó szerszámok

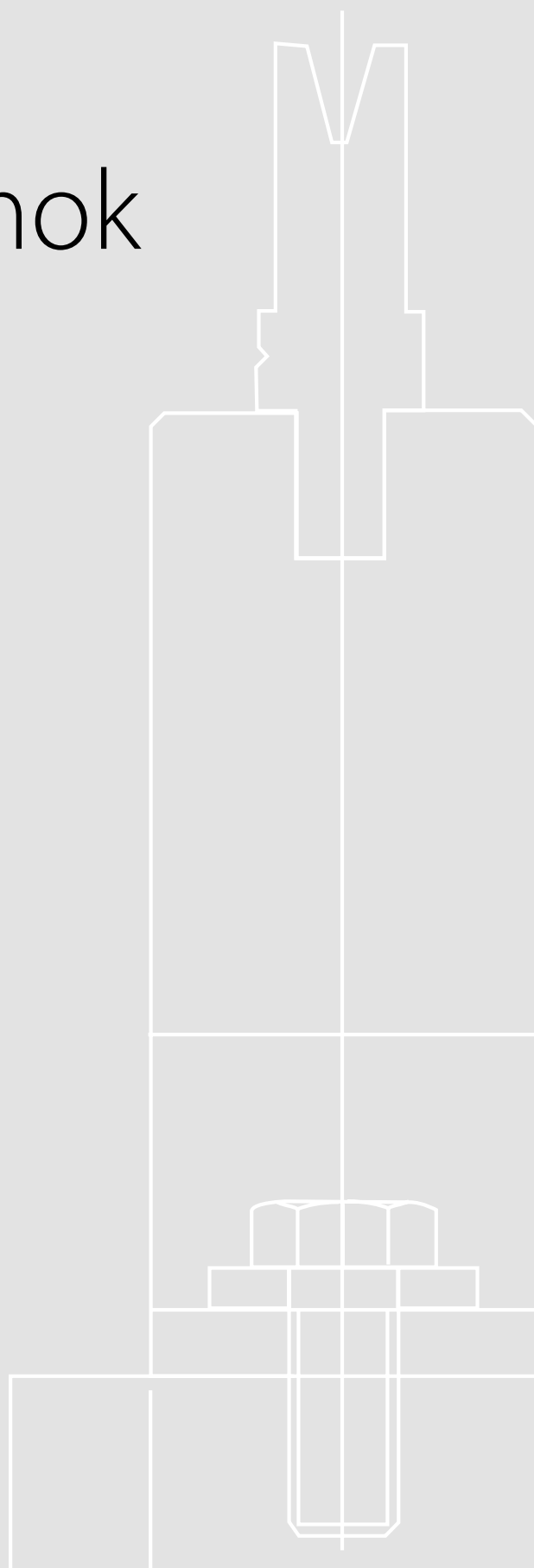





Alsó asztali opciók

Asztal hidraulikus szerszámbe fogással

T12

(Optional Xpert 60 - 320 és
Xpert 250 - 1000)

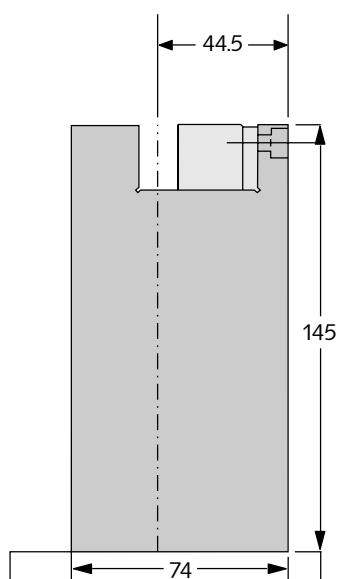

T13

(Optional Xpert 60 - 320 és
Xpert 250 - 1000)

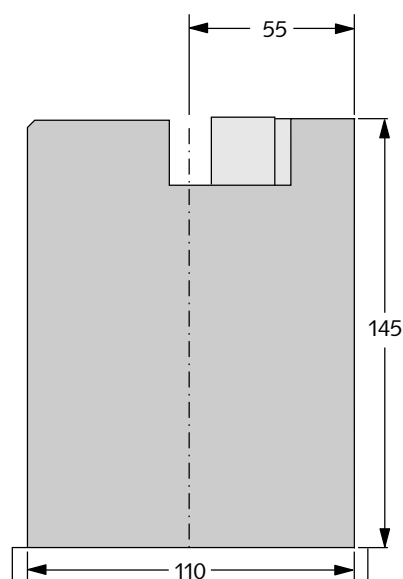



Alsó szerszám szegmentálása

VC szerszámvetét H = 1025 szek.



50	55	60	65	70	75	80	85	90	95	100	200

Különleges szegmentálás kérésre.

Ezenkívül minden alsó szerszám szállítható módosított sugarakkal, szerszámszöggel és magassággal (nem standard).



V6C/30° H55

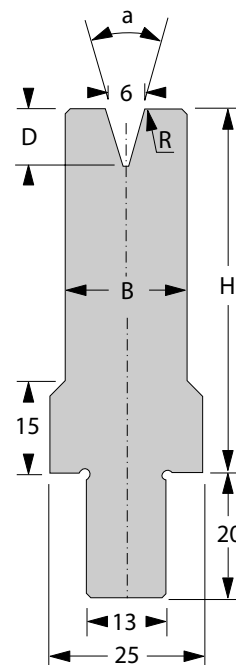

[R] Sugár (mm)*	0,75
[a] V – Szög	30°
[H] Magasság (mm)	55

[B] Szélesség (mm)	20
[D] Mélység (mm)	9,3

*egyéb sugarak igény szerint

Standard hosszúság	Cikkszám
50 mm	64208.0006.5001
55 mm	64208.0006.5002
60 mm	64208.0006.5003
65 mm	64208.0006.5004
70 mm	64208.0006.5005
75 mm	64208.0006.5006
80 mm	64208.0006.5007
85 mm	64208.0006.5008
90 mm	64208.0006.5009
95 mm	64208.0006.5010
100 mm	64208.0006.5011

Standard hosszúság	Cikkszám
200 mm	64208.0006.5012
275 mm	64208.0006.5013
300 mm	64208.0006.5014
515 mm	64208.0006.5015
1025 mm szek.	64208.0006.5000



F max 30° = 400 kN/m



10,9 kg/m



Szerszámbetét 13 mm



V6C/30° H100

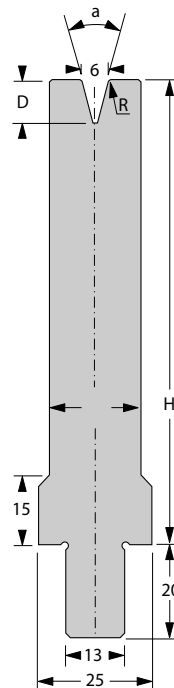

[R] Sugár (mm)*	0,75
[a] V – Szög	30°
[H] Magasság (mm)	100

[B] Szélesség (mm)	20
[D] Mélység (mm)	9,3

*egyéb sugarak igény szerint

Standard hosszúság	Cikkszám
50 mm	64208.0006.5016
55 mm	64208.0006.5017
60 mm	64208.0006.5018
65 mm	64208.0006.5019
70 mm	64208.0006.5020
75 mm	64208.0006.5021
80 mm	64208.0006.5022
85 mm	64208.0006.5023
90 mm	64208.0006.5024
95 mm	64208.0006.5025
100 mm	64208.0006.5026

Standard hosszúság	Cikkszám
200 mm	64208.0006.5027
275 mm	64208.0006.5028
300 mm	64208.0006.5029
515 mm	64208.0006.5030
1025 mm szek.	64208.0006.5031



F max 30° = 400 kN/m



18,0 kg/m



Szerszámbetét 13 mm



V8C/30° H55

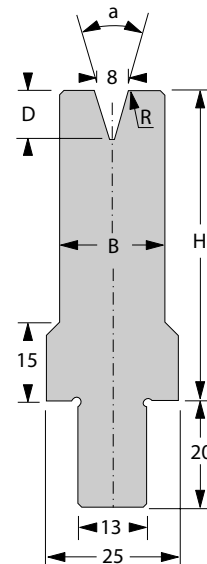
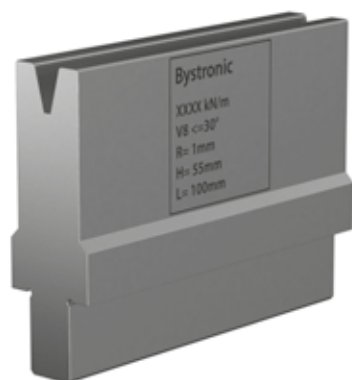

[R] Sugár (mm)*	1
[a] V – Szög	30°
[H] Magasság (mm)	55

[B] Szélesség (mm)	20
[D] Mélység (mm)	11,2

*egyéb sugarak igény szerint

Standard hosszúság	Cikkszám
50 mm	64208.0008.5001
55 mm	64208.0008.5002
60 mm	64208.0008.5003
65 mm	64208.0008.5004
70 mm	64208.0008.5005
75 mm	64208.0008.5006
80 mm	64208.0008.5007
85 mm	64208.0008.5008
90 mm	64208.0008.5009
95 mm	64208.0008.5010
100 mm	64208.0008.5011

Standard hosszúság	Cikkszám
200 mm	64208.0008.5012
275 mm	64208.0008.5013
300 mm	64208.0008.5014
515 mm	64208.0008.5015
1025 mm szek.	64208.0008.5000



F max 30° = 400 kN/m



10,8 kg/m



Szerszámvetét 13 mm



V8C/30° H100

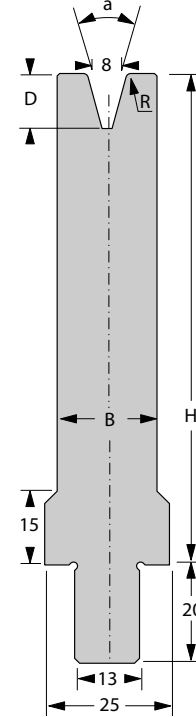

[R] Sugár (mm)*	1
[a] V – Szög	30°
[H] Magasság (mm)	100

[B] Szélesség (mm)	20
[D] Mélység (mm)	11,2

*egyéb sugarak igény szerint

Standard hosszúság	Cikkszám
50 mm	64208.0008.5016
55 mm	64208.0008.5017
60 mm	64208.0008.5018
65 mm	64208.0008.5019
70 mm	64208.0008.5020
75 mm	64208.0008.5021
80 mm	64208.0008.5022
85 mm	64208.0008.5023
90 mm	64208.0008.5024
95 mm	64208.0008.5025
100 mm	64208.0008.5026

Standard hosszúság	Cikkszám
200 mm	64208.0008.5027
275 mm	64208.0008.5028
300 mm	64208.0008.5029
515 mm	64208.0008.5030
1025 mm szek.	64208.0008.5165



F max 30° = 300 kN/m



17,8 kg/m



Szerszámbetét 13 mm



V10C/30° H55

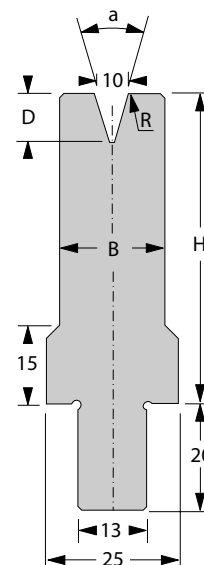
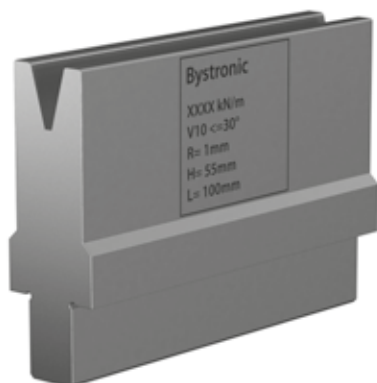

[R] Sugár (mm)*	1
[a] V – Szög	30°
[H] Magasság (mm)	55

[B] Szélesség (mm)	20
[D] Mélység (mm)	14,9

*egyéb sugarak igény szerint

Standard hosszúság	Cikkszám
50 mm	64208.0010.5001
55 mm	64208.0010.5002
60 mm	64208.0010.5003
65 mm	64208.0010.5004
70 mm	64208.0010.5005
75 mm	64208.0010.5006
80 mm	64208.0010.5007
85 mm	64208.0010.5008
90 mm	64208.0010.5009
95 mm	64208.0010.5010
100 mm	64208.0010.5011

Standard hosszúság	Cikkszám
200 mm	64208.0010.5012
275 mm	64208.0010.5013
300 mm	64208.0010.5014
515 mm	64208.0010.5015
1025 mm szek.	64208.0010.5000



F max 30° = 200 kN/m



10,6 kg/m



Szerszámbetét 13 mm



V10C/30° H100

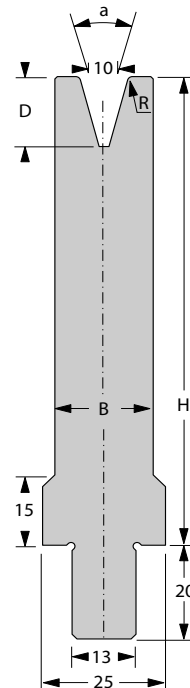

[R] Sugár (mm)*	1
[a] V – Szög	30°
[H] Magasság (mm)	100

[B] Szélesség (mm)	20
[D] Mélység (mm)	14,9

*egyéb sugarak igény szerint

Standard hosszúság	Cikkszám
50 mm	64208.0010.5016
55 mm	64208.0010.5017
60 mm	64208.0010.5018
65 mm	64208.0010.5019
70 mm	64208.0010.5020
75 mm	64208.0010.5021
80 mm	64208.0010.5022
85 mm	64208.0010.5023
90 mm	64208.0010.5024
95 mm	64208.0010.5025
100 mm	64208.0010.5026

Standard hosszúság	Cikkszám
200 mm	64208.0010.5027
275 mm	64208.0010.5028
300 mm	64208.0010.5029
515 mm	64208.0010.5030
1025 mm szek.	64208.0010.5031



F max 30° = 200 kN/m



17,6 kg/m



Szerszámbetét 13 mm



V12C/30° H55

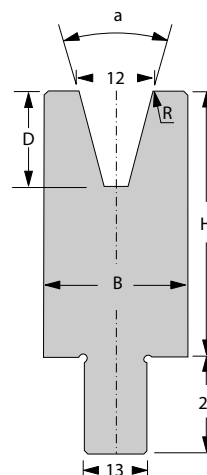

[R] Sugár (mm)*	1,5
[a] V – Szög	30°
[H] Magasság (mm)	55

[B] Szélesség (mm)	25
[D] Mélység (mm)	18,6

*egyéb sugarak igény szerint

Standard hosszúság	Cikkszám
50 mm	64208.0012.5001
55 mm	64208.0012.5002
60 mm	64208.0012.5003
65 mm	64208.0012.5004
70 mm	64208.0012.5005
75 mm	64208.0012.5006
80 mm	64208.0012.5007
85 mm	64208.0012.5008
90 mm	64208.0012.5009
95 mm	64208.0012.5010
100 mm	64208.0012.5011

Standard hosszúság	Cikkszám
200 mm	64208.0012.5012
275 mm	64208.0012.5013
300 mm	64208.0012.5014
515 mm	64208.0012.5015
1025 mm szek.	64208.0012.5000



F max 30° = 250 kN/m



11,8 kg/m



Szerszámbetét 13 mm



V12C/30° H100

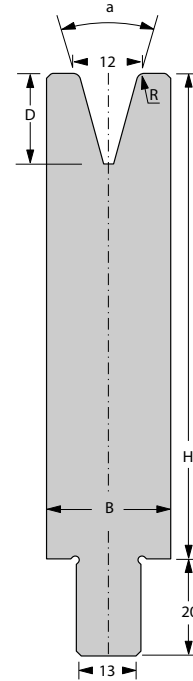

[R] Sugár (mm)*	1,5
[a] V – Szög	30°
[H] Magasság (mm)	100

[B] Szélesség (mm)	25
[D] Mélység (mm)	18,6

*egyéb sugarak igény szerint

Standard hosszúság	Cikkszám
50 mm	64208.0012.5017
55 mm	64208.0012.5018
60 mm	64208.0012.5019
65 mm	64208.0012.5020
70 mm	64208.0012.5021
75 mm	64208.0012.5022
80 mm	64208.0012.5023
85 mm	64208.0012.5024
90 mm	64208.0012.5025
95 mm	64208.0012.5026
100 mm	64208.0012.5027

Standard hosszúság	Cikkszám
200 mm	64208.0012.5028
275 mm	64208.0012.5029
300 mm	64208.0012.5016
515 mm	64208.0012.5031
1025 mm szek.	64208.0012.5030



$F_{max} 30^\circ = 250 \text{ kN/m}$



20,6 kg/m



Szerszámvetét 13 mm



V16C/30° H55

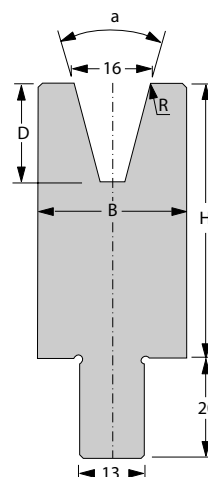

[R] Sugár (mm)*	2
[a] V – Szög	30°
[H] Magasság (mm)	55

[B] Szélesség (mm)	30
[D] Mélység (mm)	20,5

*egyéb sugarak igény szerint

Standard hosszúság	Cikkszám
50 mm	64208.0016.5001
55 mm	64208.0016.5002
60 mm	64208.0016.5003
65 mm	64208.0016.5004
70 mm	64208.0016.5005
75 mm	64208.0016.5006
80 mm	64208.0016.5007
85 mm	64208.0016.5008
90 mm	64208.0016.5009
95 mm	64208.0016.5010
100 mm	64208.0016.5011

Standard hosszúság	Cikkszám
200 mm	64208.0016.5012
275 mm	64208.0016.5013
300 mm	64208.0016.5014
515 mm	64208.0016.5015
1025 mm szek.	64208.0016.5000



F max 30° = 250 kN/m



13,3 kg/m



Szerszámbetét 13 mm



V16C/30° H100

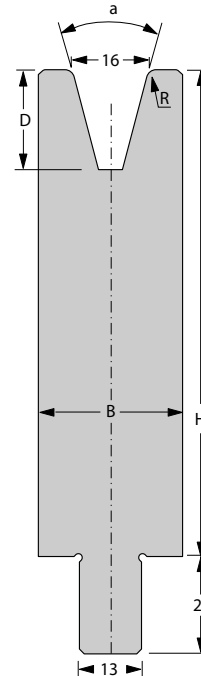

[R] Sugár (mm)*	2
[a] V – Szög	30°
[H] Magasság (mm)	100

[B] Szélesség (mm)	30
[D] Mélység (mm)	20,5

*egyéb sugarak igény szerint

Standard hosszúság	Cikkszám
50 mm	64208.0016.5016
55 mm	64208.0016.5017
60 mm	64208.0016.5018
65 mm	64208.0016.5019
70 mm	64208.0016.5020
75 mm	64208.0016.5021
80 mm	64208.0016.5022
85 mm	64208.0016.5023
90 mm	64208.0016.5024
95 mm	64208.0016.5025
100 mm	64208.0016.5026

Standard hosszúság	Cikkszám
200 mm	64208.0016.5027
275 mm	64208.0016.5028
300 mm	64208.0016.5029
515 mm	64208.0016.5030
1025 mm szek.	64208.0016.5040



F max 30° = 250 kN/m



23,9 kg/m



Szerszámbetét 13 mm



V20C/30° H55

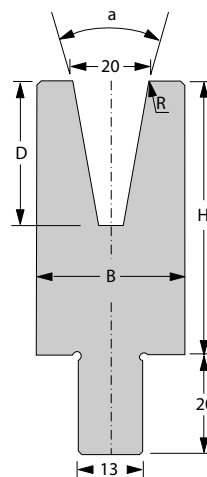

[R] Sugár (mm)*	2,5
[a] V – Szög	30°
[H] Magasság (mm)	55

[B] Szélesség (mm)	30
[D] Mélység (mm)	28

*egyéb sugarak igény szerint

Standard hosszúság	Cikkszám
50 mm	64208.0020.5001
55 mm	64208.0020.5002
60 mm	64208.0020.5003
65 mm	64208.0020.5004
70 mm	64208.0020.5005
75 mm	64208.0020.5006
80 mm	64208.0020.5007
85 mm	64208.0020.5008
90 mm	64208.0020.5009
95 mm	64208.0020.5010
100 mm	64208.0020.5011

Standard hosszúság	Cikkszám
200 mm	64208.0020.5012
275 mm	64208.0020.5013
300 mm	64208.0020.5014
515 mm	64208.0020.5015
1025 mm szek.	64208.0020.5000



F max 30° = 150 kN/m



12,2 kg/m



Szerszámbetét 13 mm



V20C/30° H100

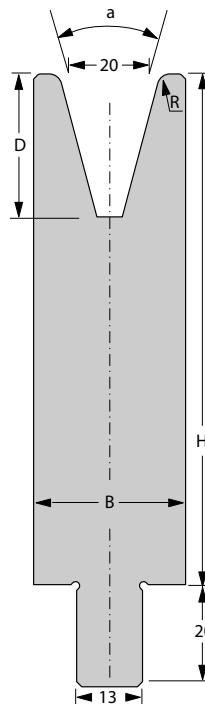

[R] Sugár (mm)*	2,5
[a] V – Szög	30°
[H] Magasság (mm)	100

[B] Szélesség (mm)	30
[D] Mélység (mm)	28

*egyéb sugarak igény szerint

Standard hosszúság	Cikkszám
50 mm	64208.0020.5017
55 mm	64208.0020.5018
60 mm	64208.0020.5019
65 mm	64208.0020.5020
70 mm	64208.0020.5021
75 mm	64208.0020.5022
80 mm	64208.0020.5023
85 mm	64208.0020.5024
90 mm	64208.0020.5025
95 mm	64208.0020.5026
100 mm	64208.0020.5027

Standard hosszúság	Cikkszám
200 mm	64208.0020.5028
275 mm	64208.0020.5029
300 mm	64208.0020.5016
515 mm	64208.0020.5031
1025 mm szek.	64208.0020.5030



F max 30° = 150 kN/m



22,8 kg/m



Szerszámbetét 13 mm



V24C/30° H55

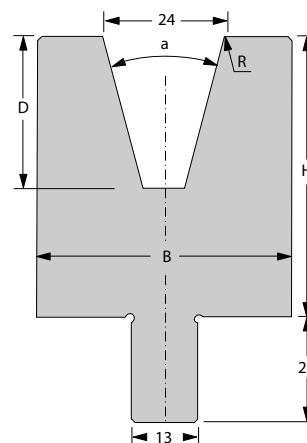

[R] Sugár (mm)*	3
[a] V – Szög	30°
[H] Magasság (mm)	55

[B] Szélesség (mm)	40
[D] Mélység (mm)	29,8

*egyéb sugarak igény szerint

Standard hosszúság	Cikkszám
50 mm	64208.0024.5001
55 mm	64208.0024.5002
60 mm	64208.0024.5003
65 mm	64208.0024.5004
70 mm	64208.0024.5005
75 mm	64208.0024.5006
80 mm	64208.0024.5007
85 mm	64208.0024.5008
90 mm	64208.0024.5009
95 mm	64208.0024.5010
100 mm	64208.0024.5011

Standard hosszúság	Cikkszám
200 mm	64208.0024.5012
275 mm	64208.0024.5013
300 mm	64208.0024.5014
515 mm	64208.0024.5015
1025 mm szek.	64208.0024.5000



F max 30° = 300 kN/m



15,5 kg/m



Szerszámbetét 13 mm



V24C/30° H100

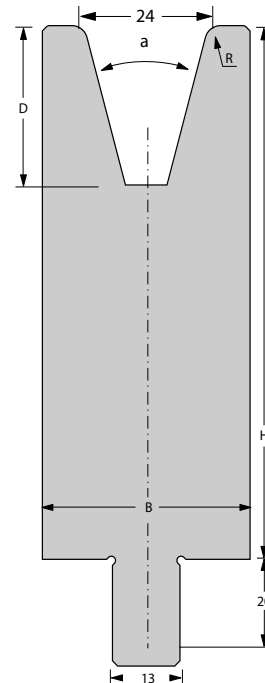

[R] Sugár (mm)*	3
[a] V – Szög	30°
[H] Magasság (mm)	100

[B] Szélesség (mm)	40
[D] Mélység (mm)	29,8

*egyéb sugarak igény szerint

Standard hosszúság	Cikkszám
50 mm	64208.0024.5016
55 mm	64208.0024.5017
60 mm	64208.0024.5018
65 mm	64208.0024.5019
70 mm	64208.0024.5020
75 mm	64208.0024.5021
80 mm	64208.0024.5022
85 mm	64208.0024.5023
90 mm	64208.0024.5024
95 mm	64208.0024.5025
100 mm	64208.0024.5026

Standard hosszúság	Cikkszám
200 mm	64208.0024.5027
275 mm	64208.0024.5028
300 mm	64208.0024.5029
515 mm	64208.0024.5030
1025 mm szek.	64208.0024.5031



$F_{max} 30^\circ = 300 \text{ kN/m}$



29,6 kg/m



Szerszámbetét 13 mm



V32C/30° H55

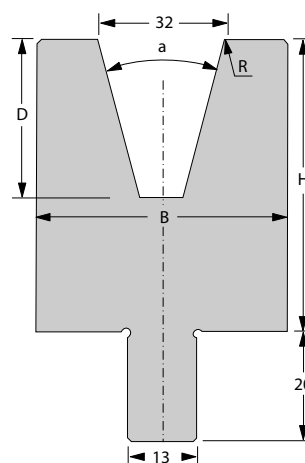
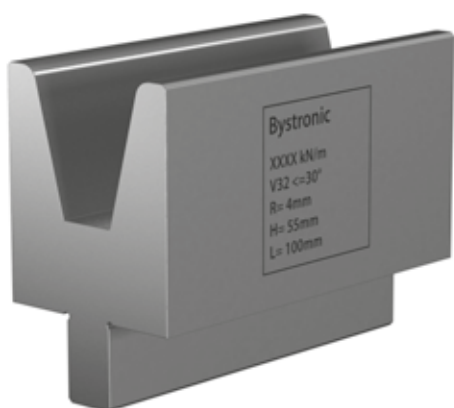

[R] Sugár (mm)*	4
[a] V - Szög	30°
[H] Magasság (mm)	55

[B] Szélesség (mm)	48
[D] Mélység (mm)	33,6

*egyéb sugarak igény szerint

Standard hosszúság	Cikkszám
50 mm	64208.0032.5001
55 mm	64208.0032.5002
60 mm	64208.0032.5003
65 mm	64208.0032.5004
70 mm	64208.0032.5005
75 mm	64208.0032.5006
80 mm	64208.0032.5007
85 mm	64208.0032.5008
90 mm	64208.0032.5009
95 mm	64208.0032.5010
100 mm	64208.0032.5011

Standard hosszúság	Cikkszám
200 mm	64208.0032.5012
275 mm	64208.0032.5013
300 mm	64208.0032.5014
515 mm	64208.0032.5015
1025 mm szek.	64208.0032.5000



F max 30° = 300 kN/m



16,7 kg/m



Szerszámbetét 13 mm



V32C/30° H100

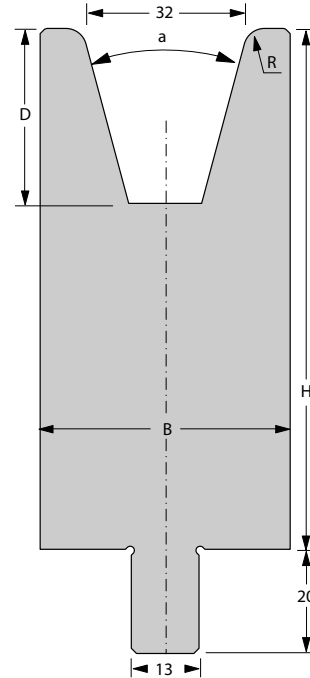

[R] Sugár (mm)*	4
[a] V – Szög	30°
[H] Magasság (mm)	100

[B] Szélesség (mm)	48
[D] Mélység (mm)	33,6

*egyéb sugarak igény szerint

Standard hosszúság	Cikkszám
50 mm	64208.0032.5017
55 mm	64208.0032.5018
60 mm	64208.0032.5019
65 mm	64208.0032.5020
70 mm	64208.0032.5021
75 mm	64208.0032.5022
80 mm	64208.0032.5023
85 mm	64208.0032.5024
90 mm	64208.0032.5025
95 mm	64208.0032.5026
100 mm	64208.0032.5027

Standard hosszúság	Cikkszám
200 mm	64208.0032.5028
275 mm	64208.0032.5029
300 mm	64208.0032.5016
515 mm	64208.0032.5031
1025 mm szek.	64208.0032.5030



$F_{max} 30^\circ = 300 \text{ kN/m}$



33,7 kg/m



Szerszámbetét 13 mm



V40C/60° H55

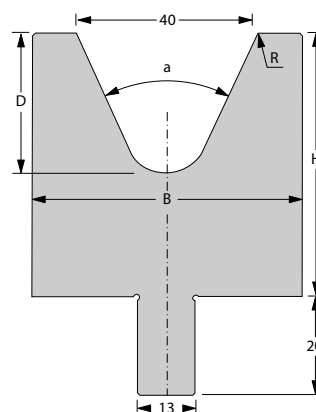
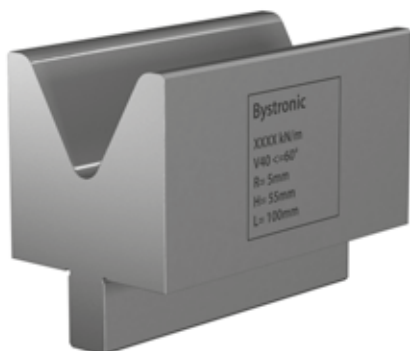

[R] Sugár (mm)*	5
[a] V – Szög	60°
[H] Magasság (mm)	55

[B] Szélesség (mm)	55
[D] Mélység (mm)	29,6

*egyéb sugarak igény szerint

Standard hosszúság	Cikkszám
50 mm	64208.0040.5001
55 mm	64208.0040.5002
60 mm	64208.0040.5003
65 mm	64208.0040.5004
70 mm	64208.0040.5005
75 mm	64208.0040.5006
80 mm	64208.0040.5007
85 mm	64208.0040.5008
90 mm	64208.0040.5009
95 mm	64208.0040.5010
100 mm	64208.0040.5011

Standard hosszúság	Cikkszám
200 mm	64208.0040.5012
275 mm	64208.0040.5013
300 mm	64208.0040.5014
515 mm	64208.0040.5015
1025 mm szek.	64208.0040.5000



F max 60° = 1800 kN/m



20,5 kg/m



Szerszámbetét 13 mm



V40C/60° H100

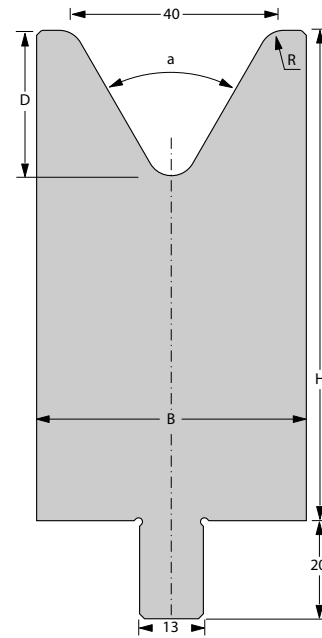

[R] Sugár (mm)*	5
[a] V – Szög	60°
[H] Magasság (mm)	100

[B] Szélesség (mm)	55
[D] Mélység (mm)	29,6

*egyéb sugarak igény szerint

Standard hosszúság	Cikkszám
50 mm	64208.0040.5017
55 mm	64208.0040.5018
60 mm	64208.0040.5019
65 mm	64208.0040.5020
70 mm	64208.0040.5021
75 mm	64208.0040.5022
80 mm	64208.0040.5023
85 mm	64208.0040.5024
90 mm	64208.0040.5025
95 mm	64208.0040.5026
100 mm	64208.0040.5027

Standard hosszúság	Cikkszám
200 mm	64208.0040.5028
275 mm	64208.0040.5029
300 mm	64208.0040.5016
515 mm	64208.0040.5031
1025 mm szek.	64208.0040.5030



$F_{max} 60^\circ = 1300 \text{ kN/m}$



39,9 kg/m



Szerszámbetét 13 mm



V50C/60° H55

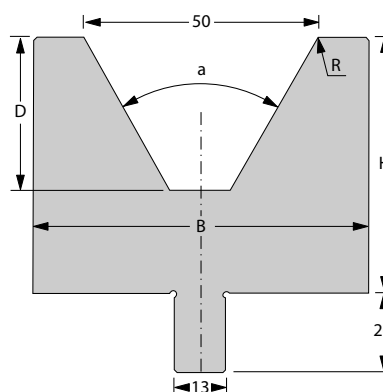
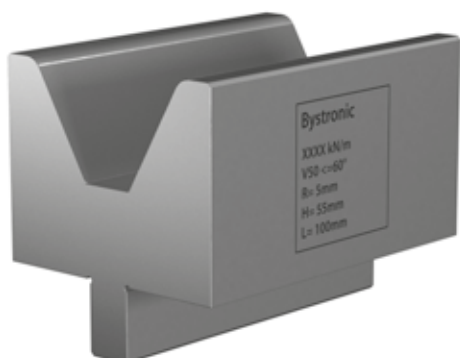

[R] Sugár (mm)*	5
[a] V – Szög	60°
[H] Magasság (mm)	55

[B] Szélesség (mm)	70
[D] Mélység (mm)	30,3

*egyéb sugarak igény szerint

Standard hosszúság	Cikkszám
50 mm	64208.0050.5001
55 mm	64208.0050.5002
60 mm	64208.0050.5003
65 mm	64208.0050.5004
70 mm	64208.0050.5005
75 mm	64208.0050.5006
80 mm	64208.0050.5007
85 mm	64208.0050.5008
90 mm	64208.0050.5009
95 mm	64208.0050.5010
100 mm	64208.0050.5011

Standard hosszúság	Cikkszám
200 mm	64208.0050.5012
275 mm	64208.0050.5013
300 mm	64208.0050.5014
515 mm	64208.0050.5015
1025 mm szek.	64208.0050.5000



F max 60° = 1200 kN/m



24,5 kg/m



Szerszámbetét 13 mm



V50C/60° H100

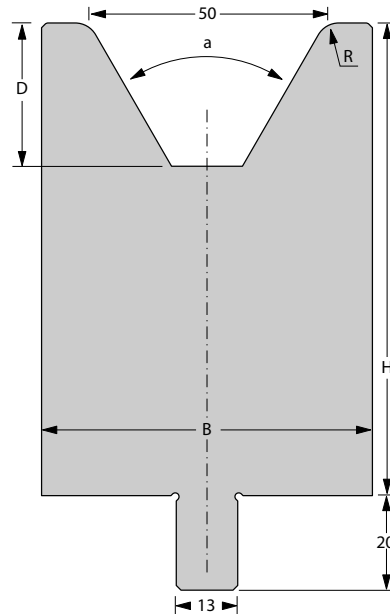

[R] Sugár (mm)*	5
[a] V – Szög	60°
[H] Magasság (mm)	100

[B] Szélesség (mm)	70
[D] Mélység (mm)	30,3

*egyéb sugarak igény szerint

Standard hosszúság	Cikkszám
50 mm	64208.0050.5016
55 mm	64208.0050.5017
60 mm	64208.0050.5018
65 mm	64208.0050.5019
70 mm	64208.0050.5020
75 mm	64208.0050.5021
80 mm	64208.0050.5022
85 mm	64208.0050.5023
90 mm	64208.0050.5024
95 mm	64208.0050.5025
100 mm	64208.0050.5026

Standard hosszúság	Cikkszám
200 mm	64208.0050.5027
275 mm	64208.0050.5028
300 mm	64208.0050.5029
515 mm	64208.0050.5031
1025 mm szek.	64208.0050.5030



$F_{max} 60^\circ = 2000 \text{ kN/m}$



49,2 kg/m



Szerszámbetét 13 mm



V60C/60° H65

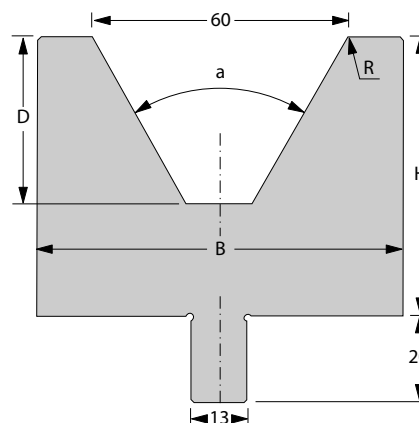
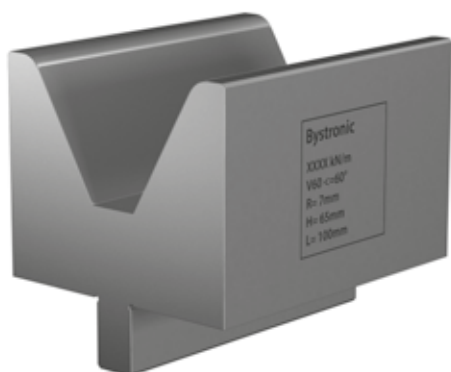

[R] Sugár (mm)*	7
[a] V – Szög	60°
[H] Magasság (mm)	65

[B] Szélesség (mm)	80
[D] Mélység (mm)	39

*egyéb sugarak igény szerint

Standard hosszúság	Cikkszám
50 mm	64208.0060.5001
55 mm	64208.0060.5002
60 mm	64208.0060.5003
65 mm	64208.0060.5004
70 mm	64208.0060.5005
75 mm	64208.0060.5006
80 mm	64208.0060.5007
85 mm	64208.0060.5008
90 mm	64208.0060.5009
95 mm	64208.0060.5010
100 mm	64208.0060.5011

Standard hosszúság	Cikkszám
200 mm	64208.0060.5012
275 mm	64208.0060.5013
300 mm	64208.0060.5014
515 mm	64208.0060.5031
1025 mm szek.	64208.0060.5000



F max 60° = 1600 kN/m



31,4 kg/m



Szerszámbetét 13 mm



V60C/60° H100

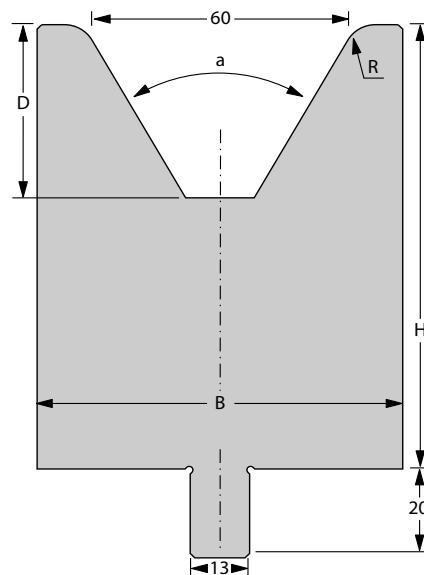

[R] Sugár (mm)*	7
[a] V – Szög	60°
[H] Magasság (mm)	100

[B] Szélesség (mm)	80
[D] Mélység (mm)	39

*egyéb sugarak igény szerint

Standard hosszúság	Cikkszám
50 mm	64208.0060.5016
55 mm	64208.0060.5017
60 mm	64208.0060.5018
65 mm	64208.0060.5019
70 mm	64208.0060.5020
75 mm	64208.0060.5021
80 mm	64208.0060.5022
85 mm	64208.0060.5023
90 mm	64208.0060.5024
95 mm	64208.0060.5025
100 mm	64208.0060.5026

Standard hosszúság	Cikkszám
200 mm	64208.0060.5015
275 mm	64208.0060.5027
300 mm	64208.0060.5028
1025 mm szek.	64208.0060.5030



F max 60° = 2000 kN/m



53,4 kg/m



Szerszámbetét 13 mm



V80C/80° H65

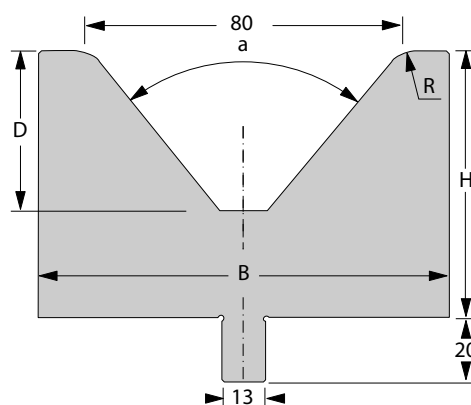
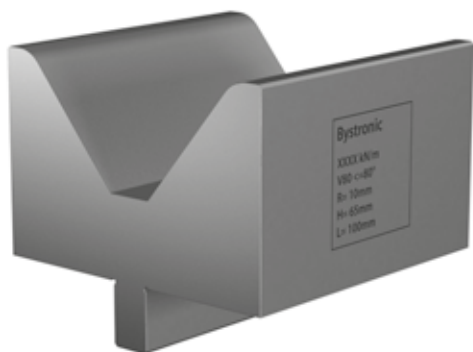

[R] Sugár (mm)*	10
[a] V – Szög	80°
[H] Magasság (mm)	65

[B] Szélesség (mm)	100
[D] Mélység (mm)	38,7

*egyéb sugarak igény szerint

Standard hosszúság	Cikkszám
50 mm	64208.0080.5001
55 mm	64208.0080.5002
60 mm	64208.0080.5003
65 mm	64208.0080.5004
70 mm	64208.0080.5005
75 mm	64208.0080.5006
80 mm	64208.0080.5007
85 mm	64208.0080.5008
90 mm	64208.0080.5009
95 mm	64208.0080.5010
100 mm	64208.0080.5011

Standard hosszúság	Cikkszám
200 mm	64208.0080.5012
275 mm	64208.0080.5013
300 mm	64208.0080.5014
515 mm	64208.0080.5029
1025 mm szek.	64208.0080.5000



F max 80° = 1400 kN/m



38,6 kg/m



Szerszámbetét 13 mm



V80C/80° H100

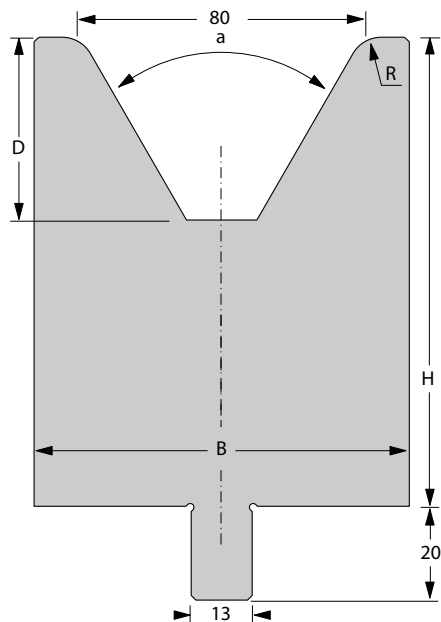

[R] Sugár (mm)*	10
[a] V – Szög	80°
[H] Magasság (mm)	100

[B] Szélesség (mm)	100
[D] Mélység (mm)	38,7

*egyéb sugarak igény szerint

Standard hosszúság	Cikkszám
50 mm	64208.0080.5015
55 mm	64208.0080.5016
60 mm	64208.0080.5017
65 mm	64208.0080.5018
70 mm	64208.0080.5019
75 mm	64208.0080.5020
80 mm	64208.0080.5021
85 mm	64208.0080.5022
90 mm	64208.0080.5023
95 mm	64208.0080.5024
100 mm	64208.0080.5025

Standard hosszúság	Cikkszám
200 mm	64208.0080.5026
275 mm	64208.0080.5027
300 mm	64208.0080.5028
1025 mm szek.	64208.0080.5030



F max 80° = 1400 kN/m



66,0 kg/m



Szerszámbetét 13 mm



V100C/80° H85

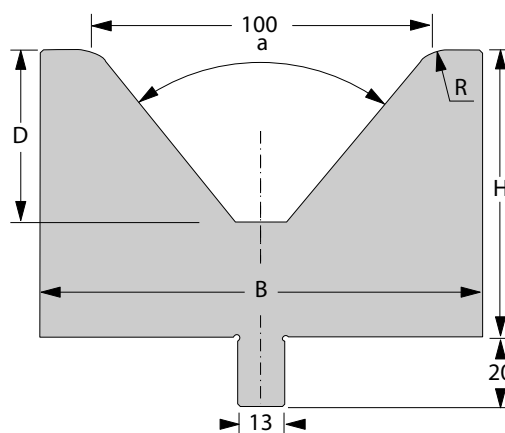
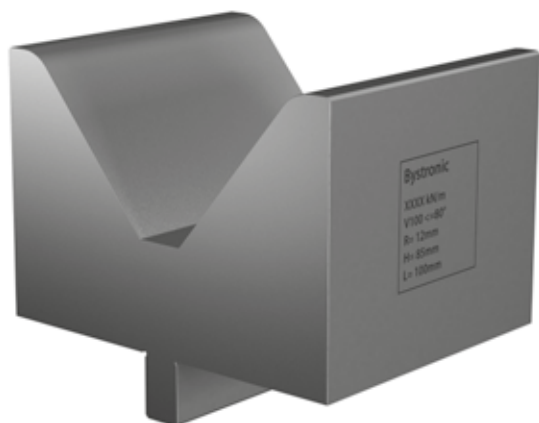

[R] Sugár (mm)*	12
[a] V – Szög	80°
[H] Magasság (mm)	85

[B] Szélesség (mm)	125
[D] Mélység (mm)	50,5

*egyéb sugarak igény szerint

Standard hosszúság	Cikkszám
50 mm	64208.0100.5001
55 mm	64208.0100.5002
60 mm	64208.0100.5003
65 mm	64208.0100.5004
70 mm	64208.0100.5005
75 mm	64208.0100.5006
80 mm	64208.0100.5007
85 mm	64208.0100.5008
90 mm	64208.0100.5009
95 mm	64208.0100.5010
100 mm	64208.0100.5011

Standard hosszúság	Cikkszám
200 mm	64208.0100.5012
275 mm	64208.0100.5013
300 mm	64208.0100.5014
1025 mm szek.	64208.0100.5000



F max 80° = 1800 kN/m



60,5 kg/m



Szerszámbetét 13 mm



V120C/80° H105

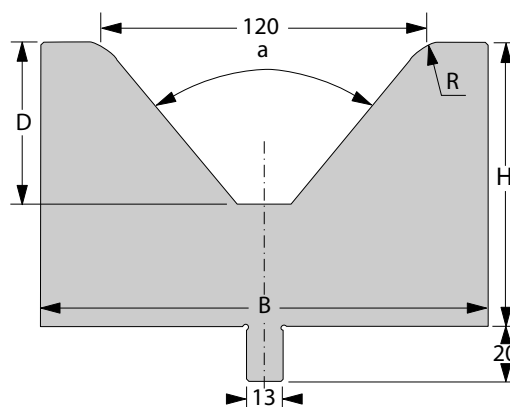
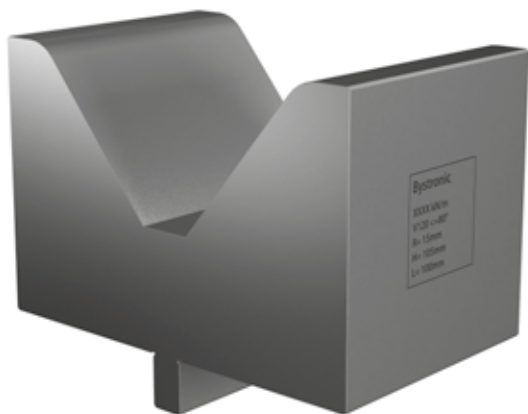

[R] Sugár (mm)*	15
[a] V – Szög	80°
[H] Magasság (mm)	105

[B] Szélesség (mm)	160
[D] Mélység (mm)	59,5

*egyéb sugarak igény szerint

Standard hosszúság	Cikkszám
50 mm	64208.0120.5001
55 mm	64208.0120.5002
60 mm	64208.0120.5003
65 mm	64208.0120.5004
70 mm	64208.0120.5005
75 mm	64208.0120.5006
80 mm	64208.0120.5007
85 mm	64208.0120.5008
90 mm	64208.0120.5009
95 mm	64208.0120.5010
100 mm	64208.0120.5011

Standard hosszúság	Cikkszám
200 mm	64208.0120.5012
275 mm	64208.0120.5013
300 mm	64208.0120.5014
1025 mm szek.	64208.0120.5000



F max 80° = 2000 kN/m



101,0 kg/m



Szerszámbetét 13 mm



V6SC/30° H55

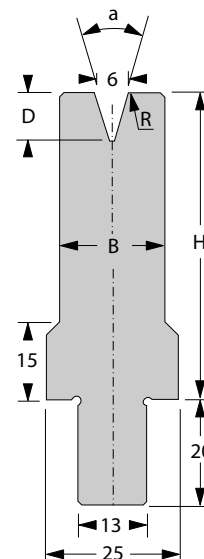

[R] Sugár (mm)*	0,75
[a] V – Szög	30°
[H] Magasság (mm)	55

[B] Szélesség (mm)	12
[D] Mélység (mm)	9,3

*egyéb sugarak igény szerint

Standard hosszúság	Cikkszám
50 mm	64208.0006.5101
55 mm	64208.0006.5102
60 mm	64208.0006.5103
65 mm	64208.0006.5104
70 mm	64208.0006.5105
75 mm	64208.0006.5106
80 mm	64208.0006.5107
85 mm	64208.0006.5108
90 mm	64208.0006.5109
95 mm	64208.0006.5110
100 mm	64208.0006.5111

Standard hosszúság	Cikkszám
200 mm	64208.0006.5112
275 mm	64208.0006.5113
300 mm	64208.0006.5114
515 mm	64208.0006.5115
1025 mm szek.	64208.0006.5100



F max 30° = 100 kN/m



8,1 kg/m



Szerszámbetét 13 mm



V6SC/30° H100

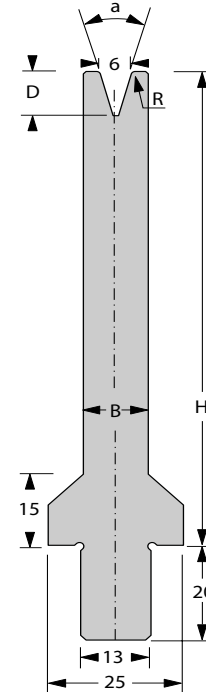

[R] Sugár (mm)*	0,75
[a] V – Szög	30°
[H] Magasság (mm)	100

[B] Szélesség (mm)	12
[D] Mélység (mm)	9,3

*egyéb sugarak igény szerint

Standard hosszúság	Cikkszám
50 mm	64208.0006.5151
55 mm	64208.0006.5152
60 mm	64208.0006.5153
65 mm	64208.0006.5154
70 mm	64208.0006.5155
75 mm	64208.0006.5156
80 mm	64208.0006.5157
85 mm	64208.0006.5158
90 mm	64208.0006.5159
95 mm	64208.0006.5160
100 mm	64208.0006.5161

Standard hosszúság	Cikkszám
200 mm	64208.0006.5162
275 mm	64208.0006.5163
300 mm	64208.0006.5164
515 mm	64208.0006.5165
1025 mm szek.	64208.0006.5150



F max 30° = 100 kN/m



12,3 kg/m



Szerszámbetét 13 mm



V8SC/30° H55

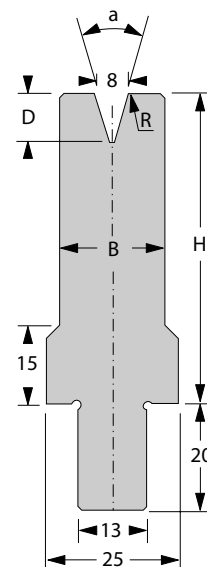

[R] Sugár (mm)*	1
[a] V – Szög	30°
[H] Magasság (mm)	55

[B] Szélesség (mm)	14
[D] Mélység (mm)	11,2

*egyéb sugarak igény szerint

Standard hosszúság	Cikkszám
50 mm	64208.0008.5102
55 mm	64208.0008.5103
60 mm	64208.0008.5104
65 mm	64208.0008.5105
70 mm	64208.0008.5106
75 mm	64208.0008.5107
80 mm	64208.0008.5108
85 mm	64208.0008.5109
90 mm	64208.0008.5110
95 mm	64208.0008.5111
100 mm	64208.0008.5112

Standard hosszúság	Cikkszám
200 mm	64208.0008.5113
275 mm	64208.0008.5114
300 mm	64208.0008.5115
515 mm	64208.0008.5116
1025 mm szek.	64208.0008.5100



F max 30° = 100 kN/m



8,7 kg/m



Szerszámbetét 13 mm



V8SC/30° H100

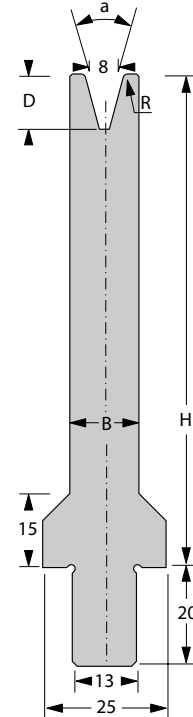

[R] Sugár (mm)*	1
[a] V – Szög	30°
[H] Magasság (mm)	100

[B] Szélesség (mm)	14
[D] Mélység (mm)	11,2

*egyéb sugarak igény szerint

Standard hosszúság	Cikkszám
50 mm	64208.0008.5151
55 mm	64208.0008.5152
60 mm	64208.0008.5153
65 mm	64208.0008.5154
70 mm	64208.0008.5155
75 mm	64208.0008.5156
80 mm	64208.0008.5157
85 mm	64208.0008.5158
90 mm	64208.0008.5159
95 mm	64208.0008.5160
100 mm	64208.0008.5161

Standard hosszúság	Cikkszám
200 mm	64208.0008.5162
275 mm	64208.0008.5163
300 mm	64208.0008.5164
515 mm	64208.0008.5166
1025 mm szek.	64208.0008.5150



$F_{max} 30^\circ = 1000 \text{ kN/m}$



13,7 kg/m



Szerszámbetét 13 mm



V10SC/30° H55

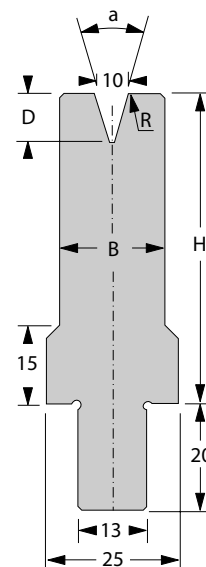

[R] Sugár (mm)*	1
[a] V – Szög	30°
[H] Magasság (mm)	55

[B] Szélesség (mm)	16
[D] Mélység (mm)	14,9

*egyéb sugarak igény szerint

Standard hosszúság	Cikkszám
50 mm	64208.0010.5101
55 mm	64208.0010.5102
60 mm	64208.0010.5103
65 mm	64208.0010.5104
70 mm	64208.0010.5105
75 mm	64208.0010.5106
80 mm	64208.0010.5107
85 mm	64208.0010.5108
90 mm	64208.0010.5109
95 mm	64208.0010.5110
100 mm	64208.0010.5111

Standard hosszúság	Cikkszám
200 mm	64208.0010.5112
275 mm	64208.0010.5113
300 mm	64208.0010.5114
515 mm	64208.0010.5115
1025 mm szek.	64208.0010.5100



F max 30° = 100 kN/m



9,1 kg/m



Szerszámbetét 13 mm



V10SC/30° H100

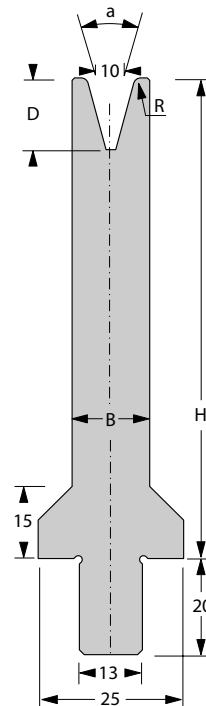

[R] Sugár (mm)*	1
[a] V – Szög	30°
[H] Magasság (mm)	100

[B] Szélesség (mm)	16
[D] Mélység (mm)	14,9

*egyéb sugarak igény szerint

Standard hosszúság	Cikkszám
50 mm	64208.0010.5117
55 mm	64208.0010.5118
60 mm	64208.0010.5119
65 mm	64208.0010.5120
70 mm	64208.0010.5121
75 mm	64208.0010.5122
80 mm	64208.0010.5123
85 mm	64208.0010.5124
90 mm	64208.0010.5125
95 mm	64208.0010.5126
100 mm	64208.0010.5127

Standard hosszúság	Cikkszám
200 mm	64208.0010.5128
275 mm	64208.0010.5129
300 mm	64208.0010.5130
515 mm	64208.0010.5131
1025 mm szek.	64208.0010.5116



F max 30° = 100 kN/m



14,7 kg/m



Szerszámbetét 13 mm



V12SC/30° H55

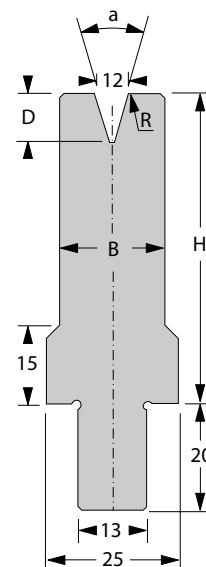
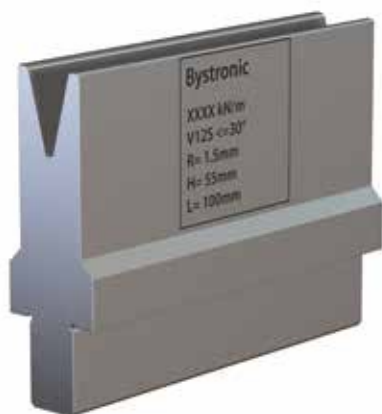

[R] Sugár (mm)*	1,5
[a] V – Szög	30°
[H] Magasság (mm)	55

[B] Szélesség (mm)	18
[D] Mélység (mm)	18,6

*egyéb sugarak igény szerint

Standard hosszúság	Cikkszám
50 mm	64208.0012.5101
55 mm	64208.0012.5102
60 mm	64208.0012.5103
65 mm	64208.0012.5104
70 mm	64208.0012.5105
75 mm	64208.0012.5106
80 mm	64208.0012.5107
85 mm	64208.0012.5108
90 mm	64208.0012.5109
95 mm	64208.0012.5110
100 mm	64208.0012.5111

Standard hosszúság	Cikkszám
200 mm	64208.0012.5112
275 mm	64208.0012.5113
300 mm	64208.0012.5114
515 mm	64208.0012.5115
1025 mm szek.	64208.0012.5100



F max 30° = 100 kN/m



9,5 kg/m



Szerszámbetét 13 mm



V12SC/30° H100

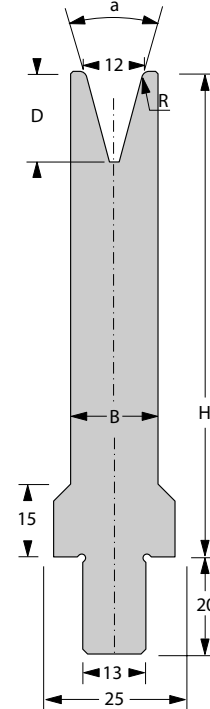

[R] Sugár (mm)*	1,5
[a] V – Szög	30°
[H] Magasság (mm)	100

[B] Szélesség (mm)	18
[D] Mélység (mm)	18,6

*egyéb sugarak igény szerint

Standard hosszúság	Cikkszám
50 mm	64208.0012.5117
55 mm	64208.0012.5118
60 mm	64208.0012.5119
65 mm	64208.0012.5120
70 mm	64208.0012.5121
75 mm	64208.0012.5122
80 mm	64208.0012.5123
85 mm	64208.0012.5124
90 mm	64208.0012.5125
95 mm	64208.0012.5126
100 mm	64208.0012.5127

Standard hosszúság	Cikkszám
200 mm	64208.0012.5128
275 mm	64208.0012.5129
300 mm	64208.0012.5130
515 mm	64208.0012.5131
1025 mm szek.	64208.0012.5116



F max 30° = 100 kN/m



15,9 kg/m



Szerszámbetét 13 mm



Hemming szerszámok

Lapító szerszámok

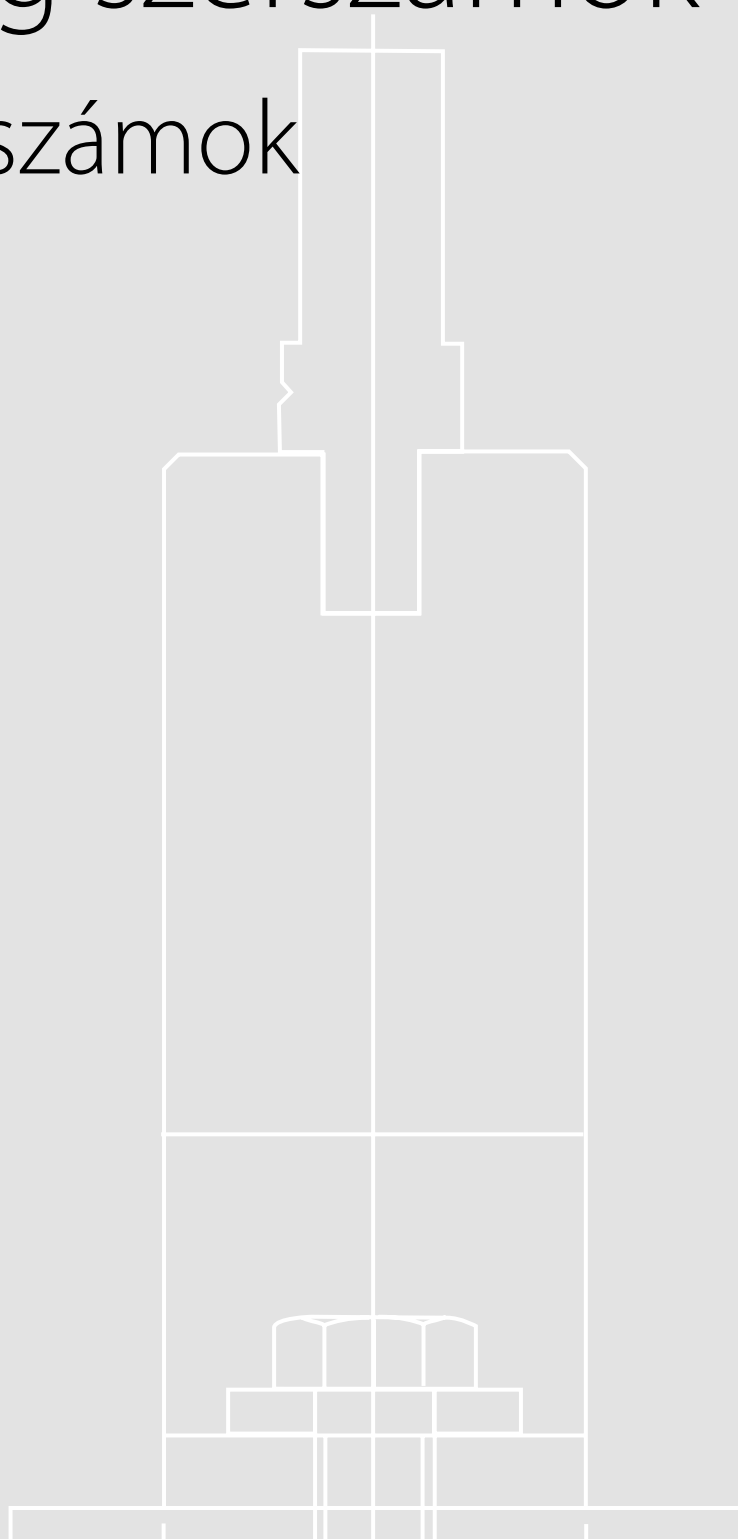





P11 RF-AC H250

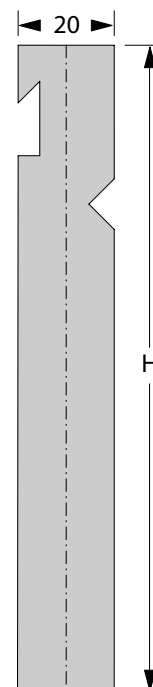

[B] Szélesség (mm)	20
[H] Magasság (mm)	250

Standard hosszúság	Cikkszám
30 mm	65208.0011.5001
35 mm	65208.0011.5002
40 mm	65208.0011.5003
45 mm	65208.0011.5004
50 mm	65208.0011.5005
55 mm	65208.0011.5006
60 mm	65208.0011.5007
65 mm	65208.0011.5008
70 mm	65208.0011.5009
75 mm	65208.0011.5010
80 mm	65208.0011.5011

Standard hosszúság	Cikkszám
85 mm	65208.0011.5012
90 mm	65208.0011.5013
95 mm	65208.0011.5014
100 mm	65208.0011.5015
200 mm	65208.0011.5016
275 mm	65208.0011.5017
300 mm	65208.0011.5018
515 mm	65208.0011.5023
1175 mm szek.	65208.0011.5000

F_{max} = 1400 kN/m

35,9 kg/m



98,0 mm



P900/8 RF-AC/30° H250

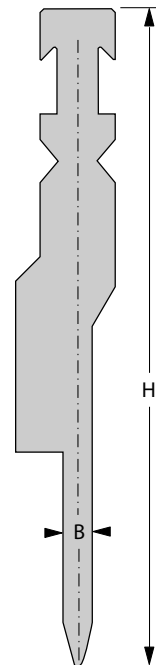

[B] Szélesség (mm)	26,5
[H] Magasság (mm)	250

Standard hosszúság	Cikkszám
30 mm	65208.0900.5002
35 mm	65208.0900.5003
40 mm	65208.0900.5004
45 mm	65208.0900.5005
50 mm	65208.0900.5006
55 mm	65208.0900.5007
60 mm	65208.0900.5008
65 mm	65208.0900.5009
70 mm	65208.0900.5010
75 mm	65208.0900.5011
80 mm	65208.0900.5012

Standard hosszúság	Cikkszám
85 mm	65208.0900.5013
90 mm	65208.0900.5014
95 mm	65208.0900.5015
100 mm	65208.0900.5016
200 mm	65208.0900.5017
275 mm	65208.0900.5018
300 mm	65208.0900.5019
515 mm	65208.0900.5020
1175 mm szek.	65208.0900.5000



F max = 1000 kN/m



29,2 kg/m



P900/10 RF-AC/30° H250

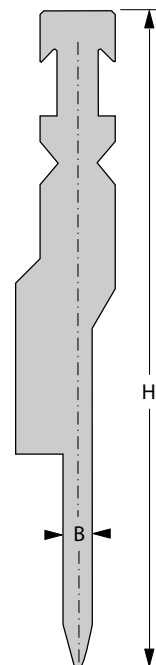

[B] Szélesség (mm)	26,5
[H] Magasság (mm)	250

Standard hosszúság	Cikkszám
30 mm	65208.0900.5050
35 mm	65208.0900.5041
40 mm	65208.0900.5042
45 mm	65208.0900.5043
50 mm	65208.0900.5044
55 mm	65208.0900.5045
60 mm	65208.0900.5046
65 mm	65208.0900.5047
70 mm	65208.0900.5048
75 mm	65208.0900.5049
80 mm	65208.0900.5040

Standard hosszúság	Cikkszám
85 mm	65208.0900.5051
90 mm	65208.0900.5052
95 mm	65208.0900.5053
100 mm	65208.0900.5054
200 mm	65208.0900.5055
275 mm	65208.0900.5056
300 mm	65208.0900.5057
515 mm	65208.0900.5058
1175 mm szek.	65208.0900.5059

F_{max} = 1000 kN/m

29,2 kg/m



P900/12 RF-AC/30° H250

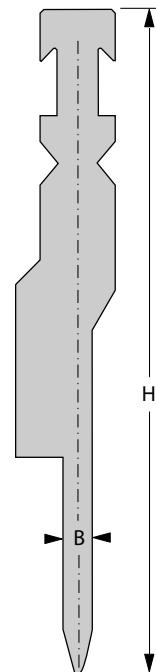

[B] Szélesség (mm)	26,5
[H] Magasság (mm)	250

Standard hosszúság	Cikkszám
30 mm	65208.0900.5021
35 mm	65208.0900.5022
40 mm	65208.0900.5023
45 mm	65208.0900.5024
50 mm	65208.0900.5025
55 mm	65208.0900.5026
60 mm	65208.0900.5027
65 mm	65208.0900.5028
70 mm	65208.0900.5029
75 mm	65208.0900.5030
80 mm	65208.0900.5031

Standard hosszúság	Cikkszám
85 mm	65208.0900.5032
90 mm	65208.0900.5033
95 mm	65208.0900.5034
100 mm	65208.0900.5035
200 mm	65208.0900.5036
275 mm	65208.0900.5037
300 mm	65208.0900.5001
515 mm	65208.0900.5038
1175 mm szek.	65208.0900.5039



F max = 1000 kN/m



34,3 kg/m



V-Flat B40

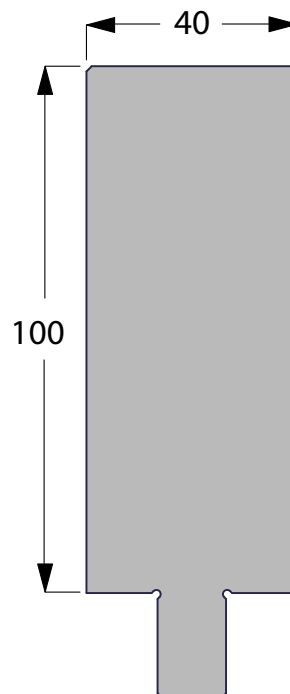

[B] Szélesség (mm) 40

[H] Magasság (mm) 100

Standard hosszúság	Cikkszám
50 mm	64208.0000.5001
55 mm	64208.0000.5002
60 mm	64208.0000.5003
65 mm	64208.0000.5004
70 mm	64208.0000.5005
75 mm	64208.0000.5006
80 mm	64208.0000.5007
85 mm	64208.0000.5008
90 mm	64208.0000.5009
95 mm	64208.0000.5010
100 mm	64208.0000.5011

Standard hosszúság	Cikkszám
200 mm	64208.0000.5012
275 mm	64208.0000.5013
300 mm	64208.0000.5014
515 mm	64208.0000.5015
1025 mm szek.	64208.0000.5000



F max 30° = 2000 kN/m



35,5 kg/m



Szerszámbetét 13 mm



V900/08C

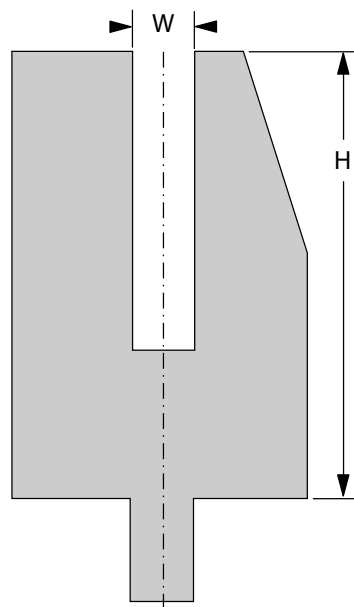

[B] Szélesség (mm)	55
[H] Magasság (mm)	85

Standard hosszúság	Cikkszám
50 mm	64208.0900.5003
55 mm	64208.0900.5004
60 mm	64208.0900.5005
65 mm	64208.0900.5006
70 mm	64208.0900.5007
75 mm	64208.0900.5008
80 mm	64208.0900.5009
85 mm	64208.0900.5010
90 mm	64208.0900.5011
95 mm	64208.0900.5012
100 mm	64208.0900.5013

Standard hosszúság	Cikkszám
200 mm	64208.0900.5014
275 mm	64208.0900.5015
300 mm	64208.0900.5002
515 mm	64208.0900.5016
1025 mm szek.	64208.0900.5000



$F_{max} 30^\circ = 250 \text{ kN/m}$



35,5 kg/m



Szerszámbetét 13 mm



V900/10C

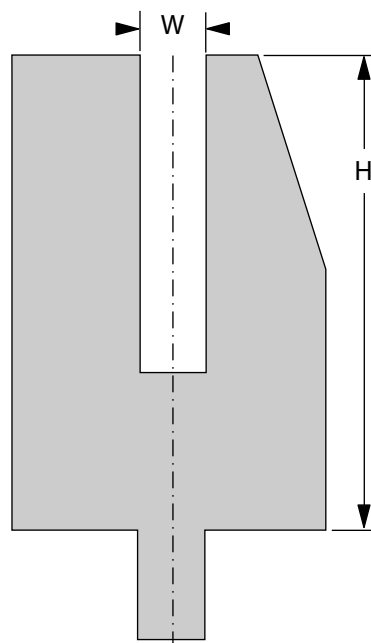

[B] Szélesség (mm) 55

[H] Magasság (mm) 85

Standard hosszúság	Cikkszám
50 mm	64208.0900.5032
55 mm	64208.0900.5033
60 mm	64208.0900.5034
65 mm	64208.0900.5047
70 mm	64208.0900.5035
75 mm	64208.0900.5036
80 mm	64208.0900.5037
85 mm	64208.0900.5038
90 mm	64208.0900.5039
95 mm	64208.0900.5040
100 mm	64208.0900.5041

Standard hosszúság	Cikkszám
200 mm	64208.0900.5042
275 mm	64208.0900.5043
300 mm	64208.0900.5044
515 mm	64208.0900.5045
1025 mm szek.	64208.0900.5046



F max 30° = 250 kN/m



32,0 kg/m



Szerszámbetét 13 mm



V900/12C

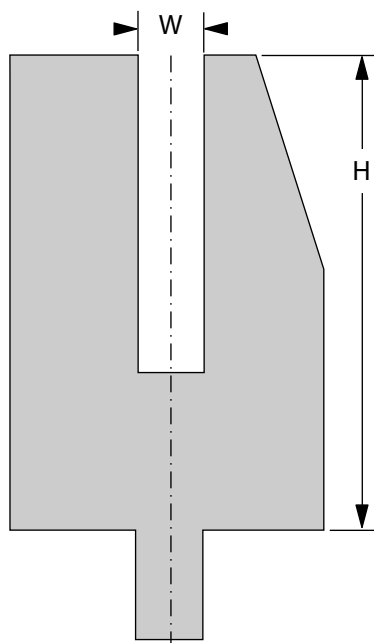

[B] Szélesség (mm)	55
[H] Magasság (mm)	85

Standard hosszúság	Cikkszám
50 mm	64208.0900.5017
55 mm	64208.0900.5018
60 mm	64208.0900.5019
65 mm	64208.0900.5020
70 mm	64208.0900.5021
75 mm	64208.0900.5022
80 mm	64208.0900.5023
85 mm	64208.0900.5024
90 mm	64208.0900.5025
95 mm	64208.0900.5026
100 mm	64208.0900.5027

Standard hosszúság	Cikkszám
200 mm	64208.0900.5028
275 mm	64208.0900.5029
300 mm	64208.0900.5001
515 mm	64208.0900.5030
1025 mm szek.	64208.0900.5031



$F_{max} 30^\circ = 250 \text{ kN/m}$



31,0 kg/m



Szerszámbetét 13 mm



Kapcsolatfelvételi adatok világszerte

Bystronic Laser AG
Industriestrasse 21
3362 Niederönz
Svájc
Tel. +41 62 956 33 33
E-mail info.laser@bystronic.com

Bystronic Australia Pty. Ltd.
4 Latchford Street
Cranbourne West VIC 3977
Ausztrália
Tel.: +61 1300 975 761
E-mail info.au@bystronic.com

Bystronic Austria GmbH
Schärdinger Straße 15
4061 Pasching
Ausztria
Tel. +43 7229 64411
E-mail office.at@bystronic.com

Bystronic do Brasil Ltda.
Rua Parma 203
83413-587 – Colombo – PR
Brazília
Tel. +55 41 3666 9000
E-mail bystronic.br@bystronic.com

Bystronic Canada Ltd
3330 Ridgeway Drive, Unit #11
Mississauga, ON L5L 5Z9
Kanada
Tel: +1 905 890 2999
E-mail sales.canada@bystronic.com

Bystronic(Tianjin) Laser Ltd.
No. 46 Xishi Road
Airport Industrial Park
300308 Tianjin
Kína
Tel: +86 22 5980 1888
E-mail info.tj.cn@bystronic.com

Bystronic Czech Republic s.r.o.
Turanka 115/1222
627 00 Brno Slatina
Cseh Köztársaság
Tel. +420 532 123 314
E-mail info.cz@bystronic.com

Bystronic Ibérica, S.A.
Avda. Tenerife nº 2
Edificio 1, Planta 3, Oficina D
28700 San Sebastián de los Reyes
(Madrid) Spanyolország
Tel. +34 91 654 48 78
E-mail sales.es@bystronic.com

Bystronic France SAS
Parc Technopolis
3, Avenue du Canada
91940 Les Ulis Cedex
Franciaország
Tel. +33 1 69 41 99 84
E-mail info.fr@bystronic.com

Bystronic Maschinenbau GmbH
Mühlhäuser Strasse 3
99867 Gotha
Németország
Tel. +49 3621 38 30
E-mail info.bending@bystronic.com

Bystronic Deutschland GmbH
Römerstrasse 14
71296 Heimsheim
Németország
Tel. +49 7033 46 99 0
E-mail info.de@bystronic.com

Bystronic Magyarország Kft.
Budaörs Business Center
Puskás Tivadar út 5.
2040 Budaörs
Magyarország
Tel: +36 23 610 433
E-mail info.hu@bystronic.com

Bystronic Laser India (Pvt) Ltd.
7C, Tadiwala Road
A Hotel Pancharatna mellett
Pune 411 001
India
Tel: +91 20 67294800
E-mail info.in@bystronic.com

Bystronic Italia SRL
Via del Lavoro, 30
20813 Bovisio-Masciago
Olaszország
Tel. +39 0362 5993 1
E-mail sales.it@bystronic.com

Bystronic Japan, Ltd.
2-95-3 Inadaira Musashimurayama-shi
Tokyo 208-0023
Japán
Tel: +81 42 506 8271
E-mail Cesar.Mujica@bystronic.com





Bystronic Laser Pte. Ltd.

(képviselői iroda)
Level 8, MCT Tower, Sky Park,
One City, Jalan USJ 25/1
Subang Jaya
47650 Selangor
Malajzia
Tel: +60 3 8022 8268

Bystronic Mexico S.A. de C.V.

Helios 401 A, Parque Industrial FINSA
Apodaca
66600 Nuevo León
Mexikó
Tel. +52 81 2133 7600
E-mail sales.mexico@bystronic.com

Bystronic Benelux B.V.

Duurzaamheidsring 11
4231 EX Meerkerk
Hollandia
Tel. +31 184 611 020
E-mail sales.benelux@bystronic.com

Bystronic Korea, Ltd.

3F Bystronic Bldg,
32-18, LS-ro
91 Beon-gil, Dongan-gu Anyang-si
14119 Gyeonggi-do
Korea
Tel. +82 31 389 9800
E-mail info.kr@bystronic.com

Bystronic Polska Sp. z o.o.

Ul. Sokolowska 47
PL-05-806 Sokolów
Lengyelország
Tel. +48 22 331 37 70
E-mail info.pl@bystronic.com

S.C. Bystronic Laser S.R.L.

Str. Poienelor no. 5
Ipari Pro Roman Park
500419 Brasov
Románia
Tel: +40 268 322 140
E-mail info.ro@bystronic.com

Bystronic Laser

Zorge Street, 9A
Stroenie 2 (Building 2)
125252 Moscow
Oroszország
Tel: +7 495 984 71 44
E-mail info.ru@bystronic.com

Bystronic Co., Ltd. (Shanghai)

Room 602, Part A,
388 North Fu Quan Road
Changning District
Sanghaj, 200335
Tel. +86 21 6082 9300
E-mail info.sha.cn@bystronic.com

Bystronic Pte. Ltd.

Thye Hong Központ
2 Leng Kee Road #02-04
159086 Szingapúr
Tel. +65 6472 6300
E-mail info.sg@bystronic.com

Bystronic Scandinavia AB

Metallvägen 30A
195 72 Rosersberg
Svédország
Tel: +46 (0)8 594 415 50
E-mail Services.SE@bystronic.com

Bystronic Sales AG

Industriestrasse 21
3362 Niederönz
Svájc
Tel. +41 62 956 37 83
E-mail info.sales@bystronic.com

Bystronic International Laser Ltd.

No. 66, Wuquan Rd.,
Wugu Dist.,
New Taipei City 248
Tajvan (TK)
Tel: +886 2 2299 2699
E-mail hotline.tw@bystronic.com

Bystronic Lazer ve Su Isinlari

Makineleri Sanayi ve Ticaret Ltd. Sti.
Serifali Mevkii, Barbaros Caddesi
No: 66 K:1
34775 Ümraniye/Istanbul
Törökország
Tel: +90 216 464 6160
E-mail info.tr@bystronic.com

LLC Bystronic Ukrajna

59 Zhylyanskaya Street
Diplomat Hall, 2nd floor, Office 207
1033 Kijev
Ukrajna
Tel. +380 44 569 74 37
E-mail info.cis@bystronic.com

Bystronic UK Ltd.

6 Wayside Business Park
Wilson's Lane
Coventry
Warwickshire CV6 6NY
Egyesült Királyság
Tel: +44 (0)844 848 5850
E-mail sales.uk@bystronic.com

Bystronic Inc.

2200 West Central Road
US-Hoffman Estates
IL 60192
Amerikai Egyesült Államok
Tel. +1 847 214 0300
E-mail sales.us@bystronic.com

Bystronic Vietnam Co. Ltd.

38/7 Truong Chinh Str.
Tan Thoi Nhat Ward
District 12
Hochiminh City
Vietnam
Tel: +84 28 3719 2278
E-mail Anhtuan.Ha@bystronic.com

