

Best choice.
Cutting. Bending. Automation.

Bystronic

Bystronic Tools RF-A

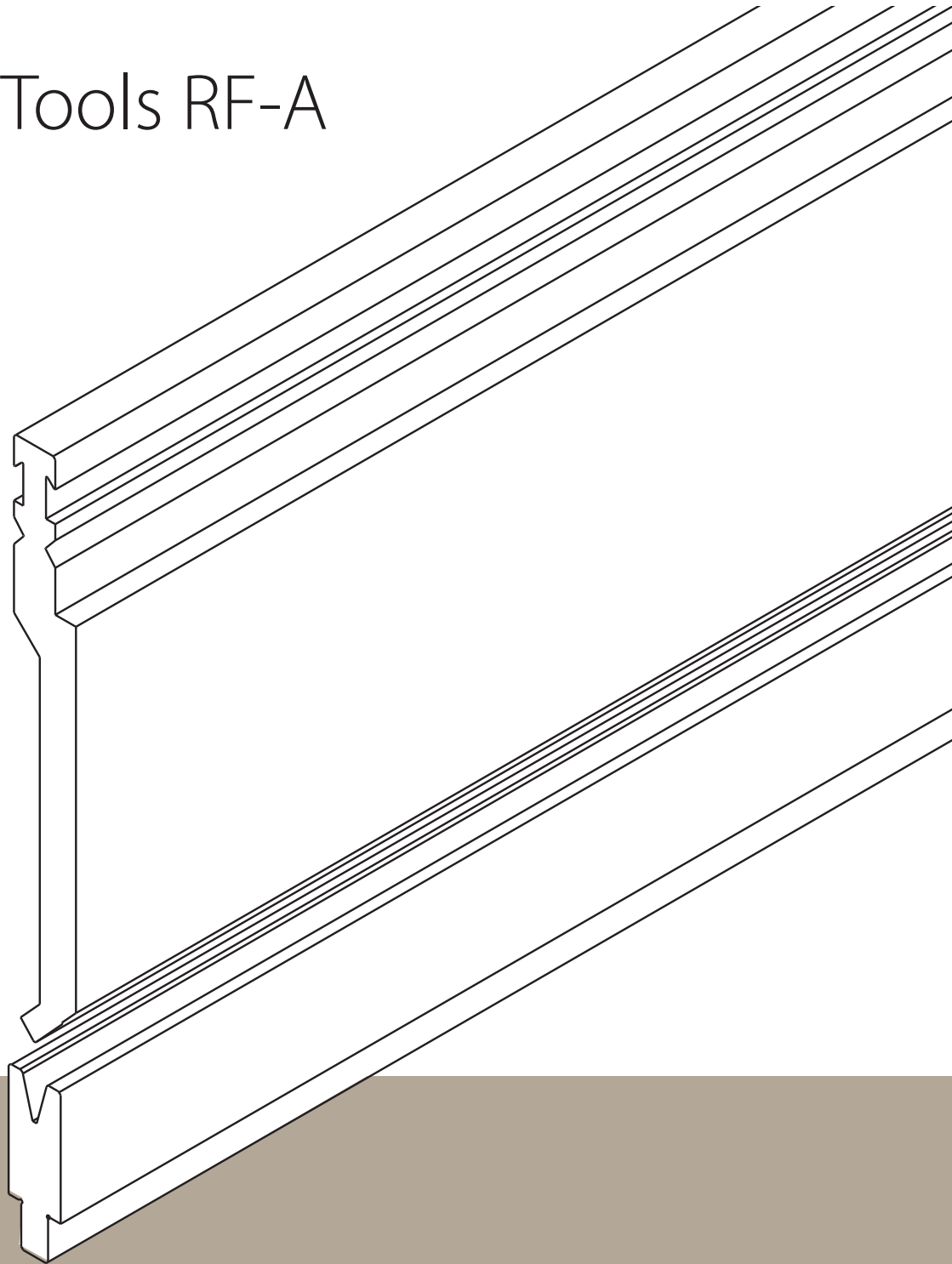

bystronic.com



Inhaltsverzeichnis

Grundlagen.....	3
Symbole in diesem Katalog.....	3
Angaben auf unseren Werkzeugen / Technische Parameter	3
Berechnungsgrundlagen für Freibiegen.....	4
Empfohlene Starter Kits	8
Klemmung RF-A.....	9
Teilungen Stempel	11
Oberwerkzeuge	12
Unterwerkzeuge.....	72
Untertischoptionen	74
Unterwerkzeugteilung.....	76
Zudrückwerkzeuge	150
Sonderbiegeworkzeuge.....	170
Hochleistungswerkzeuge	171
Kontakte weltweit	172



Grundlagen

Symbole in diesem Katalog



Härte: 58 bis 62 HRC



Max. zulässige Last



Werkzeugbelastungsart



Art der Belastung



Gewicht



Gedrehtes Einsetzen der Werkzeuge



Matrizenaufnahme

Angaben auf unseren Werkzeugen / Technische Parameter

Bystronic	
___ kN/m	→ Max. Biegekraft in kN/m
___ ≤ ___ °	→ Typ ≤ Winkel in °
R = ___ mm	→ Radius in mm
H = ___ mm	→ Höhe in mm
L = ___ mm	→ Länge in mm

Optische Werkzeuergenkennung – OTD

Es gibt ein Datenblatt for OTD, das unter der nebenstehenden Nummer bestellt werden kann.
Nur notwendig, wenn die Maschine mit dieser Option ausgestattet ist.



Berechnungsgrundlagen für Freibiegen

Kapazitätsdiagramm für das Freibiegen

Die angegebenen Daten wurden auf der Grundlage von Biegematerial mit einer Zugfestigkeit von $R_m = 420 \text{ N/mm}^2$ über eine Länge von 1 m berechnet.

V	6	8	10	12	16	18	20	24	32	40	50	60	80
R	1	1.2	1.6	2	2.5	2.8	3	3.5	5	6	8	9.5	12
t	F Biegekraft in kN / 1 m Biegelänge												
	a Mindestschenkellänge in mm												
0.5	25												
	4.3												
0.8	70	48											
	4.6	5.7											
1	115	80	60										
	5	6	7										
1.2		120	90	70									
		6	7.5	8.5									
1.5			150	120									
			8	9									
2.0				235	160	135	120	95					
				10	12	13	14.5	17					
2.5					265	225	200	155	110				
					12.5	14	15.5	17.5	23				
3.0							300	240	165	125			
							15.5	17.5	23.5	28			
4.0									315	235	180		
									25	29	35		
5.0									535	430	310	250	
									26	31	35.5	43	
6.0										610	450	360	
										32	36	44	
8.0											880	690	470
											40	46	57
10													800
													60
12													1200
													62
16													
18													
20													

Bei Blechen mit Walzzunder erhöht sich die Biegekraft um den Faktor 1.05 bis 1.1



100	120	130	140	150	160	180	190	200	230	260	290	320	V
15.5	19	21	23	24.5	26	28	30	32	36	40	45	50	R
F Biegekraft in kN / 1 m Biegelänge													t
a Mindestschenkellänge in mm													
													0.5
													0.8
													1
													1.2
													1.5
													2.0
													2.5
													3.0
													4.0
													5.0
													6.0
													8.0
360													8.0
71													10
600	470	430	390										10
71	85	92	100										12
900	710	650	580	550	500							12	
73	86	92	100	105	115							16	
	1400	1250	1150	1050	950	810	800	710	600				16
	90	98	105	110	115	130	135	140	160				18
			1480	1350	1250	1100	1000	950	800	700	600		18
			105	110	120	130	135	140	160	180	205		20
						1400	1300	1200	1000	900	850	700	20
						135	140	145	165	180	205	225	

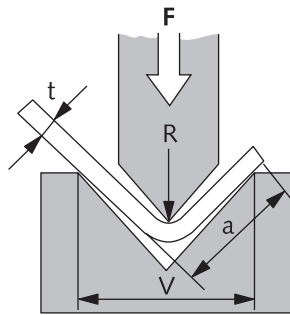

Der Innenradius R entspricht ca. 16 % der Matrizenöffnung V.



Berechnungsgrundlagen für Freibiegen

Berechnungsformeln

Empfohlene Matrizenöffnung V für Freibiegen

Materialstärke	t	0.5–2.5 mm	3–8 mm	9–10 mm	> 12 mm
Matrizenöffnung	V	6 × t	8 × t	10 × t	12 × t

Biegekraft für

Aluminium	Rm = 300 N/mm ²	F = F (Tabelle) × 0.65
Baustahl	Rm = 420 N/mm ²	F = F (Tisch)
Edelstahl	Rm = 700 N/mm ²	F = F (Tisch) × 1.6

Bestimmung der Biegekraft zum Freibiegen (Referenzdaten)

$$F = \frac{R_m \times t^2}{V} \times \left(1 + \frac{4 \times t}{V}\right)$$

Umrechnung: Rm = Zugfestigkeit in N/mm²

10 N = 1 kg

10 kN = 1 t

Umrechnung für minimale Innenradien R

Dicke t	1	2	3	4	5	6	8	10	12	16	18	20
Min. R	1	2	3	5	6	8	12	16	20	28	36	40



Zugfestigkeit

Material		Zugfestigkeit	
Amerikanisch	Europäisch	KPSI	N/mm ²
Aluminium 6061	Alu 50	42	290
Aluminium 5052	Alu 35	44	303
Baustahl 1010	DC01	53	366
A536-80 G 60-40-18	GGG-40	58	400
A 351 G CF 8	G-X 6CrNi 18 9	65	450
A 572 G50	S 355 MC	80	550
Domex 80	S 420 MC	80	550
A 36	S 235 JR	80	552
Edelstahl 304	Inox V2A	85	586
Edelstahl 316	Inox V4A	87	600
A 572 G 65	S 460 MC	95	655
Domex 100	S 500 MC	102	700
Domex 550	S 550 MC	110	760
Domex 600	S 600 MC	119	820
Weldox 700	Weldox 700	123	850
Domex 650	S 650 MC	128	880
Domex 700	S 700 MC	138	950
4140 niedriglegiert	42 CrMo 4	145	1000
Weldox 900	Weldox 900	149	1030
Weldox 960	Weldox 960	154	1060
Hardox 400	Hardox 400	181	1250
Hardox 500	Hardox 500	225	1550

Bitte fragen Sie zum Biegen hochfester Werkstoffe Ihren zuständigen Berater.



Empfohlene Starter Kits

Biegelänge	Teilenummer	Bezeichnung	Stück	Einheit
2050 mm	65206.0005.5007	Stempel P5 RF-A/30° L=515	4	Stück
	65206.0005.0003	Stempel P5 RF-A/30° L=1000 sect. FSC	1	Stück
	64201.0012.3009	Matrize V12/30° L=1030	2	Stück
	64201.0012.0002	Matrize V12/30° L=1000 sect. FSC	1	Stück
2550 mm	65206.0005.5007	Stempel P5 RF-A/30° L=515	5	Stück
	65206.0005.0003	Stempel P5 RF-A/30° L=1000 sect. FSC	1	Stück
	64201.0012.3009	Matrize V12/30° L=1030	2	Stück
	64201.0012.0002	Matrize V12/30° L=1000 sect. FSC	1	Stück
3100 mm	65206.0005.5007	Stempel P5 RF-A/30° L=515	6	Stück
	65206.0005.0003	Stempel P5 RF-A/30° L=1000 sect. FSC	1	Stück
	64201.0012.3009	Matrize V12/30° L=1030	3	Stück
	64201.0012.0002	Matrize V12/30° L=1000 sect. FSC	1	Stück
4100 mm	65206.0005.5007	Stempel P5 RF-A/30° L=515	8	Stück
	65206.0005.0003	Stempel P5 RF-A/30° L=1000 sect. FSC	1	Stück
	64201.0012.3009	Matrize V12/30° L=1030	4	Stück
	64201.0012.0002	Matrize V12/30° L=1000 sect. FSC	1	Stück



Klemmung RF-A

RF-A Pro

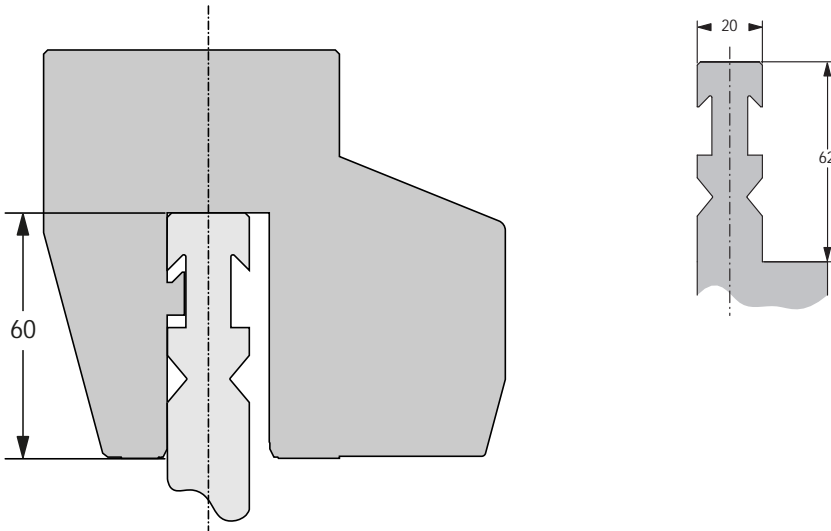

Kopftragende Last



Max. zulässige Last: 1800 kN/m kopftragend



Keine Härtung der Klemmung



Klemmhöhe Werkzeug: 60 mm



Klemmung RF-A

RF-A HD

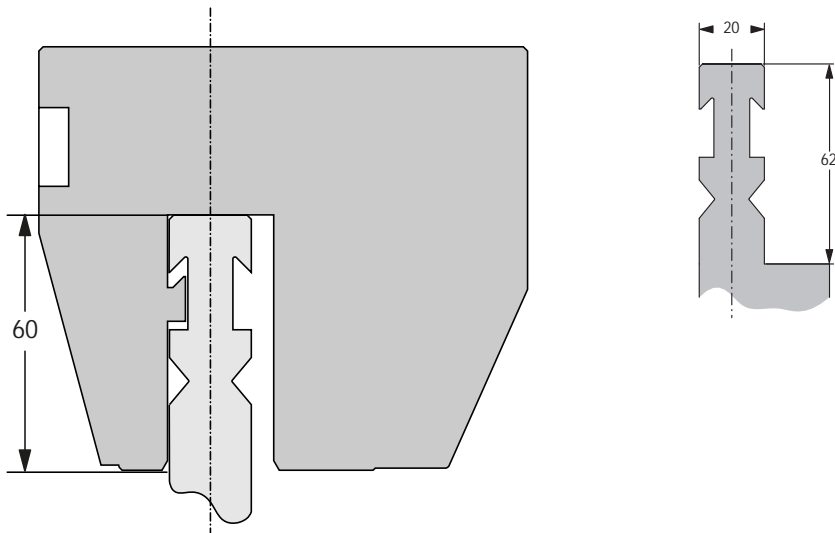

Kopf- und schultertragend



Max. zulässige Last:
2500 kN/m kopftragend, 3200 kN/m schultertragend



Druckfläche CNC-Deephardened® auf ca. 56°, HRC



Klemmhöhe Werkzeuge: 60 mm



Teilungen Stempel

Hörner R / RF / RF-A

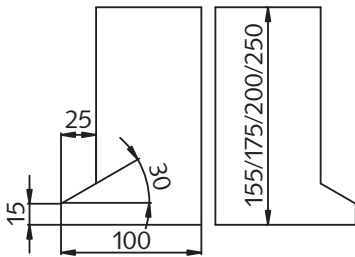

FSC / 1000 mm

(10 + 15 + 20 + 30 + 50 + 100 + 200 + 275 + 300)

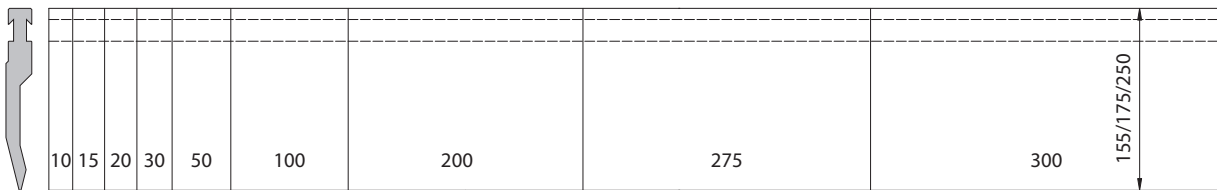

FSW / 550 mm*

(20 + 25 + 30 + 35 + 40 + 200 + 100 HL + 100 HR)

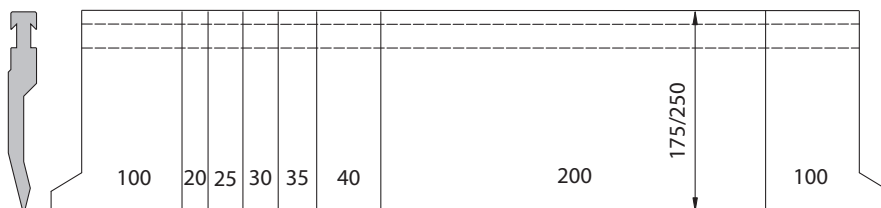

* Stempel P 12 und auch alle Radiuseinsätze ohne Hornstücke.
Diese Stücke werden durch Stücke 2 x 100 Millimeter ersetzt.

Sonderteilung auf Anfrage.



Oberwerkzeuge







P2 RF-A H175 R0.5

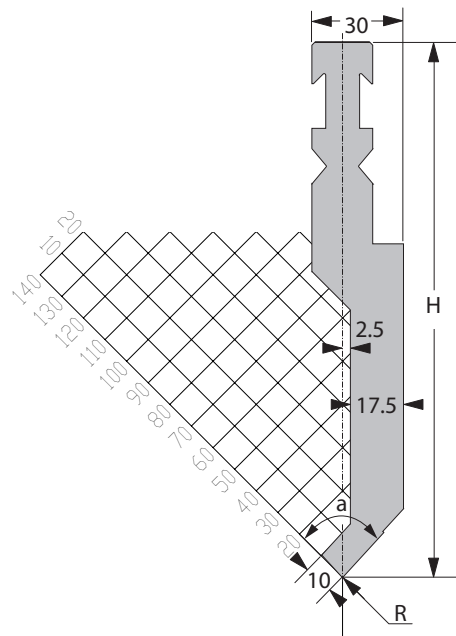
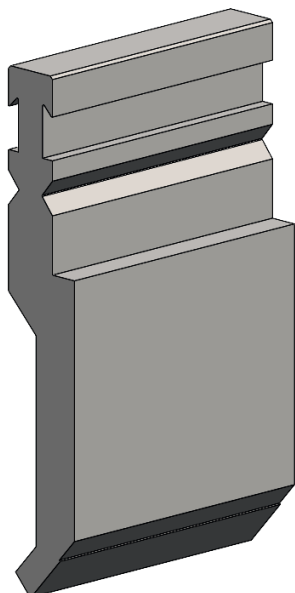

[R] Radius (mm)	0.5
Spitzenwinkel	85°
[H] Höhe (mm)	175

Bestell-Nr.	Vorderseite: 10170412
Datenblatt OTD	Rückseite: 10165553

Standardlänge	Teilenummer
10 mm	65206.0002.5145
15 mm	65206.0002.5146
20 mm	65206.0002.5147
25 mm	65206.0002.5148
30 mm	65206.0002.5149
35 mm	65206.0002.5150
40 mm	65206.0002.5151
45 mm	65206.0002.5152
50 mm	65206.0002.5153
55 mm	65206.0002.5154
60 mm	65206.0002.5155
65 mm	65206.0002.5156
70 mm	65206.0002.5157
75 mm	65206.0002.5158

Standardlänge	Teilenummer
80 mm	65206.0002.5159
85 mm	65206.0002.5160
90 mm	65206.0002.5161
95 mm	65206.0002.5162
100 mm	65206.0002.5163
200 mm	65206.0002.5076
275 mm	65206.0002.5164
300 mm	65206.0002.5165
515 mm	65206.0002.5035
1030 mm	65206.0002.3017
550 FSW	65206.0002.9003
1000 FSC	65206.0002.0037
100 Horn	65206.0002.7018



F max = 850 kN/m



24.0 kg/m



P2 RF-A H250 R0.5

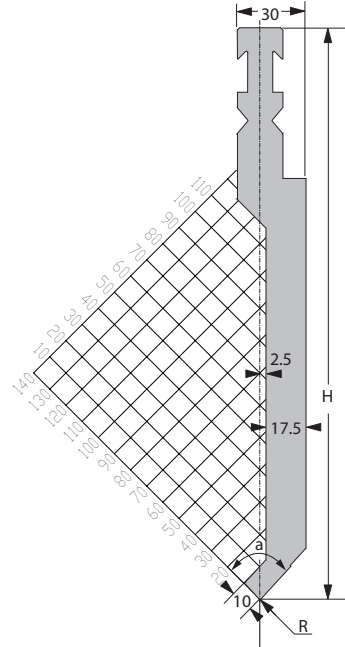
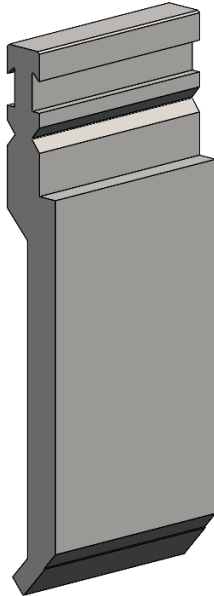

[R] Radius (mm)	0.5
Spitzenwinkel	85°
[H] Höhe (mm)	250

Bestell-Nr.	Vorderseite: 10170413
Datenblatt OTD	Rückseite: 10165640

Standardlänge	Teilenummer
10 mm	65206.0002.5166
15 mm	65206.0002.5167
20 mm	65206.0002.5168
25 mm	65206.0002.5169
30 mm	65206.0002.5170
35 mm	65206.0002.5171
40 mm	65206.0002.5172
45 mm	65206.0002.5173
50 mm	65206.0002.5174
55 mm	65206.0002.5175
60 mm	65206.0002.5176
65 mm	65206.0002.5177
70 mm	65206.0002.5178
75 mm	65206.0002.5179

Standardlänge	Teilenummer
80 mm	65206.0002.5180
85 mm	65206.0002.5181
90 mm	65206.0002.5182
95 mm	65206.0002.5183
100 mm	65206.0002.5184
200 mm	65206.0002.5078
275 mm	65206.0002.5185
300 mm	65206.0002.5186
515 mm	65206.0002.5055
1030 mm	65206.0002.3016
550 FSW	65206.0002.9005
1000 FSC	65206.0002.0027
100 Horn	65206.0002.7030



F max = 850 kN/m



34.4 kg/m



P2 RF-A H175 R0.5 Spitze 7 mm

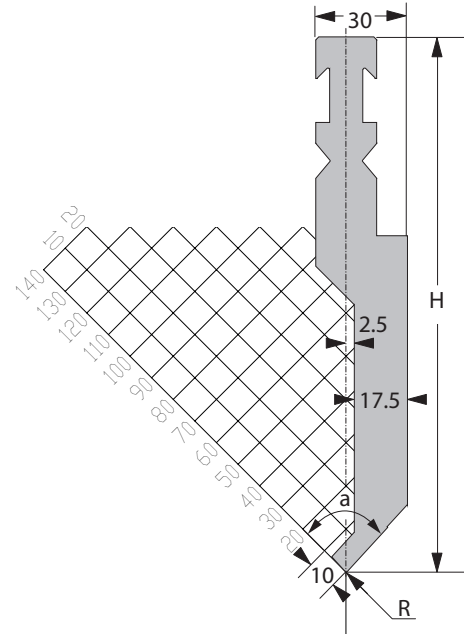
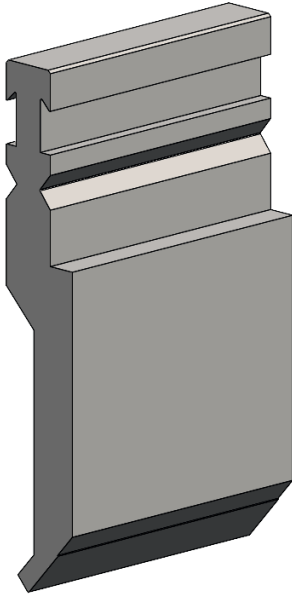

[R] Radius (mm)	0.5
Spitzenwinkel	85°
[H] Höhe (mm)	175

Bestell-Nr.	Vorderseite: 10170434
Datenblatt OTD	Rückseite: 10165671

Standardlänge	Teilenummer
10 mm	65206.0002.5187
15 mm	65206.0002.5188
20 mm	65206.0002.5189
25 mm	65206.0002.5190
30 mm	65206.0002.5191
35 mm	65206.0002.5192
40 mm	65206.0002.5193
45 mm	65206.0002.5194
50 mm	65206.0002.5195
55 mm	65206.0002.5196
60 mm	65206.0002.5197
65 mm	65206.0002.5198
70 mm	65206.0002.5199
75 mm	65206.0002.5200

Standardlänge	Teilenummer
80 mm	65206.0002.5201
85 mm	65206.0002.5202
90 mm	65206.0002.5203
95 mm	65206.0002.5204
100 mm	65206.0002.5205
200 mm	65206.0002.5077
275 mm	65206.0002.5206
300 mm	65206.0002.5207
515 mm	65206.0002.5075
1030 mm	65206.0002.3018
550 FSW	65206.0002.9004
1000 FSC	65206.0002.0029
100 Horn	65206.0002.7033



F max = 500 kN/m



24.0 kg/m



P2 RF-A H250 R0.5 Spitze 7 mm

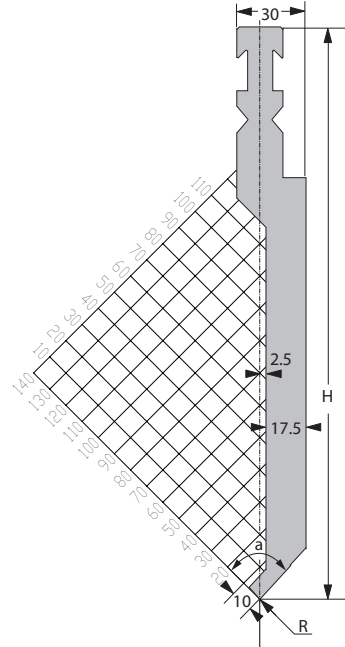
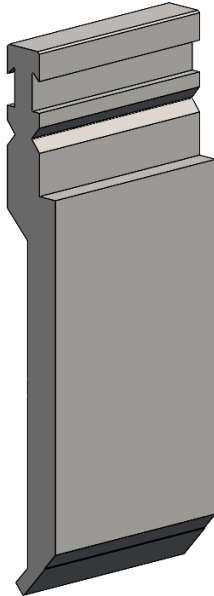

[R] Radius (mm)	0.5
Spitzenwinkel	85°
[H] Höhe (mm)	250

Bestell-Nr.	Vorderseite: 10170435
Datenblatt OTD	Rückseite: 10165672

Standardlänge	Teilenummer
10 mm	65206.0002.5208
15 mm	65206.0002.5209
20 mm	65206.0002.5210
25 mm	65206.0002.5211
30 mm	65206.0002.5212
35 mm	65206.0002.5213
40 mm	65206.0002.5214
45 mm	65206.0002.5215
50 mm	65206.0002.5216
55 mm	65206.0002.5217
60 mm	65206.0002.5218
65 mm	65206.0002.5219
70 mm	65206.0002.5220
75 mm	65206.0002.5221

Standardlänge	Teilenummer
80 mm	65206.0002.5222
85 mm	65206.0002.5223
90 mm	65206.0002.5224
95 mm	65206.0002.5225
100 mm	65206.0002.5226
200 mm	65206.0002.5079
275 mm	65206.0002.5227
300 mm	65206.0002.5228
515 mm	65206.0002.5042
1030 mm	65206.0002.3019
550 FSW	65206.0002.9006
1000 FSC	65206.0002.0021
100 Horn	65206.0002.7020



F max = 550 kN/m



34.3 kg/m



P2 RF-A H175 R1.0

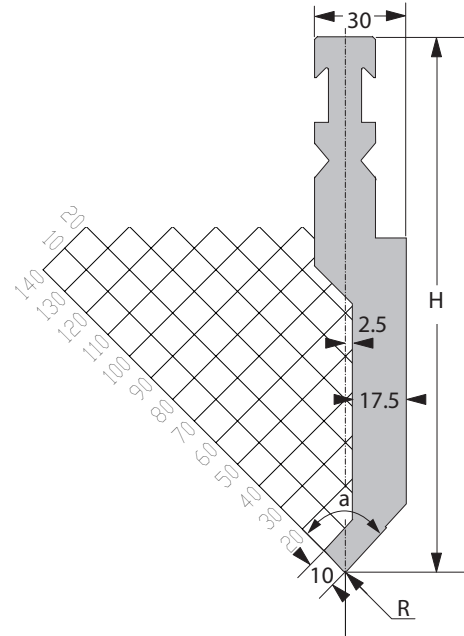
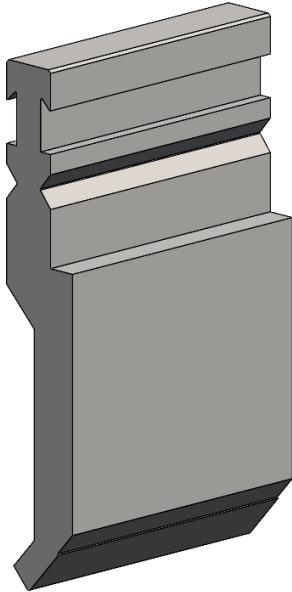

[R] Radius (mm)	1.0
Spitzenwinkel	85°
[H] Höhe (mm)	175

Bestell-Nr.	Vorderseite: 10170410
Datenblatt OTD	Rückseite: 10163807

Standardlänge	Teilenummer
10 mm	65206.0002.5108
15 mm	65206.0002.5109
20 mm	65206.0002.5110
25 mm	65206.0002.5111
30 mm	65206.0002.5112
35 mm	65206.0002.5113
40 mm	65206.0002.5114
45 mm	65206.0002.5115
50 mm	65206.0002.5116
55 mm	65206.0002.5117
60 mm	65206.0002.5118
65 mm	65206.0002.5119
70 mm	65206.0002.5120
75 mm	65206.0002.5121

Standardlänge	Teilenummer
80 mm	65206.0002.5122
85 mm	65206.0002.5123
90 mm	65206.0002.5124
95 mm	65206.0002.5125
100 mm	65206.0002.5126
200 mm	65206.0002.5088
275 mm	65206.0002.5127
300 mm	65206.0002.5128
515 mm	65206.0002.5001
1030 mm	65206.0002.3004
550 FSW	65206.0002.9001
1000 FSC	65206.0002.0003
100 Horn	65206.0002.7001



F max = 1000 kN/m



24.1 kg/m



P2 RF-A H250 R1.0

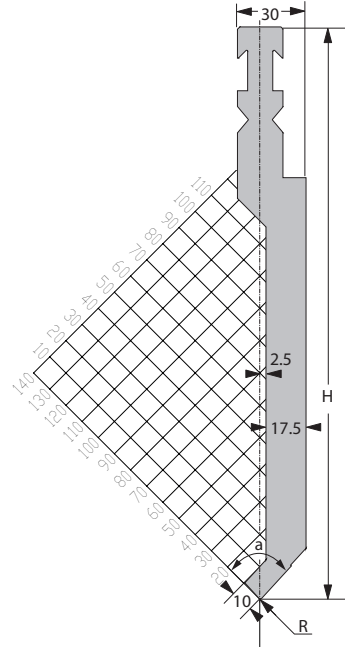
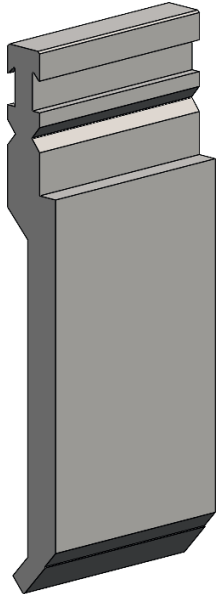

[R] Radius (mm)	1.0
Spitzenwinkel	85°
[H] Höhe (mm)	250

Bestell-Nr.	Vorderseite: 10170411
Datenblatt OTD	Rückseite: 10165545

Standardlänge	Teilenummer
10 mm	65206.0002.5057
15 mm	65206.0002.5129
20 mm	65206.0002.5041
25 mm	65206.0002.5130
30 mm	65206.0002.5131
35 mm	65206.0002.5132
40 mm	65206.0002.5133
45 mm	65206.0002.5134
50 mm	65206.0002.5102
55 mm	65206.0002.5135
60 mm	65206.0002.5136
65 mm	65206.0002.5137
70 mm	65206.0002.5138
75 mm	65206.0002.5139

Standardlänge	Teilenummer
80 mm	65206.0002.5140
85 mm	65206.0002.5141
90 mm	65206.0002.5142
95 mm	65206.0002.5143
100 mm	65206.0002.5049
200 mm	65206.0002.5089
275 mm	65206.0002.5144
300 mm	65206.0002.5103
515 mm	65206.0002.5005
1030 mm	65206.0002.3009
550 FSW	65206.0002.9002
1000 FSC	65206.0002.0001
100 Horn	65206.0002.7003



F max = 1000 kN/m



34.4 kg/m



P3 RF-A H175 R1.0

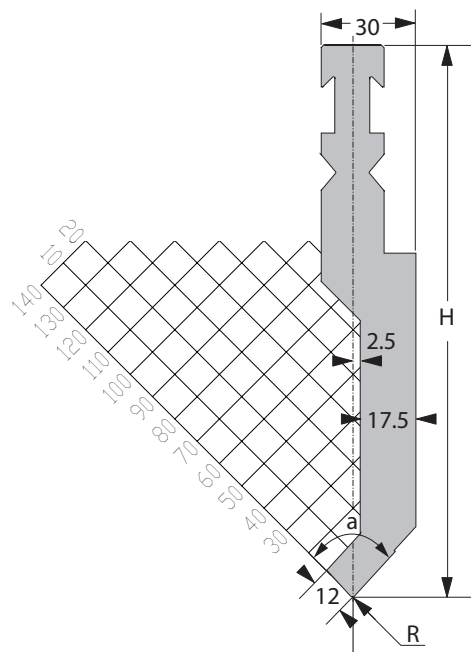
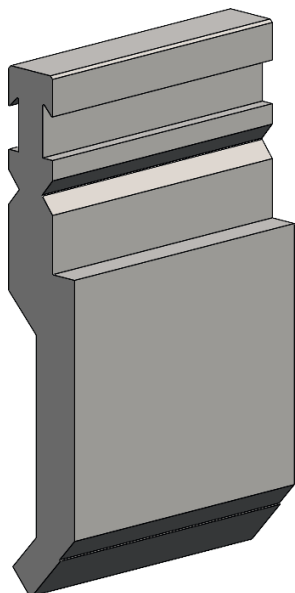

[R] Radius (mm)	1.0
Spitzenwinkel	85°
[H] Höhe (mm)	175

Bestell-Nr.	Vorderseite: 10170414
Datenblatt OTD	Rückseite: 10165673

Standardlänge	Teilenummer
10 mm	65206.0003.5097
15 mm	65206.0003.5098
20 mm	65206.0003.5099
25 mm	65206.0003.5100
30 mm	65206.0003.5101
35 mm	65206.0003.5102
40 mm	65206.0003.5103
45 mm	65206.0003.5104
50 mm	65206.0003.5105
55 mm	65206.0003.5106
60 mm	65206.0003.5107
65 mm	65206.0003.5108
70 mm	65206.0003.5109
75 mm	65206.0003.5110

Standardlänge	Teilenummer
80 mm	65206.0003.5111
85 mm	65206.0003.5112
90 mm	65206.0003.5113
95 mm	65206.0003.5114
100 mm	65206.0003.5115
200 mm	65206.0003.5116
275 mm	65206.0003.5117
300 mm	65206.0003.5118
515 mm	65206.0003.5005
1030 mm	65206.0003.3005
550 FSW	65206.0003.9001
1000 FSC	65206.0003.0002
100 Horn	65206.0003.7006



F max = 1300 kN/m



24.5 kg/m



P3 RF-A H250 R1.0

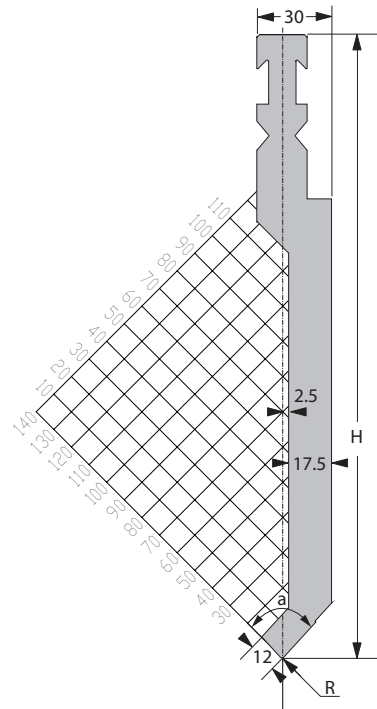
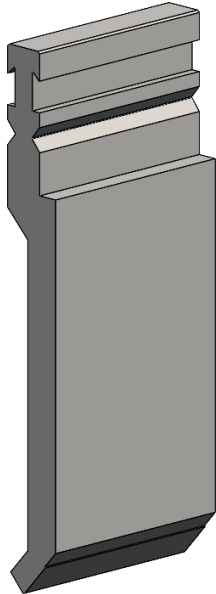

[R] Radius (mm)	1.0
Spitzenwinkel	85°
[H] Höhe (mm)	250

Bestell-Nr.	Vorderseite: 10170415
Datenblatt OTD	Rückseite: 10165674

Standardlänge	Teilenummer
10 mm	65206.0003.5119
15 mm	65206.0003.5120
20 mm	65206.0003.5121
25 mm	65206.0003.5122
30 mm	65206.0003.5123
35 mm	65206.0003.5124
40 mm	65206.0003.5125
45 mm	65206.0003.5126
50 mm	65206.0003.5127
55 mm	65206.0003.5128
60 mm	65206.0003.5129
65 mm	65206.0003.5130
70 mm	65206.0003.5131
75 mm	65206.0003.5132

Standardlänge	Teilenummer
80 mm	65206.0003.5133
85 mm	65206.0003.5134
90 mm	65206.0003.5135
95 mm	65206.0003.5136
100 mm	65206.0003.5031
200 mm	65206.0003.5137
275 mm	65206.0003.5138
300 mm	65206.0003.5139
515 mm	65206.0003.5003
1030 mm	65206.0003.3004
550 FSW	65206.0003.9002
1000 FSC	65206.0003.0009
100 Horn	65206.0003.7002



F max = 1400 kN/m



34.6 kg/m



P3 RF-A H175 R3.0

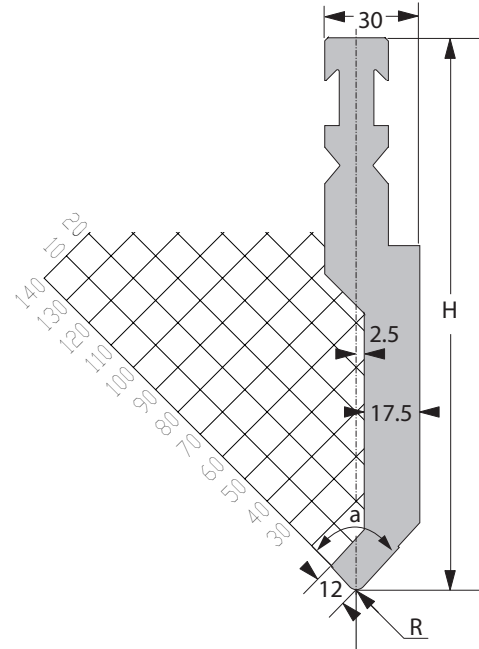
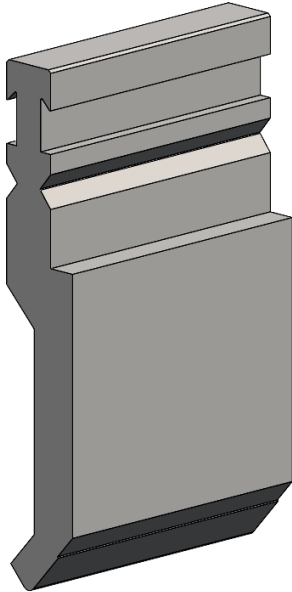

[R] Radius (mm)	3.0
Spitzenwinkel	85°
[H] Höhe (mm)	175

Bestell-Nr.	Vorderseite: 10170416
Datenblatt OTD	Rückseite: 10165675

Standardlänge	Teilenummer
10 mm	65206.0003.5140
15 mm	65206.0003.5141
20 mm	65206.0003.5142
25 mm	65206.0003.5143
30 mm	65206.0003.5144
35 mm	65206.0003.5145
40 mm	65206.0003.5146
45 mm	65206.0003.5147
50 mm	65206.0003.5148
55 mm	65206.0003.5149
60 mm	65206.0003.5150
65 mm	65206.0003.5151
70 mm	65206.0003.5152
75 mm	65206.0003.5153

Standardlänge	Teilenummer
80 mm	65206.0003.5154
85 mm	65206.0003.5155
90 mm	65206.0003.5156
95 mm	65206.0003.5157
100 mm	65206.0003.5158
200 mm	65206.0003.5159
275 mm	65206.0003.5160
300 mm	65206.0003.5161
515 mm	65206.0003.5027
1030 mm	65206.0003.3006
550 FSW	65206.0003.9008
1000 FSC	65206.0003.0021
100 Horn	65206.0003.7015

F_{max} = 1100 kN/m

24.2 kg/m



P3 RF-A H250 R3.0

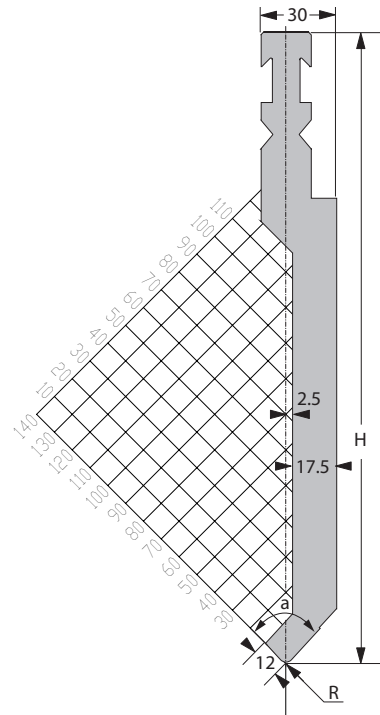
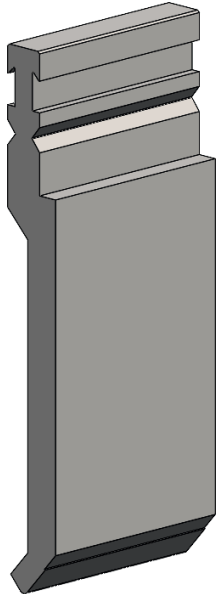

[R] Radius (mm)	3.0
Spitzenwinkel	85°
[H] Höhe (mm)	250

Bestell-Nr.	Vorderseite: 10170417
Datenblatt OTD	Rückseite: 10165676

Standardlänge	Teilenummer
10 mm	65206.0003.5162
15 mm	65206.0003.5163
20 mm	65206.0003.5164
25 mm	65206.0003.5165
30 mm	65206.0003.5166
35 mm	65206.0003.5167
40 mm	65206.0003.5168
45 mm	65206.0003.5169
50 mm	65206.0003.5170
55 mm	65206.0003.5171
60 mm	65206.0003.5172
65 mm	65206.0003.5173
70 mm	65206.0003.5174
75 mm	65206.0003.5175

Standardlänge	Teilenummer
80 mm	65206.0003.5176
85 mm	65206.0003.5177
90 mm	65206.0003.5178
95 mm	65206.0003.5179
100 mm	65206.0003.5180
200 mm	65206.0003.5181
275 mm	65206.0003.5182
300 mm	65206.0003.5183
515 mm	65206.0003.5016
1030 mm	65206.0003.3008
550 FSW	65206.0003.9004
1000 FSC	65206.0003.0013
100 Horn	65206.0003.7009



F max = 1000 kN/m



34.5 kg/m



P4 RF-A H175 R0.5

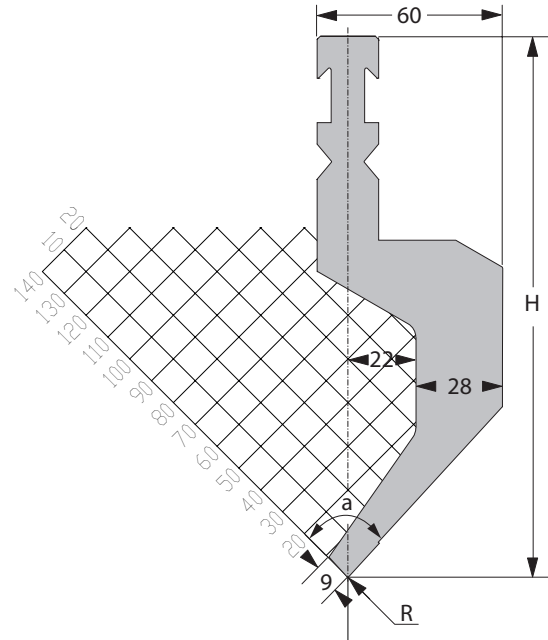
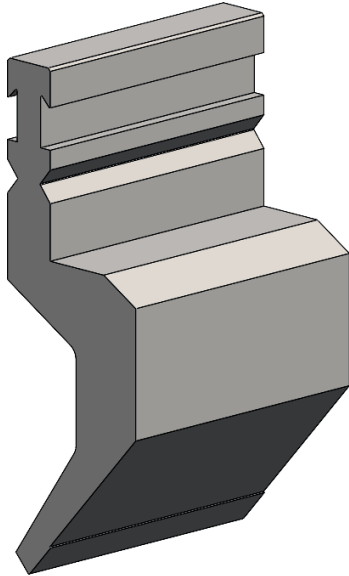

[R] Radius (mm)	0.5
Spitzenwinkel	85°
[H] Höhe (mm)	175

Bestell-Nr.	Vorderseite: 10170420
Datenblatt OTD	Rückseite: 10165686

Standardlänge	Teilenummer
10 mm	65206.0004.5324
15 mm	65206.0004.5325
20 mm	65206.0004.5326
25 mm	65206.0004.5327
30 mm	65206.0004.5328
35 mm	65206.0004.5329
40 mm	65206.0004.5330
45 mm	65206.0004.5331
50 mm	65206.0004.5332
55 mm	65206.0004.5333
60 mm	65206.0004.5334
65 mm	65206.0004.5335
70 mm	65206.0004.5336
75 mm	65206.0004.5337

Standardlänge	Teilenummer
80 mm	65206.0004.5338
85 mm	65206.0004.5339
90 mm	65206.0004.5340
95 mm	65206.0004.5341
100 mm	65206.0004.5342
200 mm	65206.0004.5213
275 mm	65206.0004.5343
300 mm	65206.0004.5344
515 mm	65206.0004.5107
1030 mm	65206.0004.3030
550 FSW	65206.0004.9015
1000 FSC	65206.0004.0080
100 Horn	65206.0004.7040



F max = 550 kN/m



31.5 kg/m



P4 RF-A H250 R0.5

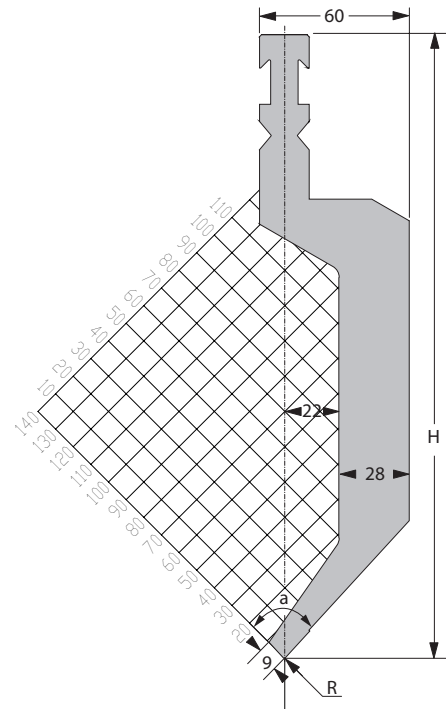
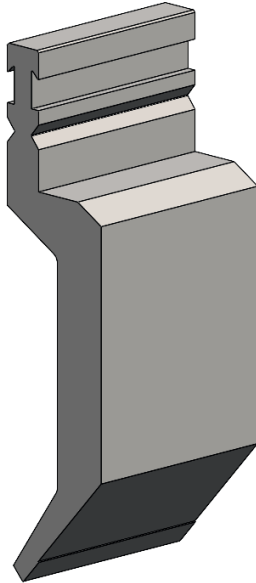

[R] Radius (mm)	0.5
Spitzenwinkel	85°
[H] Höhe (mm)	250

Bestell-Nr. Datenblatt OTD	Vorderseite: 10170421
	Rückseite: 10165687

Standardlänge	Teilenummer
10 mm	65206.0004.5345
15 mm	65206.0004.5346
20 mm	65206.0004.5347
25 mm	65206.0004.5348
30 mm	65206.0004.5349
35 mm	65206.0004.5350
40 mm	65206.0004.5351
45 mm	65206.0004.5352
50 mm	65206.0004.5353
55 mm	65206.0004.5354
60 mm	65206.0004.5355
65 mm	65206.0004.5356
70 mm	65206.0004.5357
75 mm	65206.0004.5358

Standardlänge	Teilenummer
80 mm	65206.0004.5359
85 mm	65206.0004.5360
90 mm	65206.0004.5361
95 mm	65206.0004.5362
100 mm	65206.0004.5363
200 mm	65206.0004.5214
275 mm	65206.0004.5364
300 mm	65206.0004.5365
515 mm	65206.0004.5092
1030 mm	65206.0004.3031
550 FSW	65206.0004.9016
1000 FSC	65206.0004.0075
100 Horn	65206.0004.7048



F max = 550 kN/m



48.0 kg/m



P4 RF-A H175 R1.0

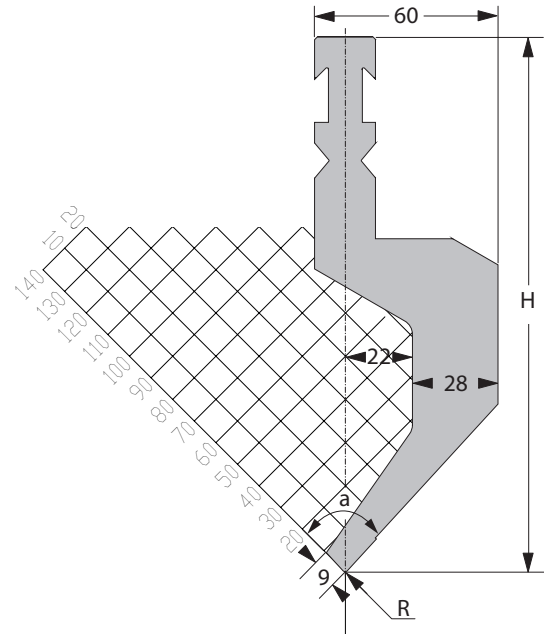
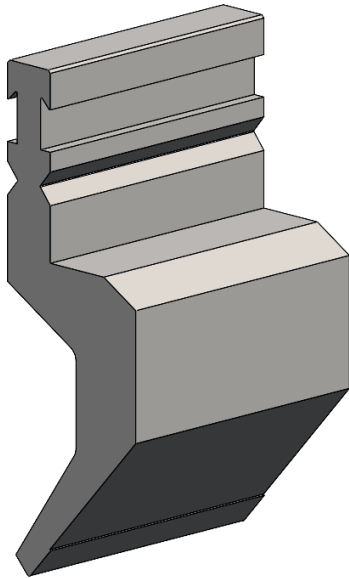

[R] Radius (mm)	1.0
Spitzenwinkel	85°
[H] Höhe (mm)	175

Bestell-Nr.	Vorderseite: 10170422
Datenblatt OTD	Rückseite: 10165688

Standardlänge	Teilenummer
10 mm	65206.0004.5366
15 mm	65206.0004.5367
20 mm	65206.0004.5368
25 mm	65206.0004.5369
30 mm	65206.0004.5370
35 mm	65206.0004.5371
40 mm	65206.0004.5372
45 mm	65206.0004.5220
50 mm	65206.0004.5219
55 mm	65206.0004.5373
60 mm	65206.0004.5374
65 mm	65206.0004.5375
70 mm	65206.0004.5376
75 mm	65206.0004.5377

Standardlänge	Teilenummer
80 mm	65206.0004.5378
85 mm	65206.0004.5379
90 mm	65206.0004.5380
95 mm	65206.0004.5381
100 mm	65206.0004.5382
200 mm	65206.0004.5224
275 mm	65206.0004.5383
300 mm	65206.0004.5082
515 mm	65206.0004.5013
1030 mm	65206.0004.3011
550 FSW	65206.0004.9027
1000 FSC	65206.0004.0006
100 Horn	65206.0004.7006



F max = 600 kN/m



32.2 kg/m



P4 RF-A H250 R1.0

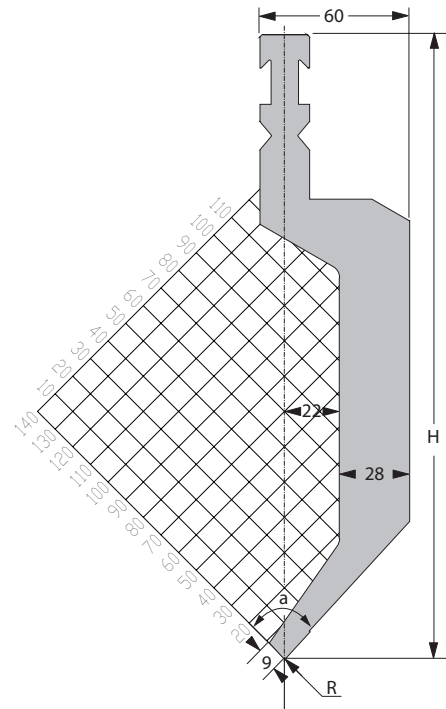
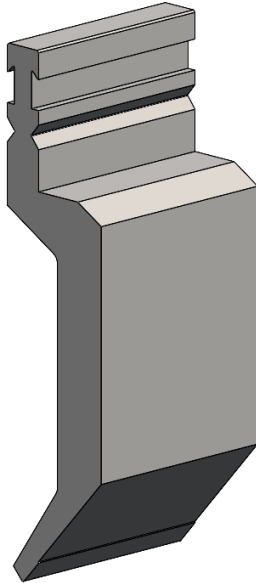

[R] Radius (mm)	1.0
Spitzenwinkel	85°
[H] Höhe (mm)	250

Bestell-Nr. Datenblatt OTD	Vorderseite: 10170423
	Rückseite: 10165689

Standardlänge	Teilenummer
10 mm	65206.0004.5384
15 mm	65206.0004.5385
20 mm	65206.0004.5386
25 mm	65206.0004.5245
30 mm	65206.0004.5269
35 mm	65206.0004.5270
40 mm	65206.0004.5271
45 mm	65206.0004.5272
50 mm	65206.0004.5273
55 mm	65206.0004.5387
60 mm	65206.0004.5388
65 mm	65206.0004.5389
70 mm	65206.0004.5390
75 mm	65206.0004.5391

Standardlänge	Teilenummer
80 mm	65206.0004.5392
85 mm	65206.0004.5393
90 mm	65206.0004.5394
95 mm	65206.0004.5395
100 mm	65206.0004.5274
200 mm	65206.0004.5176
275 mm	65206.0004.5396
300 mm	65206.0004.5081
515 mm	65206.0004.5012
1030 mm	65206.0004.3027
550 FSW	65206.0004.9019
1000 FSC	65206.0004.0008
100 Horn	65206.0004.7007



F max = 600 kN/m



48.7 kg/m



P4 RF-A H175 R1.5

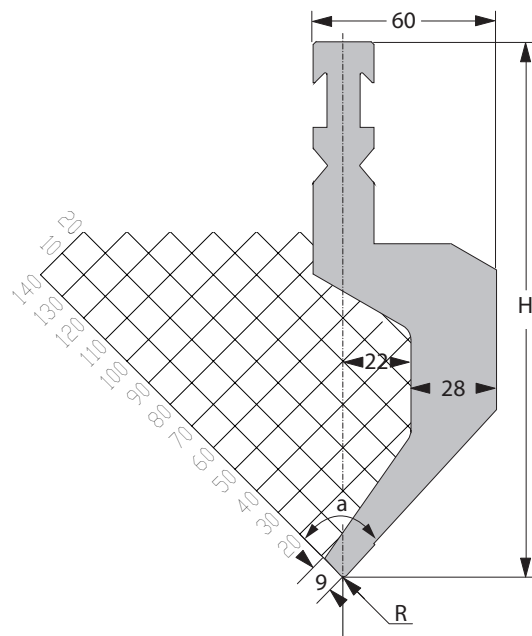
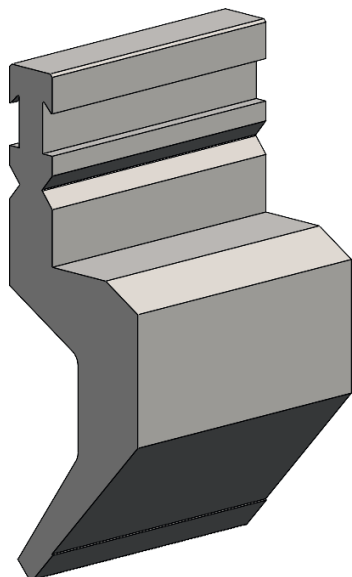

[R] Radius (mm)	1.5
Spitzenwinkel	85°
[H] Höhe (mm)	175

Bestell-Nr.	Vorderseite: 10170418
Datenblatt OTD	Rückseite: 10165682

Standardlänge	Teilenummer
10 mm	65206.0004.5175
15 mm	65206.0004.5183
20 mm	65206.0004.5182
25 mm	65206.0004.5301
30 mm	65206.0004.5181
35 mm	65206.0004.5302
40 mm	65206.0004.5287
45 mm	65206.0004.5303
50 mm	65206.0004.5063
55 mm	65206.0004.5304
60 mm	65206.0004.5305
65 mm	65206.0004.5306
70 mm	65206.0004.5307
75 mm	65206.0004.5308

Standardlänge	Teilenummer
80 mm	65206.0004.5309
85 mm	65206.0004.5310
90 mm	65206.0004.5311
95 mm	65206.0004.5312
100 mm	65206.0004.5180
200 mm	65206.0004.5179
275 mm	65206.0004.5313
300 mm	65206.0004.5058
515 mm	65206.0004.5005
1030 mm	65206.0004.3005
550 FSW	65206.0004.9001
1000 FSC	65206.0004.0003
100 Horn	65206.0004.7002



F max = 600 kN/m



31.8 kg/m



P4 RF-A H250 R1.5

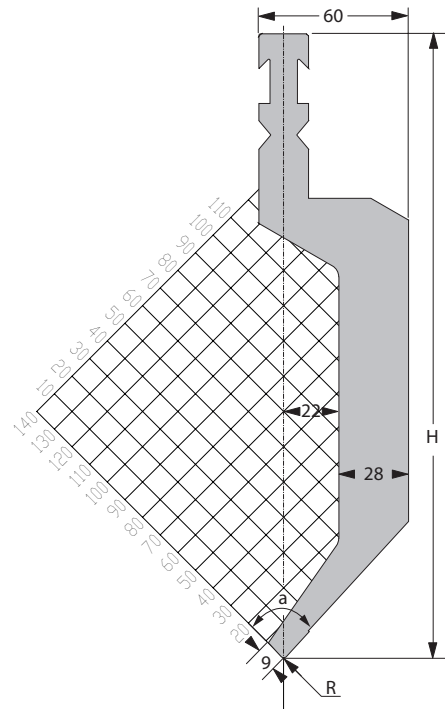
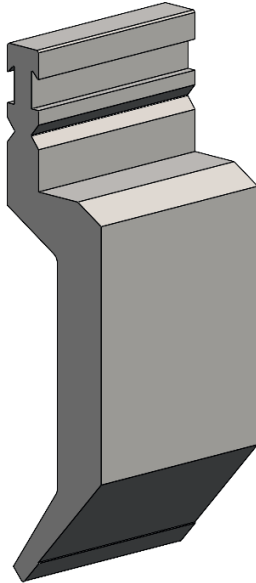

[R] Radius (mm)	1.5
Spitzenwinkel	85°
[H] Höhe (mm)	250

Bestell-Nr.	Vorderseite: 10170419
Datenblatt OTD	Rückseite: 10165684

Standardlänge	Teilenummer
10 mm	65206.0004.5172
15 mm	65206.0004.5173
20 mm	65206.0004.5174
25 mm	65206.0004.5276
30 mm	65206.0004.5204
35 mm	65206.0004.5277
40 mm	65206.0004.5278
45 mm	65206.0004.5314
50 mm	65206.0004.5016
55 mm	65206.0004.5315
60 mm	65206.0004.5316
65 mm	65206.0004.5317
70 mm	65206.0004.5318
75 mm	65206.0004.5319

Standardlänge	Teilenummer
80 mm	65206.0004.5320
85 mm	65206.0004.5321
90 mm	65206.0004.5322
95 mm	65206.0004.5323
100 mm	65206.0004.5017
200 mm	65206.0004.5134
275 mm	65206.0004.5072
300 mm	65206.0004.5037
515 mm	65206.0004.5007
1030 mm	65206.0004.3009
550 FSW	65206.0004.9002
1000 FSC	65206.0004.0004
100 Horn	65206.0004.7003



F max = 600 kN/m



48.3 kg/m



P4 RF-A H175 R3.0

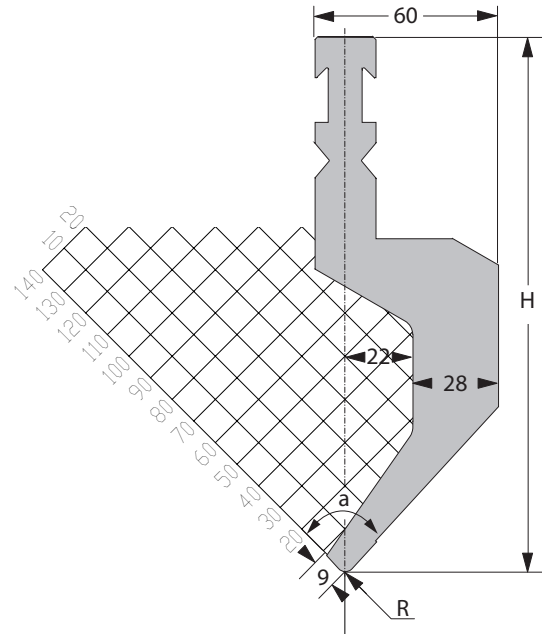
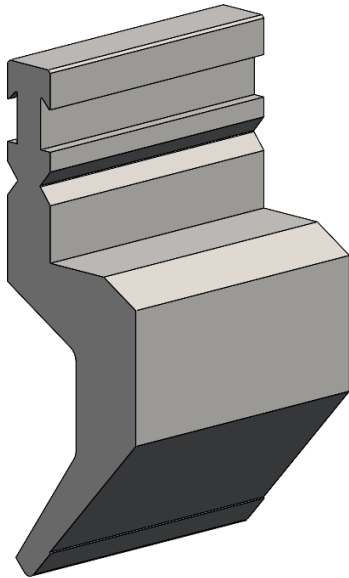

[R] Radius (mm)	3.0
Spitzenwinkel	85°
[H] Höhe (mm)	175

Bestell-Nr.	Vorderseite: 10170424
Datenblatt OTD	Rückseite: 10165690

Standardlänge	Teilenummer
10 mm	65206.0004.5397
15 mm	65206.0004.5398
20 mm	65206.0004.5399
25 mm	65206.0004.5400
30 mm	65206.0004.5401
35 mm	65206.0004.5402
40 mm	65206.0004.5403
45 mm	65206.0004.5404
50 mm	65206.0004.5405
55 mm	65206.0004.5406
60 mm	65206.0004.5407
65 mm	65206.0004.5408
70 mm	65206.0004.5409
75 mm	65206.0004.5410

Standardlänge	Teilenummer
80 mm	65206.0004.5411
85 mm	65206.0004.5412
90 mm	65206.0004.5413
95 mm	65206.0004.5414
100 mm	65206.0004.5415
200 mm	65206.0004.5189
275 mm	65206.0004.5416
300 mm	65206.0004.5417
515 mm	65206.0004.5064
1030 mm	65206.0004.3032
550 FSW	65206.0004.9014
1000 FSC	65206.0004.0054
100 Horn	65206.0004.7051



F max = 600 kN/m



32.0 kg/m



P4 RF-A H250 R3.0

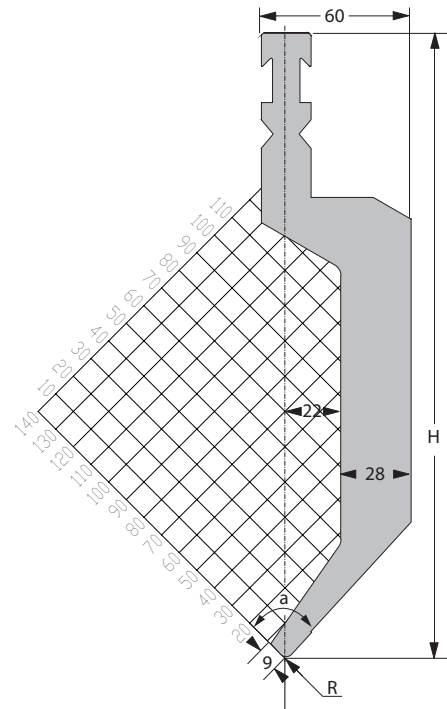
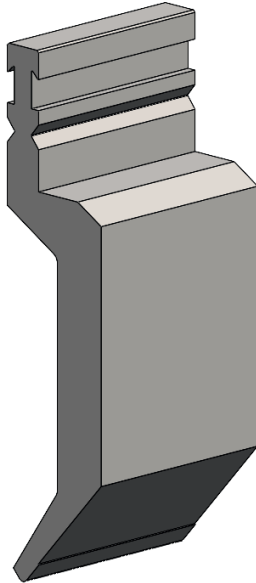

[R] Radius (mm)	3.0
Spitzenwinkel	85°
[H] Höhe (mm)	250

Bestell-Nr. Datenblatt OTD	Vorderseite: 10170425
	Rückseite: 10165691

Standardlänge	Teilenummer
10 mm	65206.0004.5418
15 mm	65206.0004.5419
20 mm	65206.0004.5420
25 mm	65206.0004.5421
30 mm	65206.0004.5422
35 mm	65206.0004.5423
40 mm	65206.0004.5424
45 mm	65206.0004.5425
50 mm	65206.0004.5426
55 mm	65206.0004.5427
60 mm	65206.0004.5428
65 mm	65206.0004.5429
70 mm	65206.0004.5430
75 mm	65206.0004.5431

Standardlänge	Teilenummer
80 mm	65206.0004.5432
85 mm	65206.0004.5433
90 mm	65206.0004.5434
95 mm	65206.0004.5435
100 mm	65206.0004.5436
200 mm	65206.0004.5437
275 mm	65206.0004.5438
300 mm	65206.0004.5194
515 mm	65206.0004.5011
1030 mm	65206.0004.3018
550 FSW	65206.0004.9009
1000 FSC	65206.0004.0010
100 Horn	65206.0004.7004



F max = 600 kN/m



48.5 kg/m



P5 RF-A H175 R0.5

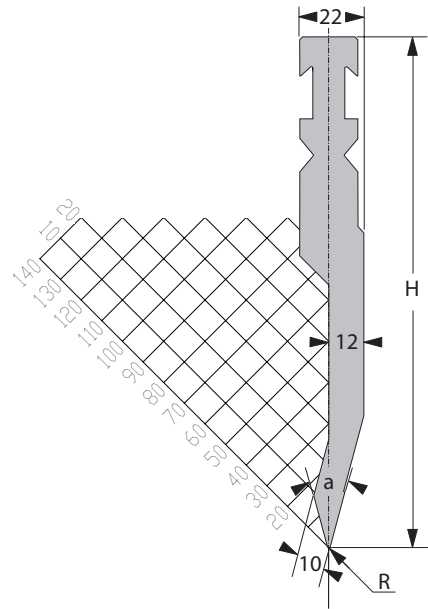
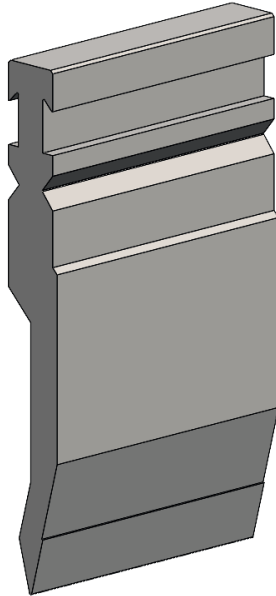

[R] Radius (mm)	0.5
Spitzenwinkel	30°
[H] Höhe (mm)	175

Bestell-Nr.	Vorderseite: 10170428
Datenblatt OTD	Rückseite: 10165694

Standardlänge	Teilenummer
10 mm	65206.0005.5182
15 mm	65206.0005.5183
20 mm	65206.0005.5184
25 mm	65206.0005.5211
30 mm	65206.0005.5185
35 mm	65206.0005.5212
40 mm	65206.0005.5213
45 mm	65206.0005.5214
50 mm	65206.0005.5186
55 mm	65206.0005.5215
60 mm	65206.0005.5216
65 mm	65206.0005.5217
70 mm	65206.0005.5218
75 mm	65206.0005.5219

Standardlänge	Teilenummer
80 mm	65206.0005.5220
85 mm	65206.0005.5221
90 mm	65206.0005.5222
95 mm	65206.0005.5223
100 mm	65206.0005.5224
200 mm	65206.0005.5169
275 mm	65206.0005.5225
300 mm	65206.0005.5226
515 mm	65206.0005.5046
1030 mm	65206.0005.3023
550 FSW	65206.0005.9011
1000 FSC	65206.0005.0050
100 Horn	65206.0005.7040

F_{max} = 700 kN/m

19.3 kg/m



P5 RF-A H250 R0.5

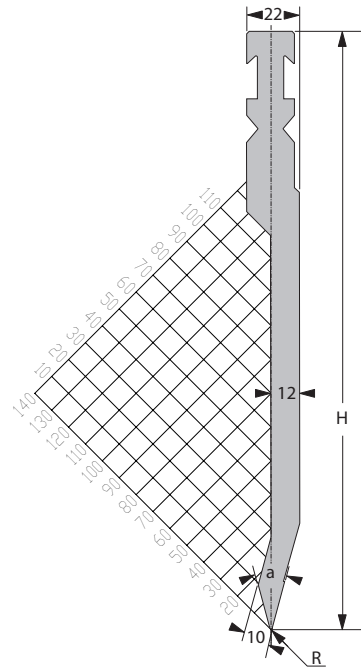
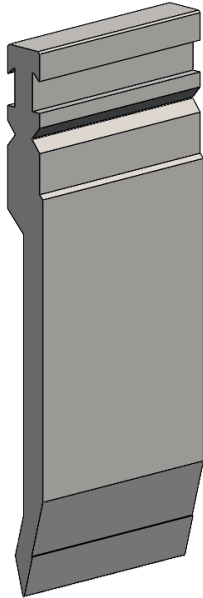

[R] Radius (mm)	0.5
Spitzenwinkel	30°
[H] Höhe (mm)	250

Bestell-Nr.	Vorderseite: 10170429
Datenblatt OTD	Rückseite: 10165695

Standardlänge	Teilenummer
10 mm	65206.0005.5193
15 mm	65206.0005.5227
20 mm	65206.0005.5228
25 mm	65206.0005.5229
30 mm	65206.0005.5230
35 mm	65206.0005.5231
40 mm	65206.0005.5232
45 mm	65206.0005.5233
50 mm	65206.0005.5234
55 mm	65206.0005.5235
60 mm	65206.0005.5236
65 mm	65206.0005.5237
70 mm	65206.0005.5238
75 mm	65206.0005.5239

Standardlänge	Teilenummer
80 mm	65206.0005.5240
85 mm	65206.0005.5241
90 mm	65206.0005.5242
95 mm	65206.0005.5243
100 mm	65206.0005.5244
200 mm	65206.0005.5170
275 mm	65206.0005.5245
300 mm	65206.0005.5246
515 mm	65206.0005.5068
1030 mm	65206.0005.3024
550 FSW	65206.0005.9012
1000 FSC	65206.0005.0047
100 Horn	65206.0005.7042



F max = 700 kN/m



26.3 kg/m



P5 RF-A H175 R1.0

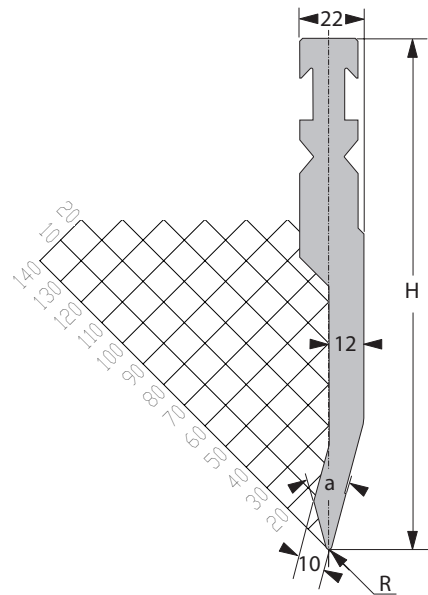
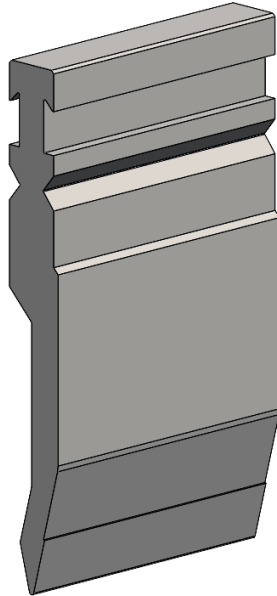

[R] Radius (mm)	1.0
Spitzenwinkel	30°
[H] Höhe (mm)	175

Bestell-Nr.	Vorderseite: 10170426
Datenblatt OTD	Rückseite: 10165692

Standardlänge	Teilenummer
10 mm	65206.0005.5103
15 mm	65206.0005.5151
20 mm	65206.0005.5147
25 mm	65206.0005.5194
30 mm	65206.0005.5152
35 mm	65206.0005.5195
40 mm	65206.0005.5198
45 mm	65206.0005.5196
50 mm	65206.0005.5153
55 mm	65206.0005.5199
60 mm	65206.0005.5197
65 mm	65206.0005.5200
70 mm	65206.0005.5201
75 mm	65206.0005.5202

Standardlänge	Teilenummer
80 mm	65206.0005.5203
85 mm	65206.0005.5204
90 mm	65206.0005.5205
95 mm	65206.0005.5206
100 mm	65206.0005.5085
200 mm	65206.0005.5104
275 mm	65206.0005.5110
300 mm	65206.0005.5105
515 mm	65206.0005.5007
1030 mm	65206.0005.3004
550 FSW	65206.0005.9001
1000 FSC	65206.0005.0003
100 Horn	65206.0005.7002

F_{max} = 1000 kN/m

19.0 kg/m



P5 RF-A H250 R1.0

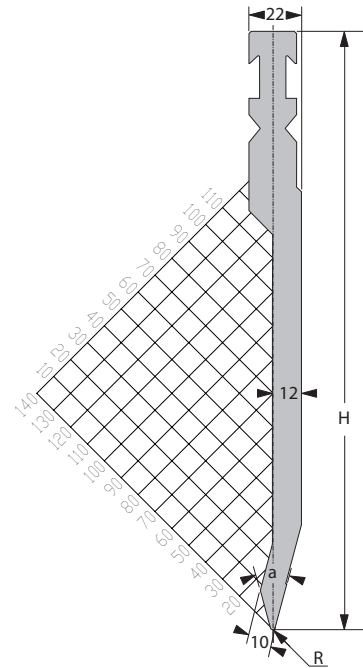
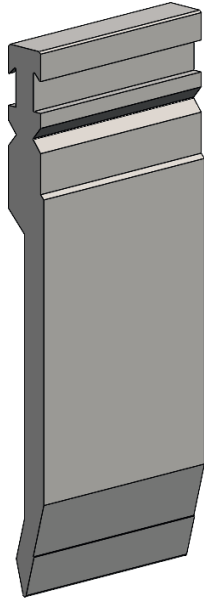

[R] Radius (mm)	1.0
Spitzenwinkel	30°
[H] Höhe (mm)	250

Bestell-Nr.	Vorderseite: 10170427
Datenblatt OTD	Rückseite: 10165693

Standardlänge	Teilenummer
10 mm	65206.0005.5012
15 mm	65206.0005.5087
20 mm	65206.0005.5155
25 mm	65206.0005.5096
30 mm	65206.0005.5097
35 mm	65206.0005.5093
40 mm	65206.0005.5094
45 mm	65206.0005.5095
50 mm	65206.0005.5088
55 mm	65206.0005.5121
60 mm	65206.0005.5164
65 mm	65206.0005.5111
70 mm	65206.0005.5165
75 mm	65206.0005.5122

Standardlänge	Teilenummer
80 mm	65206.0005.5123
85 mm	65206.0005.5124
90 mm	65206.0005.5125
95 mm	65206.0005.5126
100 mm	65206.0005.5044
200 mm	65206.0005.5078
275 mm	65206.0005.5209
300 mm	65206.0005.5027
515 mm	65206.0005.5008
1030 mm	65206.0005.3005
550 FSW	65206.0005.9002
1000 FSC	65206.0005.0004
100 Horn	65206.0005.7001



F max = 750 kN/m



26.0 kg/m



P5 RF-A H175 R1.5

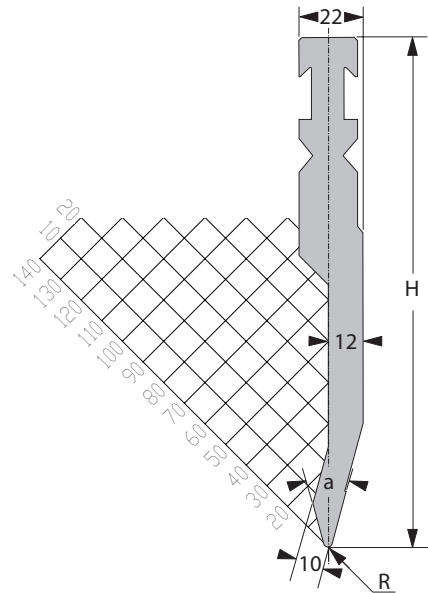
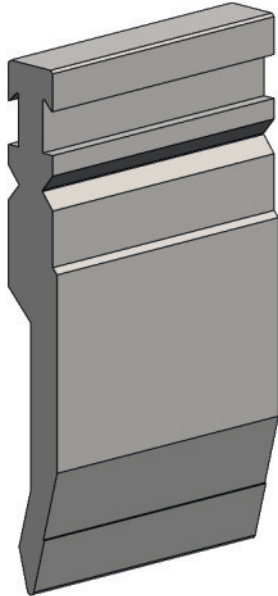

[R] Radius (mm)	1.5
Spitzenwinkel	30°
[H] Höhe (mm)	175

Bestell-Nr.	Vorderseite: 10170430
Datenblatt OTD	Rückseite: 10165696

Standardlänge	Teilenummer
10 mm	65206.0005.5247
15 mm	65206.0005.5248
20 mm	65206.0005.5249
25 mm	65206.0005.5250
30 mm	65206.0005.5251
35 mm	65206.0005.5252
40 mm	65206.0005.5253
45 mm	65206.0005.5254
50 mm	65206.0005.5255
55 mm	65206.0005.5256
60 mm	65206.0005.5257
65 mm	65206.0005.5258
70 mm	65206.0005.5259
75 mm	65206.0005.5260

Standardlänge	Teilenummer
80 mm	65206.0005.5261
85 mm	65206.0005.5262
90 mm	65206.0005.5263
95 mm	65206.0005.5264
100 mm	65206.0005.5265
200 mm	65206.0005.5266
275 mm	65206.0005.5267
300 mm	65206.0005.5268
515 mm	65206.0005.5042
1030 mm	65206.0005.3021
550 FSW	65206.0005.9031
1000 FSC	65206.0005.0024
100 Horn	65206.0005.7023

F_{max} = 1000 kN/m

19.0 kg/m



P5 RF-A H250 R1.5

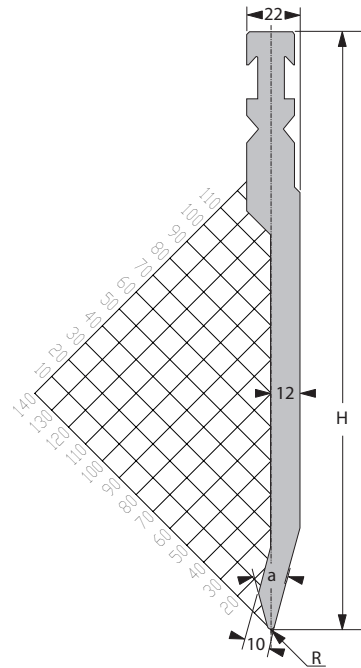
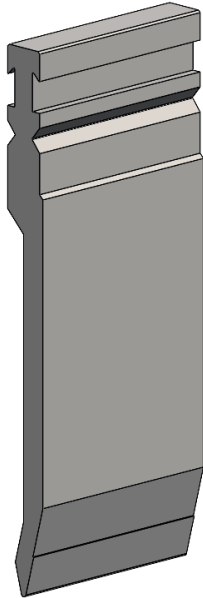

[R] Radius (mm)	1.5
Spitzenwinkel	30°
[H] Höhe (mm)	250

Bestell-Nr.	Vorderseite: 10170431
Datenblatt OTD	Rückseite: 10165697

Standardlänge	Teilenummer
10 mm	65206.0005.5269
15 mm	65206.0005.5270
20 mm	65206.0005.5271
25 mm	65206.0005.5272
30 mm	65206.0005.5273
35 mm	65206.0005.5274
40 mm	65206.0005.5275
45 mm	65206.0005.5276
50 mm	65206.0005.5277
55 mm	65206.0005.5278
60 mm	65206.0005.5279
65 mm	65206.0005.5280
70 mm	65206.0005.5281
75 mm	65206.0005.5282

Standardlänge	Teilenummer
80 mm	65206.0005.5283
85 mm	65206.0005.5284
90 mm	65206.0005.5285
95 mm	65206.0005.5286
100 mm	65206.0005.5287
200 mm	65206.0005.5288
275 mm	65206.0005.5289
300 mm	65206.0005.5290
515 mm	65206.0005.5009
1030 mm	65206.0005.3025
550 FSW	65206.0005.9022
1000 FSC	65206.0005.0015
100 Horn	65206.0005.7015



F max = 1000 kN/m



26.0 kg/m



P5 RF-A H175 R3.0

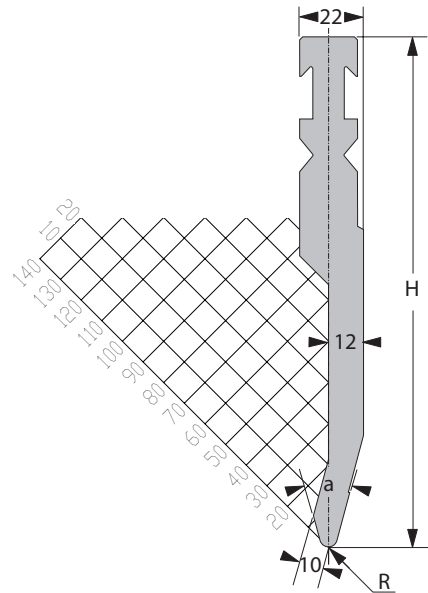
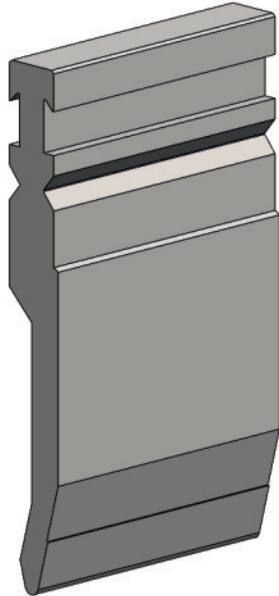

[R] Radius (mm)	3.0
Spitzenwinkel	30°
[H] Höhe (mm)	175

Bestell-Nr.	Vorderseite: 10170432
Datenblatt OTD	Rückseite: 10165698

Standardlänge	Teilenummer
10 mm	65206.0005.5291
15 mm	65206.0005.5292
20 mm	65206.0005.5293
25 mm	65206.0005.5294
30 mm	65206.0005.5295
35 mm	65206.0005.5296
40 mm	65206.0005.5297
45 mm	65206.0005.5298
50 mm	65206.0005.5299
55 mm	65206.0005.5300
60 mm	65206.0005.5301
65 mm	65206.0005.5302
70 mm	65206.0005.5303
75 mm	65206.0005.5304

Standardlänge	Teilenummer
80 mm	65206.0005.5305
85 mm	65206.0005.5306
90 mm	65206.0005.5307
95 mm	65206.0005.5308
100 mm	65206.0005.5180
200 mm	65206.0005.5309
275 mm	65206.0005.5310
300 mm	65206.0005.5311
515 mm	65206.0005.5014
1030 mm	65206.0005.3009
550 FSW	65206.0005.9010
1000 FSC	65206.0005.0013
100 Horn	65206.0005.7008



F max = 1000 kN/m



19.0 kg/m



P5 RF-A H250 R3.0

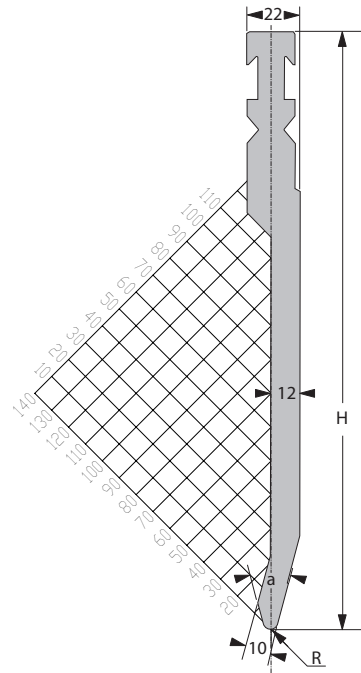
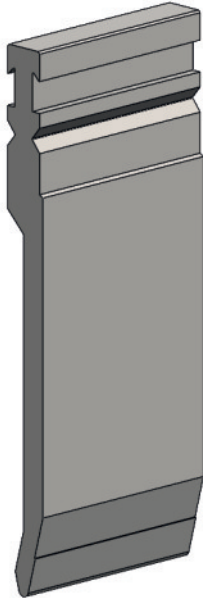

[R] Radius (mm)	3.0
Spitzenwinkel	30°
[H] Höhe (mm)	250

Bestell-Nr.	Vorderseite: 10170433
Datenblatt OTD	Rückseite: 10165699

Standardlänge	Teilenummer
10 mm	65206.0005.5312
15 mm	65206.0005.5313
20 mm	65206.0005.5314
25 mm	65206.0005.5315
30 mm	65206.0005.5316
35 mm	65206.0005.5317
40 mm	65206.0005.5318
45 mm	65206.0005.5319
50 mm	65206.0005.5320
55 mm	65206.0005.5321
60 mm	65206.0005.5322
65 mm	65206.0005.5323
70 mm	65206.0005.5324
75 mm	65206.0005.5325

Standardlänge	Teilenummer
80 mm	65206.0005.5326
85 mm	65206.0005.5327
90 mm	65206.0005.5328
95 mm	65206.0005.5329
100 mm	65206.0005.5083
200 mm	65206.0005.5090
275 mm	65206.0005.5330
300 mm	65206.0005.5084
515 mm	65206.0005.5018
1030 mm	65206.0005.3026
550 FSW	65206.0005.9014
1000 FSC	65206.0005.0020
100 Horn	65206.0005.7019



F max = 1000 kN/m



26.1 kg/m



P6 RF-A H175 R1.0

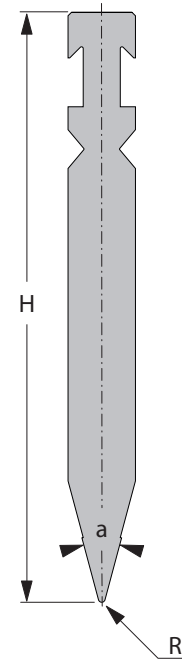
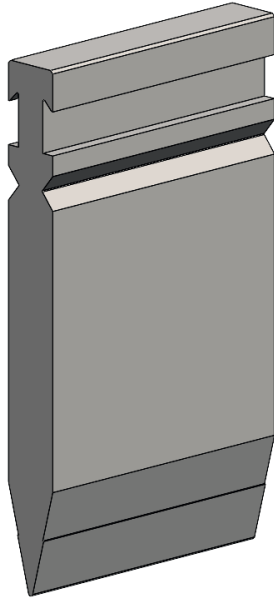

[R] Radius (mm)	1.0
Spitzenwinkel	30°
[H] Höhe (mm)	175

Bestell-Nr. Datenblatt OTD: 10165700

Standardlänge	Teilenummer
10 mm	65206.0006.5045
15 mm	65206.0006.5046
20 mm	65206.0006.5047
25 mm	65206.0006.5048
30 mm	65206.0006.5049
35 mm	65206.0006.5050
40 mm	65206.0006.5051
45 mm	65206.0006.5052
50 mm	65206.0006.5053
55 mm	65206.0006.5054
60 mm	65206.0006.5055
65 mm	65206.0006.5056
70 mm	65206.0006.5057
75 mm	65206.0006.5058

Standardlänge	Teilenummer
80 mm	65206.0006.5059
85 mm	65206.0006.5060
90 mm	65206.0006.5061
95 mm	65206.0006.5062
100 mm	65206.0006.5063
200 mm	65206.0006.5064
275 mm	65206.0006.5065
300 mm	65206.0006.5066
515 mm	65206.0006.5001
1030 mm	65206.0006.3003
550 FSW	65206.0006.9001
1000 FSC	65206.0006.0001
100 Horn	65203.0006.7002



F max = 1500 kN/m



23.3 kg/m



P6 RF-A H250 R1.0

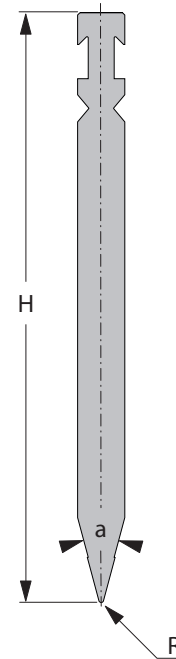
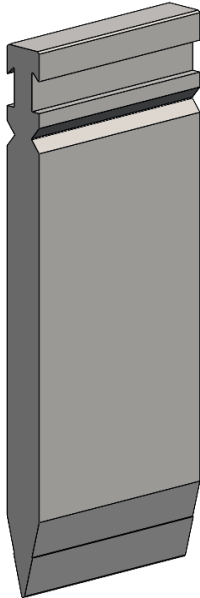

[R] Radius (mm)	1.0
Spitzenwinkel	30°
[H] Höhe (mm)	250

Bestell-Nr. Datenblatt OTD: 10165701

Standardlänge	Teilenummer
10 mm	65206.0006.5067
15 mm	65206.0006.5068
20 mm	65206.0006.5026
25 mm	65206.0006.5027
30 mm	65206.0006.5021
35 mm	65206.0006.5028
40 mm	65206.0006.5029
45 mm	65206.0006.5030
50 mm	65206.0006.5031
55 mm	65206.0006.5032
60 mm	65206.0006.5033
65 mm	65206.0006.5034
70 mm	65206.0006.5035
75 mm	65206.0006.5036

Standardlänge	Teilenummer
80 mm	65206.0006.5037
85 mm	65206.0006.5038
90 mm	65206.0006.5039
95 mm	65206.0006.5040
100 mm	65206.0006.5016
200 mm	65206.0006.5041
275 mm	65206.0006.5069
300 mm	65206.0006.5042
515 mm	65206.0006.5002
1030 mm	65206.0006.3002
550 FSW	65206.0006.9002
1000 FSC	65206.0006.0002
100 Horn	65206.0006.7001



F max = 1500 kN/m



35.0 kg/m



P7 RF-A H175 R3.0

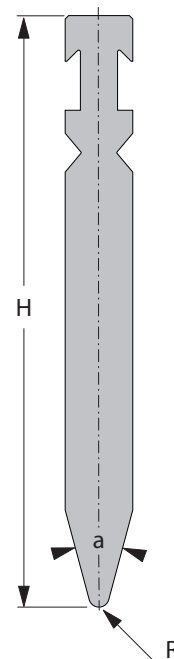
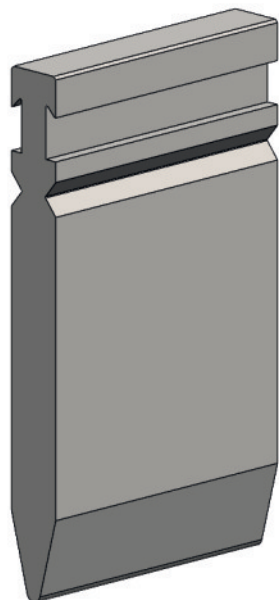

[R] Radius (mm)	3.0
Spitzenwinkel	30°
[H] Höhe (mm)	175

Bestell-Nr. Datenblatt OTD: 10165702

Standardlänge	Teilenummer
10 mm	65206.0007.5157
15 mm	65206.0007.5083
20 mm	65206.0007.5080
25 mm	65206.0007.5158
30 mm	65206.0007.5081
35 mm	65206.0007.5159
40 mm	65206.0007.5160
45 mm	65206.0007.5161
50 mm	65206.0007.5084
55 mm	65206.0007.5162
60 mm	65206.0007.5163
65 mm	65206.0007.5164
70 mm	65206.0007.5165
75 mm	65206.0007.5166

Standardlänge	Teilenummer
80 mm	65206.0007.5167
85 mm	65206.0007.5168
90 mm	65206.0007.5169
95 mm	65206.0007.5170
100 mm	65206.0007.5082
200 mm	65206.0007.5103
275 mm	65206.0007.5171
300 mm	65206.0007.5172
515 mm	65206.0007.5002
1030 mm	65206.0007.3004
550 FSW	65206.0007.9001
1000 FSC	65206.0007.0003
100 Horn	65206.0007.7001



F max = 1600 kN/m



24.2 kg/m



P7 RF-A H250 R3.0

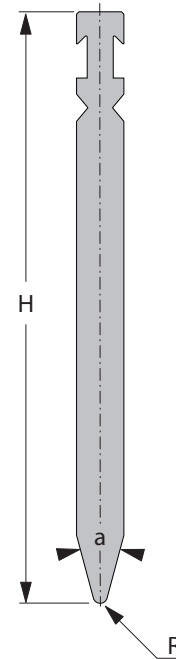
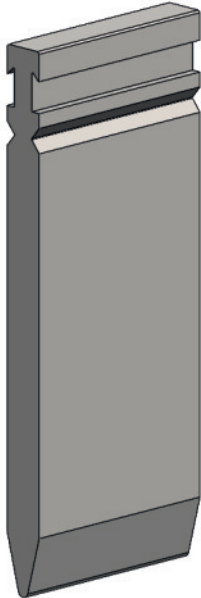

[R] Radius (mm)	3.0
Spitzenwinkel	30°
[H] Höhe (mm)	250

Bestell-Nr. Datenblatt OTD: 10165704

Standardlänge	Teilenummer
10 mm	65206.0007.5091
15 mm	65206.0007.5119
20 mm	65206.0007.5120
25 mm	65206.0007.5121
30 mm	65206.0007.5137
35 mm	65206.0007.5173
40 mm	65206.0007.5174
45 mm	65206.0007.5175
50 mm	65206.0007.5109
55 mm	65206.0007.5176
60 mm	65206.0007.5177
65 mm	65206.0007.5178
70 mm	65206.0007.5179
75 mm	65206.0007.5180

Standardlänge	Teilenummer
80 mm	65206.0007.5181
85 mm	65206.0007.5182
90 mm	65206.0007.5183
95 mm	65206.0007.5184
100 mm	65206.0007.5078
200 mm	65206.0007.5092
275 mm	65206.0007.5185
300 mm	65206.0007.5030
515 mm	65206.0007.5003
1030 mm	65206.0007.3006
550 FSW	65206.0007.9002
1000 FSC	65206.0007.0002
100 Horn	65206.0007.7002



F_{max} = 1600 kN/m



36.0 kg/m



P7 RF-A H175 R5.0

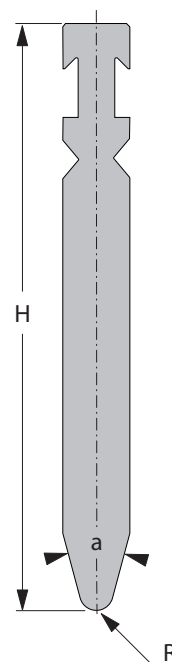
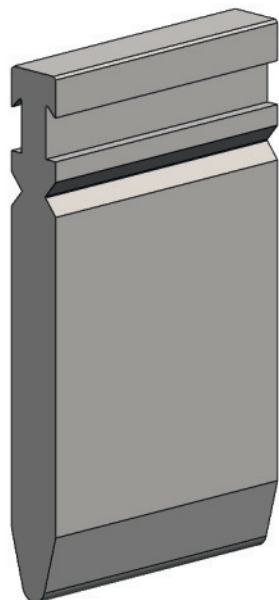

[R] Radius (mm)	5.0
Spitzenwinkel	30°
[H] Höhe (mm)	175

Bestell-Nr. Datenblatt OTD: 10165704

Standardlänge	Teilenummer
10 mm	65206.0007.5186
15 mm	65206.0007.5187
20 mm	65206.0007.5188
25 mm	65206.0007.5189
30 mm	65206.0007.5190
35 mm	65206.0007.5191
40 mm	65206.0007.5192
45 mm	65206.0007.5193
50 mm	65206.0007.5194
55 mm	65206.0007.5195
60 mm	65206.0007.5196
65 mm	65206.0007.5197
70 mm	65206.0007.5198
75 mm	65206.0007.5199

Standardlänge	Teilenummer
80 mm	65206.0007.5200
85 mm	65206.0007.5201
90 mm	65206.0007.5202
95 mm	65206.0007.5203
100 mm	65206.0007.5079
200 mm	65206.0007.5072
275 mm	65206.0007.5204
300 mm	65206.0007.5205
515 mm	65206.0007.5008
1030 mm	65206.0007.3008
550 FSW	65206.0007.9004
1000 FSC	65206.0007.0012
100 Horn	65206.0007.7026



F max = 1600 kN/m



27.0 kg/m



P7 RF-A H250 R5.0

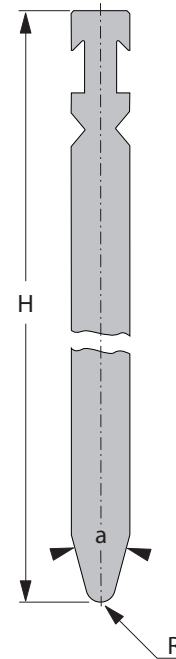
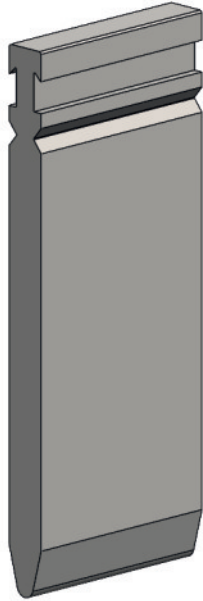

[R] Radius (mm)	5.0
Spitzenwinkel	30°
[H] Höhe (mm)	250

Bestell-Nr. Datenblatt OTD: 10165711

Standardlänge	Teilenummer
10 mm	65206.0007.5206
15 mm	65206.0007.5207
20 mm	65206.0007.5208
25 mm	65206.0007.5209
30 mm	65206.0007.5210
35 mm	65206.0007.5211
40 mm	65206.0007.5212
45 mm	65206.0007.5213
50 mm	65206.0007.5214
55 mm	65206.0007.5215
60 mm	65206.0007.5216
65 mm	65206.0007.5217
70 mm	65206.0007.5218
75 mm	65206.0007.5219

Standardlänge	Teilenummer
80 mm	65206.0007.5220
85 mm	65206.0007.5221
90 mm	65206.0007.5222
95 mm	65206.0007.5223
100 mm	65206.0007.5224
200 mm	65206.0007.5089
275 mm	65206.0007.5225
300 mm	65206.0007.5226
515 mm	65206.0007.5004
1030 mm	65206.0007.3005
550 FSW	65206.0007.9008
1000 FSC	65206.0007.0015
100 Horn	65206.0007.7013



F max = 1400 kN/m



37.0 kg/m



P7 RF-A H175 R6.0

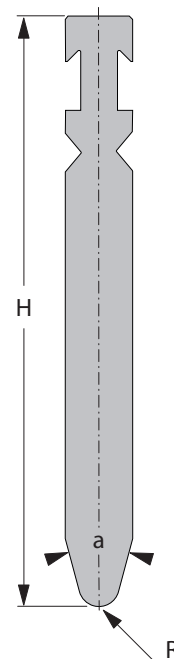
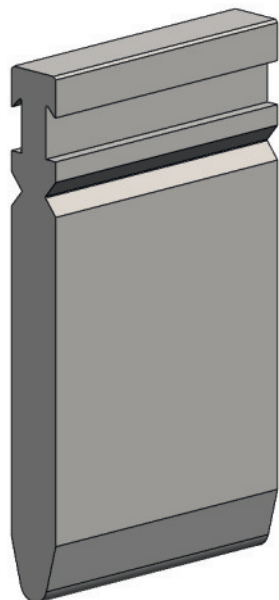

[R] Radius (mm)	6.0
Spitzenwinkel	30°
[H] Höhe (mm)	175

Bestell-Nr. Datenblatt OTD: 10165713

Standardlänge	Teilenummer
10 mm	65206.0007.5227
15 mm	65206.0007.5228
20 mm	65206.0007.5229
25 mm	65206.0007.5230
30 mm	65206.0007.5231
35 mm	65206.0007.5232
40 mm	65206.0007.5233
45 mm	65206.0007.5234
50 mm	65206.0007.5235
55 mm	65206.0007.5236
60 mm	65206.0007.5237
65 mm	65206.0007.5238
70 mm	65206.0007.5239
75 mm	65206.0007.5240

Standardlänge	Teilenummer
80 mm	65206.0007.5241
85 mm	65206.0007.5242
90 mm	65206.0007.5243
95 mm	65206.0007.5244
100 mm	65206.0007.5245
200 mm	65206.0007.5246
275 mm	65206.0007.5247
300 mm	65206.0007.5248
515 mm	65206.0007.5019
1030 mm	65206.0007.3009
550 FSW	65206.0007.9006
1000 FSC	65206.0007.0014
100 Horn	65206.0007.7017



F max = 1600 kN/m



25.7 kg/m



P7 RF-A H250 R6.0

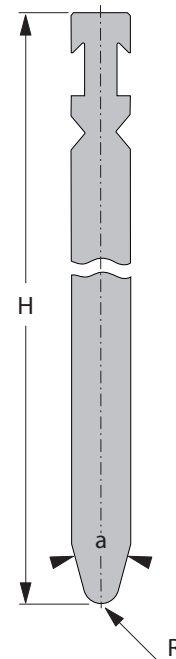
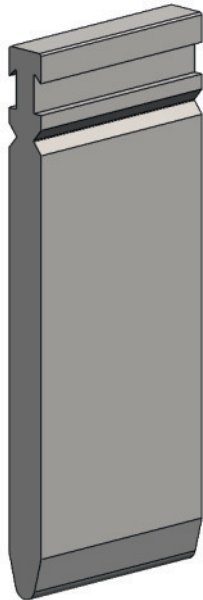

[R] Radius (mm)	6.0
Spitzenwinkel	30°
[H] Höhe (mm)	250

Bestell-Nr. Datenblatt OTD: 10165714

Standardlänge	Teilenummer
10 mm	65206.0007.5249
15 mm	65206.0007.5250
20 mm	65206.0007.5251
25 mm	65206.0007.5252
30 mm	65206.0007.5253
35 mm	65206.0007.5254
40 mm	65206.0007.5255
45 mm	65206.0007.5256
50 mm	65206.0007.5094
55 mm	65206.0007.5257
60 mm	65206.0007.5258
65 mm	65206.0007.5259
70 mm	65206.0007.5260
75 mm	65206.0007.5261

Standardlänge	Teilenummer
80 mm	65206.0007.5262
85 mm	65206.0007.5263
90 mm	65206.0007.5264
95 mm	65206.0007.5265
100 mm	65206.0007.5093
200 mm	65206.0007.5130
275 mm	65206.0007.5266
300 mm	65206.0007.5129
515 mm	65206.0007.5007
1030 mm	65206.0007.3013
550 FSW	65206.0007.9009
1000 FSC	65206.0007.0005
100 Horn	65206.0007.7003



F_{max} = 1400 kN/m



37.5 kg/m



P7 RF-A H175 R8.0

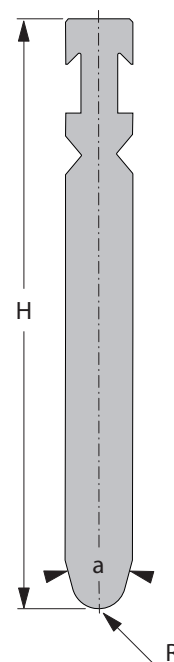
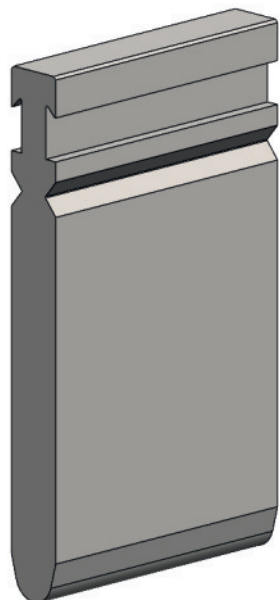

[R] Radius (mm)	8.0
Spitzenwinkel	30°
[H] Höhe (mm)	175

Bestell-Nr. Datenblatt OTD: 10165716

Standardlänge	Teilenummer
10 mm	65206.0007.5267
15 mm	65206.0007.5268
20 mm	65206.0007.5269
25 mm	65206.0007.5270
30 mm	65206.0007.5271
35 mm	65206.0007.5272
40 mm	65206.0007.5273
45 mm	65206.0007.5274
50 mm	65206.0007.5275
55 mm	65206.0007.5276
60 mm	65206.0007.5277
65 mm	65206.0007.5278
70 mm	65206.0007.5279
75 mm	65206.0007.5280

Standardlänge	Teilenummer
80 mm	65206.0007.5281
85 mm	65206.0007.5282
90 mm	65206.0007.5283
95 mm	65206.0007.5284
100 mm	65206.0007.5285
200 mm	65206.0007.5286
275 mm	65206.0007.5287
300 mm	65206.0007.5288
515 mm	65206.0007.5020
1030 mm	65206.0007.3014
550 FSW	65206.0007.9014
1000 FSC	65206.0007.0039
100 Horn	65206.0007.7004



F max = 1600 kN/m



26.0 kg/m



P7 RF-A H250 R8.0

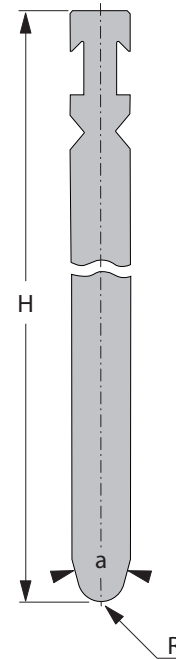
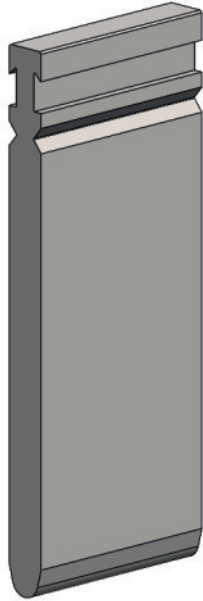

[R] Radius (mm)	8.0
Spitzenwinkel	30°
[H] Höhe (mm)	250

Bestell-Nr. Datenblatt OTD: 10165717

Standardlänge	Teilenummer
10 mm	65206.0007.5289
15 mm	65206.0007.5290
20 mm	65206.0007.5291
25 mm	65206.0007.5292
30 mm	65206.0007.5293
35 mm	65206.0007.5294
40 mm	65206.0007.5295
45 mm	65206.0007.5296
50 mm	65206.0007.5085
55 mm	65206.0007.5297
60 mm	65206.0007.5298
65 mm	65206.0007.5299
70 mm	65206.0007.5300
75 mm	65206.0007.5301

Standardlänge	Teilenummer
80 mm	65206.0007.5302
85 mm	65206.0007.5303
90 mm	65206.0007.5304
95 mm	65206.0007.5305
100 mm	65206.0007.5134
200 mm	65206.0007.5133
275 mm	65206.0007.5306
300 mm	65206.0007.5132
515 mm	65206.0007.5014
1030 mm	65206.0007.3015
550 FSW	65206.0007.9016
1000 FSC	65206.0007.0032
100 Horn	65206.0007.7014



F max = 1400 kN/m



37.6 kg/m



P7 RF-A H175 R10.0

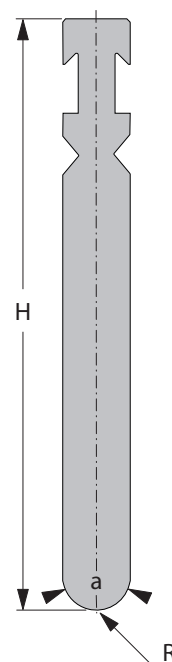
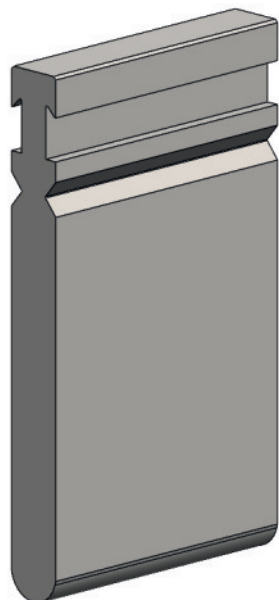

[R] Radius (mm)	10.0
Spitzenwinkel	30°
[H] Höhe (mm)	175

Bestell-Nr. Datenblatt OTD: 10165718

Standardlänge	Teilenummer
10 mm	65206.0007.5307
15 mm	65206.0007.5308
20 mm	65206.0007.5309
25 mm	65206.0007.5310
30 mm	65206.0007.5311
35 mm	65206.0007.5312
40 mm	65206.0007.5313
45 mm	65206.0007.5314
50 mm	65206.0007.5315
55 mm	65206.0007.5316
60 mm	65206.0007.5317
65 mm	65206.0007.5318
70 mm	65206.0007.5319
75 mm	65206.0007.5320

Standardlänge	Teilenummer
80 mm	65206.0007.5321
85 mm	65206.0007.5322
90 mm	65206.0007.5323
95 mm	65206.0007.5324
100 mm	65206.0007.5325
200 mm	65206.0007.5108
275 mm	65206.0007.5326
300 mm	65206.0007.5086
515 mm	65206.0007.5101
1030 mm	65206.0007.3011
550 FSW	65206.0007.9019
1000 FSC	65206.0007.0019
100 Horn	65206.0007.7029

F_{max} = 1600 kN/m

24.2 kg/m



P7 RF-A H250 R10.0

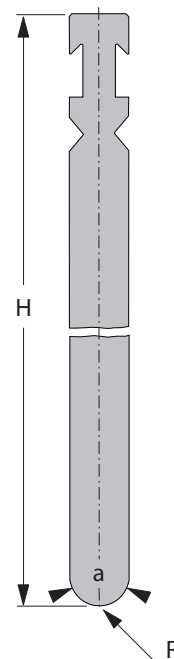
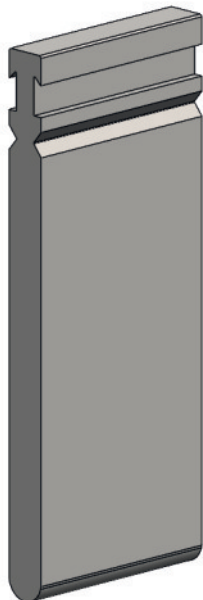

[R] Radius (mm)	10.0
Spitzenwinkel	30°
[H] Höhe (mm)	250

Bestell-Nr. Datenblatt OTD: 10165719

Standardlänge	Teilenummer
10 mm	65206.0007.5327
15 mm	65206.0007.5328
20 mm	65206.0007.5329
25 mm	65206.0007.5330
30 mm	65206.0007.5331
35 mm	65206.0007.5332
40 mm	65206.0007.5333
45 mm	65206.0007.5334
50 mm	65206.0007.5141
55 mm	65206.0007.5335
60 mm	65206.0007.5336
65 mm	65206.0007.5337
70 mm	65206.0007.5338
75 mm	65206.0007.5339

Standardlänge	Teilenummer
80 mm	65206.0007.5340
85 mm	65206.0007.5341
90 mm	65206.0007.5342
95 mm	65206.0007.5343
100 mm	65206.0007.5140
200 mm	65206.0007.5344
275 mm	65206.0007.5345
300 mm	65206.0007.5146
515 mm	65206.0007.5040
1030 mm	65206.0007.3016
550 FSW	65206.0007.9020
1000 FSC	65206.0007.0036
100 Horn	65206.0007.7021



F_{max} = 1600 kN/m



38.0 kg/m



P7 RF-A H175 R12.0

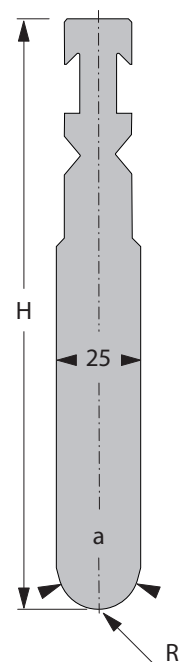
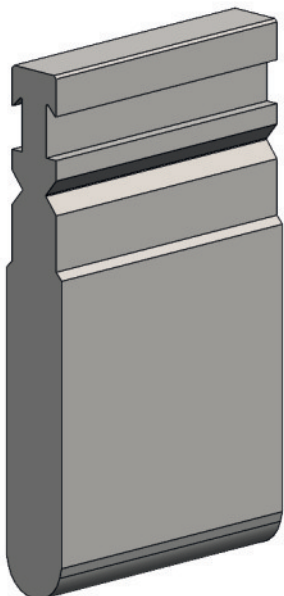

[R] Radius (mm)	12.0
Spitzenwinkel	30°
[H] Höhe (mm)	175

Bestell-Nr. Datenblatt OTD: 10165720

Standardlänge	Teilenummer
10 mm	65206.0007.5346
15 mm	65206.0007.5347
20 mm	65206.0007.5348
25 mm	65206.0007.5349
30 mm	65206.0007.5350
35 mm	65206.0007.5351
40 mm	65206.0007.5352
45 mm	65206.0007.5353
50 mm	65206.0007.5354
55 mm	65206.0007.5355
60 mm	65206.0007.5356
65 mm	65206.0007.5357
70 mm	65206.0007.5358
75 mm	65206.0007.5359

Standardlänge	Teilenummer
80 mm	65206.0007.5360
85 mm	65206.0007.5361
90 mm	65206.0007.5362
95 mm	65206.0007.5363
100 mm	65206.0007.5364
200 mm	65206.0007.5365
275 mm	65206.0007.5366
300 mm	65206.0007.5076
515 mm	65206.0007.5046
1030 mm	65206.0007.3017
550 FSW	65206.0007.9021
1000 FSC	65206.0007.0053
100 Horn	65206.0007.7038

F_{max} = 1600 kN/m

30.4 kg/m



P7 RF-A H250 R12.0

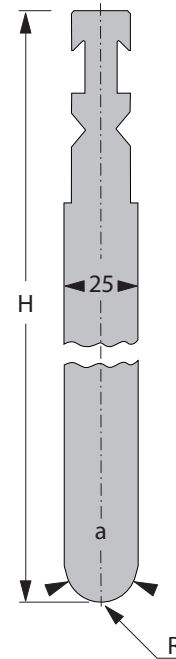
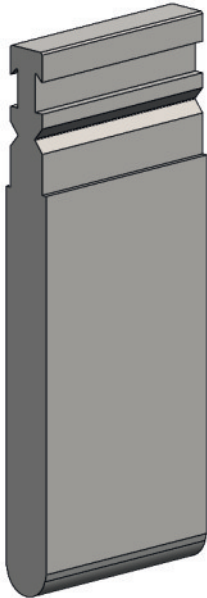

[R] Radius (mm)	12.0
Spitzenwinkel	30°
[H] Höhe (mm)	250

Bestell-Nr. Datenblatt OTD: 10165721

Standardlänge	Teilenummer
10 mm	65206.0007.5367
15 mm	65206.0007.5368
20 mm	65206.0007.5369
25 mm	65206.0007.5370
30 mm	65206.0007.5371
35 mm	65206.0007.5372
40 mm	65206.0007.5373
45 mm	65206.0007.5374
50 mm	65206.0007.5375
55 mm	65206.0007.5376
60 mm	65206.0007.5377
65 mm	65206.0007.5378
70 mm	65206.0007.5379
75 mm	65206.0007.5380

Standardlänge	Teilenummer
80 mm	65206.0007.5381
85 mm	65206.0007.5382
90 mm	65206.0007.5383
95 mm	65206.0007.5384
100 mm	65206.0007.5385
200 mm	65206.0007.5386
275 mm	65206.0007.5387
300 mm	65206.0007.5388
515 mm	65206.0007.5138
1030 mm	65206.0007.3018
550 FSW	65206.0007.9022
1000 FSC	65206.0007.0050
100 Horn	65206.0007.7039



F max = 1600 kN/m



44.5 kg/m



P8 RF-A H175 R1.0

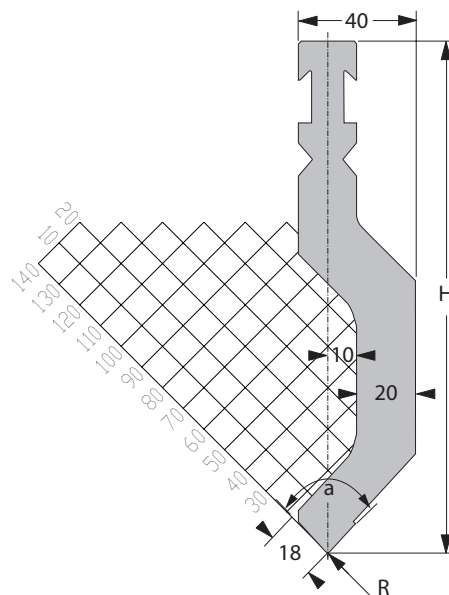
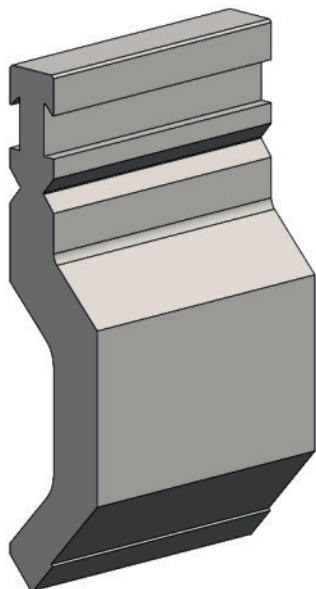

[R] Radius (mm)	1.0
Spitzenwinkel	85°
[H] Höhe (mm)	175

Bestell-Nr.	Vorderseite: 10170357
Datenblatt OTD	Rückseite: 10165722

Standardlänge	Teilenummer
10 mm	65206.0008.5062
15 mm	65206.0008.5063
20 mm	65206.0008.5064
25 mm	65206.0008.5065
30 mm	65206.0008.5066
35 mm	65206.0008.5067
40 mm	65206.0008.5068
45 mm	65206.0008.5069
50 mm	65206.0008.5070
55 mm	65206.0008.5071
60 mm	65206.0008.5072
65 mm	65206.0008.5073
70 mm	65206.0008.5074
75 mm	65206.0008.5075

Standardlänge	Teilenummer
80 mm	65206.0008.5076
85 mm	65206.0008.5077
90 mm	65206.0008.5078
95 mm	65206.0008.5079
100 mm	65206.0008.5080
200 mm	65206.0008.5041
275 mm	65206.0008.5081
300 mm	65206.0008.5082
515 mm	65206.0008.5002
1030 mm	65206.0008.3003
550 FSW	65206.0008.9001
1000 FSC	65206.0008.0001
100 Horn	65206.0008.7001



F max = 1000 kN/m



27.2 kg/m



P8 RF-A H250 R1.0

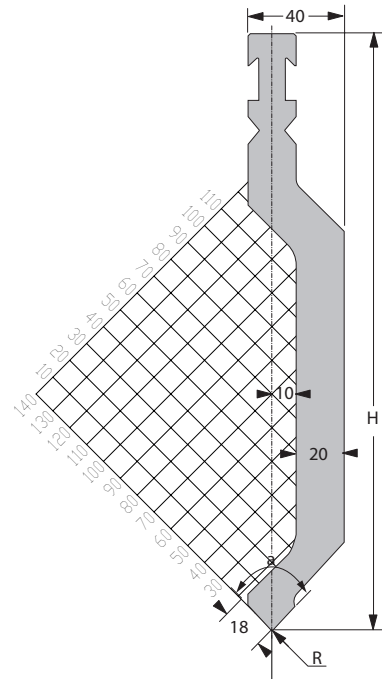
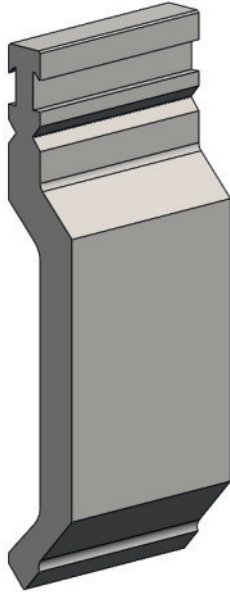

[R] Radius (mm)*	1.0
Spitzenwinkel	85°
[H] Höhe (mm)	250

Bestell-Nr.	Vorderseite: 10170409
Datenblatt OTD	Rückseite: 10165723

Standardlänge	Teilenummer
10 mm	65206.0008.5034
15 mm	65206.0008.5035
20 mm	65206.0008.5036
25 mm	65206.0008.5045
30 mm	65206.0008.5083
35 mm	65206.0008.5084
40 mm	65206.0008.5046
45 mm	65206.0008.5047
50 mm	65206.0008.5048
55 mm	65206.0008.5049
60 mm	65206.0008.5050
65 mm	65206.0008.5051
70 mm	65206.0008.5052
75 mm	65206.0008.5053

Standardlänge	Teilenummer
80 mm	65206.0008.5054
85 mm	65206.0008.5055
90 mm	65206.0008.5056
95 mm	65206.0008.5057
100 mm	65206.0008.5058
200 mm	65206.0008.5085
275 mm	65206.0008.5086
300 mm	65206.0008.5059
515 mm	65206.0008.5013
1030 mm	65206.0008.3004
550 FSW	65206.0008.9002
1000 FSC	65206.0008.0004
100 Horn	65206.0008.7002



F max = 1000 kN/m



38.3 kg/m



P9 RF-A H175 R4.0

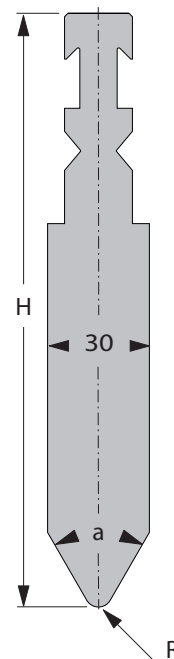
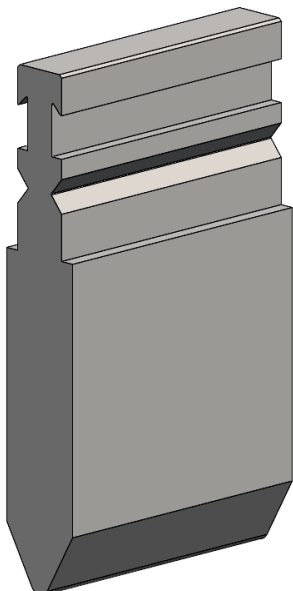

[R] Radius (mm)	4.0
Spitzenwinkel	60°
[H] Höhe (mm)	175

Bestell-Nr. Datenblatt OTD: 10165724

Standardlänge	Teilenummer
10 mm	65206.0009.5161
15 mm	65206.0009.5162
20 mm	65206.0009.5163
25 mm	65206.0009.5164
30 mm	65206.0009.5047
35 mm	65206.0009.5165
40 mm	65206.0009.5166
45 mm	65206.0009.5167
50 mm	65206.0009.5168
55 mm	65206.0009.5169
60 mm	65206.0009.5170
65 mm	65206.0009.5171
70 mm	65206.0009.5172
75 mm	65206.0009.5173

Standardlänge	Teilenummer
80 mm	65206.0009.5174
85 mm	65206.0009.5175
90 mm	65206.0009.5176
95 mm	65206.0009.5177
100 mm	65206.0009.5046
200 mm	65206.0009.5043
275 mm	65206.0009.5178
300 mm	65206.0009.5038
515 mm	65206.0009.5006
1030 mm	65206.0009.3003
550 FSW	65206.0009.9001
1000 FSC	65206.0009.0001
100 Horn	65206.0009.7001

F_{max} = 2000 kN/m

33.5 kg/m



P9 RF-A H250 R4.0

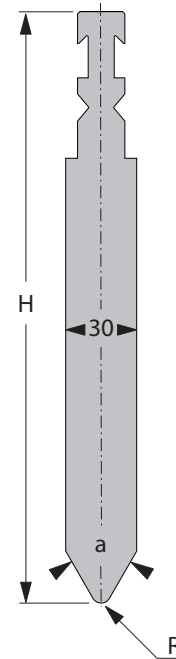
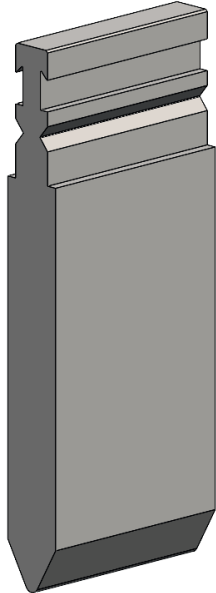

[R] Radius (mm)*	4.0
Spitzenwinkel	60°
[H] Höhe (mm)	250

Bestell-Nr. Datenblatt OTD: 10165725

Standardlänge	Teilenummer
10 mm	65206.0009.5179
15 mm	65206.0009.5180
20 mm	65206.0009.5181
25 mm	65206.0009.5182
30 mm	65206.0009.5183
35 mm	65206.0009.5184
40 mm	65206.0009.5089
45 mm	65206.0009.5090
50 mm	65206.0009.5091
55 mm	65206.0009.5092
60 mm	65206.0009.5093
65 mm	65206.0009.5094
70 mm	65206.0009.5095
75 mm	65206.0009.5096

Standardlänge	Teilenummer
80 mm	65206.0009.5097
85 mm	65206.0009.5098
90 mm	65206.0009.5099
95 mm	65206.0009.5100
100 mm	65206.0009.5101
200 mm	65206.0009.5065
275 mm	65206.0009.5185
300 mm	65206.0009.5102
515 mm	65206.0009.5005
1030 mm	65206.0009.3004
550 FSW	65206.0009.9002
1000 FSC	65206.0009.0002
100 Horn	65206.0009.7002



F max = 2000 kN/m



51.0 kg/m



P10 RF-A H150 B20

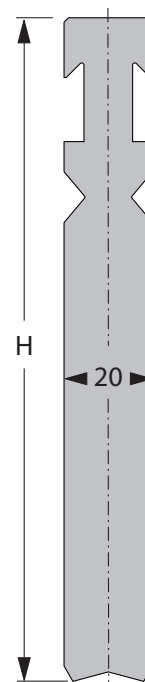
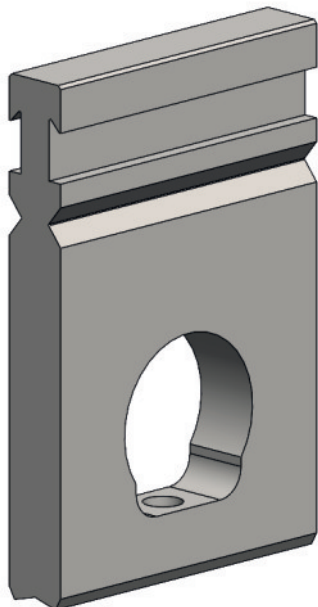

[R] Radius (mm)	-
Spitzenwinkel	-
[H] Höhe (mm)	150

Bestell-Nr. Datenblatt OTD: 10165727

Standardlänge	Teilenummer
515 mm	65206.0010.5003
1030 mm	65206.0010.3007



F max = 1200 kN/m



17.0 kg/m



P10 RF-A H250 B20

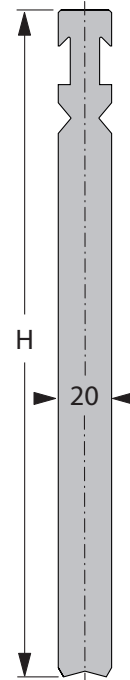
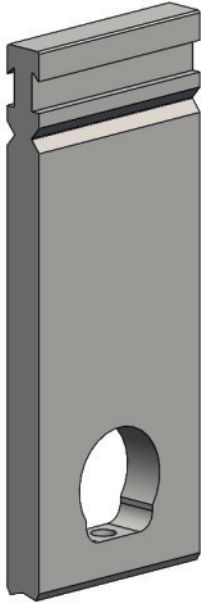

[R] Radius (mm)	-
Spitzenwinkel	-
[H] Höhe (mm)	250

Bestell-Nr. Datenblatt OTD: 10165729

Standardlänge	Teilenummer
515 mm	65206.0010.5016
1030 mm	65206.0010.3006



F max = 1200 kN/m



32.0 kg/m



P10 RF-A H150 B40

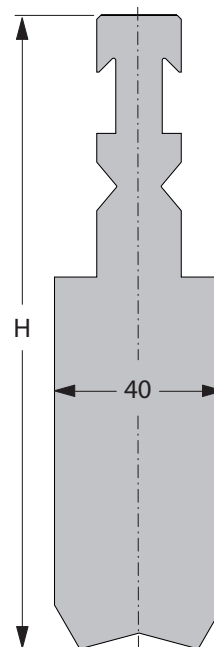
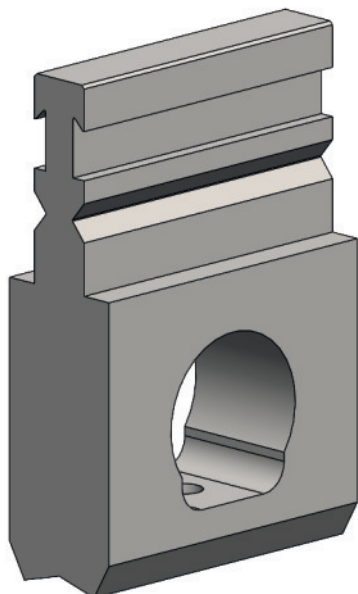

[R] Radius (mm)	-
Spitzenwinkel	-
[H] Höhe (mm)	150

Bestell-Nr. Datenblatt OTD: 10165726

Standardlänge	Teilenummer
515 mm	65206.0010.5004
1030 mm	65206.0010.3004



F max = 1600 kN/m



34.0 kg/m



P10 RF-A H250 B40

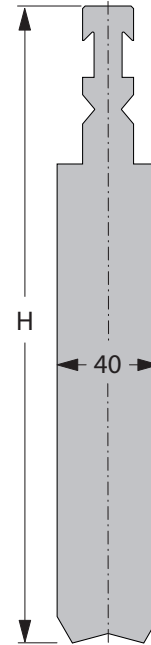
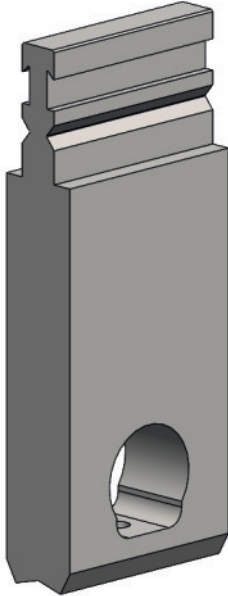

[R] Radius (mm)	-
Spitzenwinkel	-
[H] Höhe (mm)	250

Bestell-Nr. Datenblatt OTD: 10165728

Standardlänge	Teilenummer
515 mm	65206.0010.5005
1030 mm	65206.0010.3003



F max = 1600 kN/m



65.0 kg/m



P10 RF-A B20 Radiusstäbe

Rundstäbe geeignet für Radiusstabhalter

L	515/1030	515/1030	515/1030
Art	PB 16	PB 20	PB 24
Ø mm	16	20	24
Gewicht [kg]	2	3	4

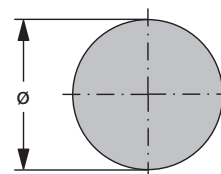

Standardlänge	Ø Rundstäbe	Teilenummer
515 mm	16 mm	65200.0016.5004
	20 mm	65200.0020.5020
	24 mm	65200.0024.5005
1030 mm	16 mm	65200.0016.3002
	20 mm	65200.0020.3008
	24 mm	65200.0024.3002



P10 RF-A B40 Radiusstäbe

Rundstäbe geeignet für Radiusstabhalter

L	515/1030	515/1030	515/1030	515/1030	515/1030	515/1030	515/1030
Art	PB 28	PB 30	PB 35	PB 40	PB 45	PB 50	PB 55
Ø mm	28	30	35	40	45	50	55
Gewicht [kg]	5	5.5	7.5	10	12.5	15.5	18.5

L	515/1030	515/1030	515/1030	515/1030
Art	PB 60	PB 65	PB 70	PB 80
Ø mm	60	65	70	80
Gewicht [kg]	22	26	30	39.5

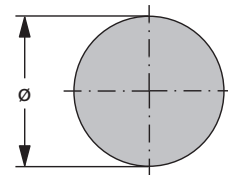

Standardlänge	Ø Rundstäbe	Teilenummer
515 mm	28 mm	65200.0028.5002
	30 mm	65200.0030.5007
	35 mm	65200.0035.5005
	40 mm	65200.0040.5005
	45 mm	65200.0045.5003
	50 mm	65200.0050.5009
	55 mm	65200.0055.5002
	60 mm	65200.0060.5004
	65 mm	65200.0065.5002
	70 mm	65200.0070.5001
	80 mm	65200.0080.5003
1030 mm	28 mm	65200.0028.3002
	30 mm	65200.0030.3007
	35 mm	65200.0035.3002
	40 mm	65200.0040.3006
	45 mm	65200.0045.3002
	50 mm	65200.0050.3005
	55 mm	65200.0055.3001
	60 mm	65200.0060.3004
	65 mm	65200.0065.3001
	70 mm	65200.0070.3003
	80 mm	65200.0080.3004



P12 RF-A H130

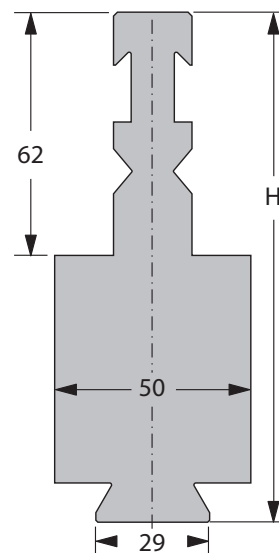
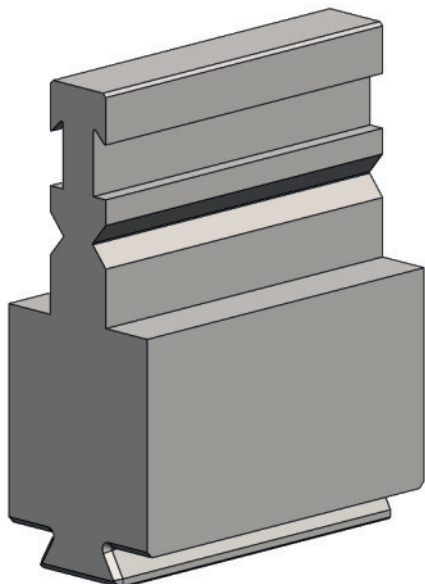

[R] Radius (mm)	-
Spitzenwinkel	-
[H] Höhe (mm)	130

Bestell-Nr. Datenblatt OTD: 10165730

Standardlänge	Teilenummer
515 mm	65206.0012.5001
550 FSW	65206.0012.9001
1000 FSC	65206.0012.0002



F max = 1600 kN/m



33.0 kg/m



P12 RF-A H206

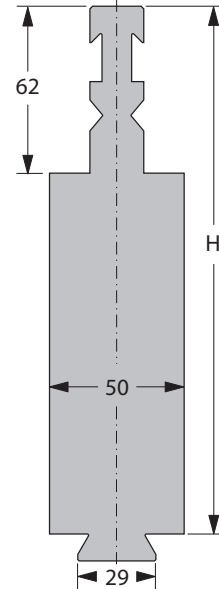
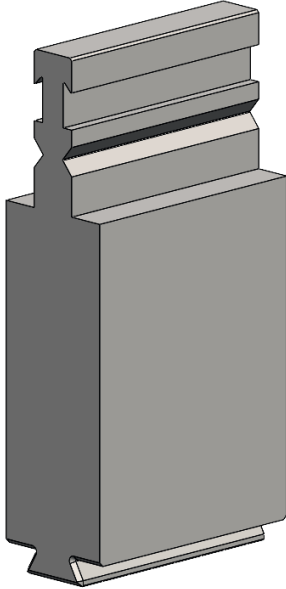

[R] Radius (mm)	-
Spitzenwinkel	-
[H] Höhe (mm)	206

Bestell-Nr. Datenblatt OTD: 10165731

Standardlänge	Teilenummer
515 mm	65206.0012.5003
550 FSW	65206.0012.9002
1000 FSC	65206.0012.0001



F max = 1600 kN/m



63.0 kg/m



P12 Radiuswerkzeuge

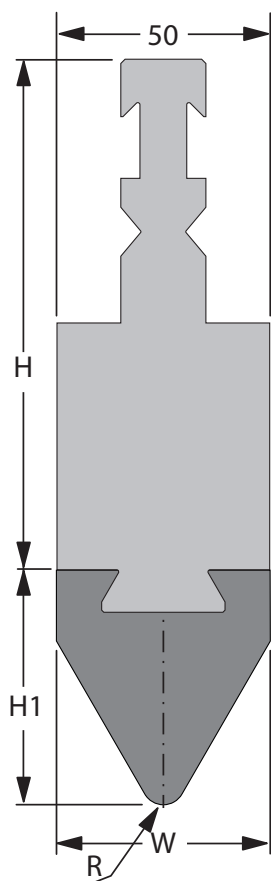

Typ A

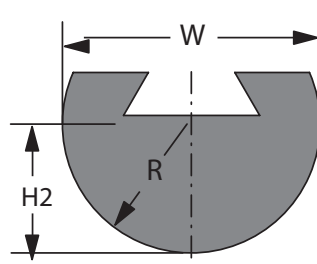

Typ B

Höhe - H	130 mm
Höhe - H1	44 mm
Höhe - H2	35 mm

(Standard)



Radius	Typ	Gewicht	Standardlänge	Teilenummer
R = 5	A	12.4 kg/m	515	65200.0005.5002
			550 FSW	65200.0005.9001
			1000 FSC	65200.0005.0002
R = 6	A	12.7 kg/m	515	65200.0006.5005
			550 FSW	65200.0006.9001
			1000 FSC	65200.0006.0002
R = 8	A	13.4 kg/m	515	65200.0008.5003
			550 FSW	65200.0008.9001
			1000 FSC	65200.0008.0003
R = 10	A	14.0 kg/m	515	65200.0010.5004
			550 FSW	65200.0010.9001
			1000 FSC	65200.0010.0003
R = 12	A	14.5 kg/m	515	65200.0012.5005
			550 FSW	65200.0012.9001
			1000 FSC	65200.0012.0001
R = 15	A	15.2 kg/m	515	65200.0015.5002
			550 FSW	65200.0015.9001
			1000 FSC	65200.0015.0003
R = 20	A	16.2 kg/m	515	65200.0020.5004
			550 FSW	65200.0020.9001
			1000 FSC	65200.0020.0001
R = 25	B	13.4 kg/m	515	65200.0025.5005
			550 FSW	65200.0025.9001
			1000 FSC	65200.0025.0001
R = 30	B	15.7 kg/m	515	65200.0030.5004
			550 FSW	65200.0030.9001
			1000 FSC	65200.0030.0002
R = 35	B	18.4 kg/m	515	65200.0035.5003
			550 FSW	65200.0035.9001
			1000 FSC	65200.0035.0001



P13 RF-A

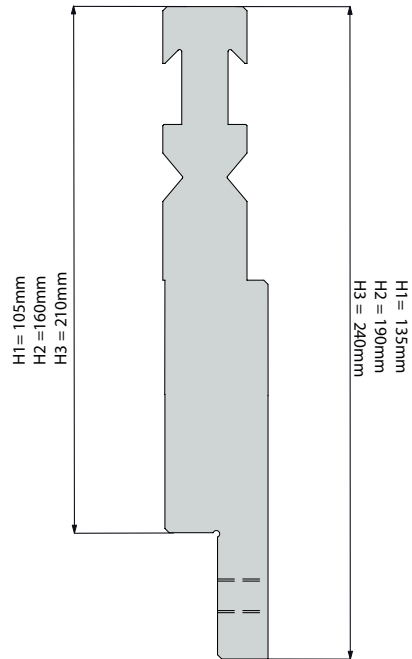
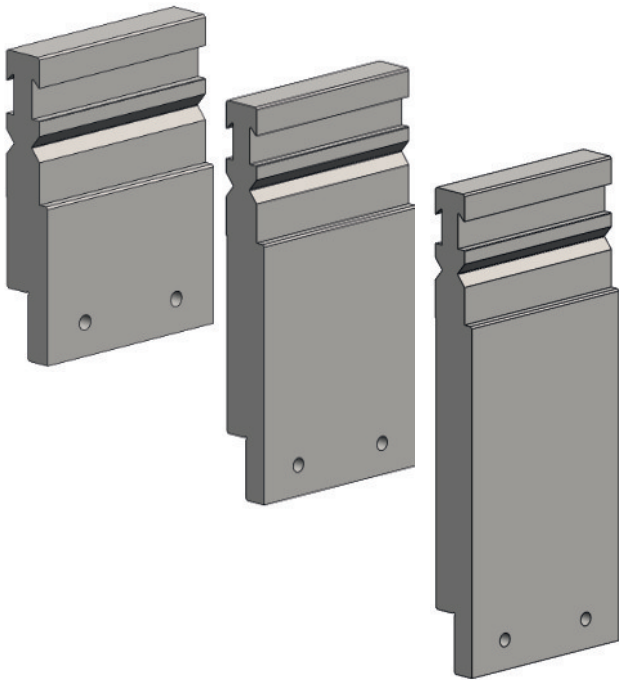

[R] Radius (mm)	-
Spitzenwinkel	-

Bestell-Nr. Datenblatt OTD	H = 105/135: 10166075
	H = 160/190: 10166078
	H = 210/240: 10166079

Modell	Standardlänge	Teilenummer
P13 RF-A H=105/135	50 mm	65206.0013.5001
	55 mm	65206.0013.5002
	60 mm	65206.0013.5003
	65 mm	65206.0013.5004
	70 mm	65206.0013.5005
	80 mm	65206.0013.5006
	85 mm	65206.0013.5007
	90 mm	65206.0013.5008
	95 mm	65206.0013.5009
	100 mm	65206.0013.5010
	200 mm	65206.0013.5011
	500 mm	65206.0013.5012
	1000 mm sect.	65206.0013.0001
	75 mm	65206.0013.5039

1000 sect. = 50 mm, 55 mm, 60 mm, 2 × 65 mm, 2 × 70 mm, 80 mm, 90 mm, 95 mm, 100 mm, 200 mm



F max = 1600 kN/m



19.1 kg/m



Modell	Standardlänge	Teilenummer
P13 RF-A H=160/190	50 mm	65206.0013.5013
	55 mm	65206.0013.5014
	60 mm	65206.0013.5015
	65 mm	65206.0013.5016
	70 mm	65206.0013.5017
	80 mm	65206.0013.5018
	85 mm	65206.0013.5019
	90 mm	65206.0013.5020
	95 mm	65206.0013.5021
	100 mm	65206.0013.5022
	200 mm	65206.0013.5023
	500 mm	65206.0013.5024
	1000 mm sect.	65206.0013.0002
	75 mm	65206.0013.5038

1000 sect. = 50 mm, 55 mm, 60 mm, 2 × 65 mm, 2 × 70 mm, 80 mm, 90 mm, 95 mm, 100 mm, 200 mm



$F_{max} = 1600 \text{ kN/m}$



29.6 kg/m

Modell	Standardlänge	Teilenummer
P13 RF-A H=210/240	50 mm	65206.0013.5025
	55 mm	65206.0013.5026
	60 mm	65206.0013.5027
	65 mm	65206.0013.5028
	70 mm	65206.0013.5029
	80 mm	65206.0013.5030
	85 mm	65206.0013.5031
	90 mm	65206.0013.5032
	95 mm	65206.0013.5033
	100 mm	65206.0013.5034
	200 mm	65206.0013.5035
	500 mm	65206.0013.5036
	1000 mm sect.	65206.0013.0003
	75 mm	65206.0013.5037

1000 sect. = 50 mm, 55 mm, 60 mm, 2 × 65 mm, 2 × 70 mm, 80 mm, 90 mm, 95 mm, 100 mm, 200 mm



$F_{max} = 1600 \text{ kN/m}$



39.2 kg/m



Adapter P25 RF-A

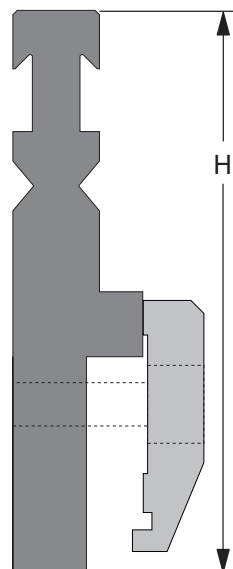
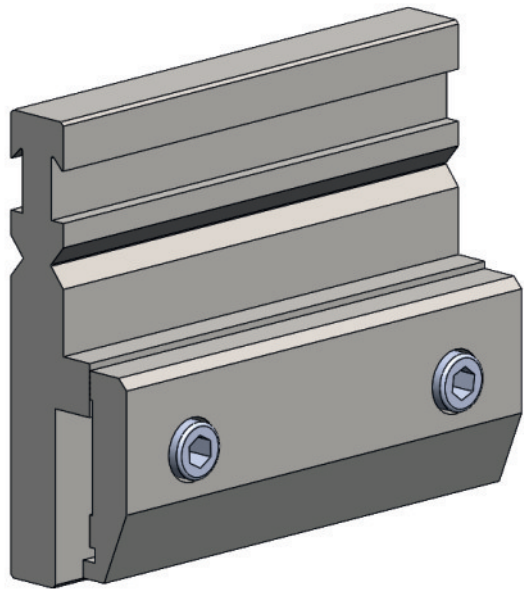

[R] Radius (mm)	-
Spitzenwinkel	-

Art	Standardlänge	Höhe	Teilenummer	Bestell-Nr. Datenblatt OTD
P25 RF-A/EURO-B	150 mm	130 mm	64600.0000.0033	10166103
P25 RF-A/R	150 mm	164 mm	64600.0000.0091	10166087
P25 RF-A/XPT	150 mm	130 mm	64600.0000.0083	10166088
P25 RF-A/EURO-B	150 mm	250 mm	64600.0000.0037	10166104



F max = 2000 kN/m



Verlängerung P30

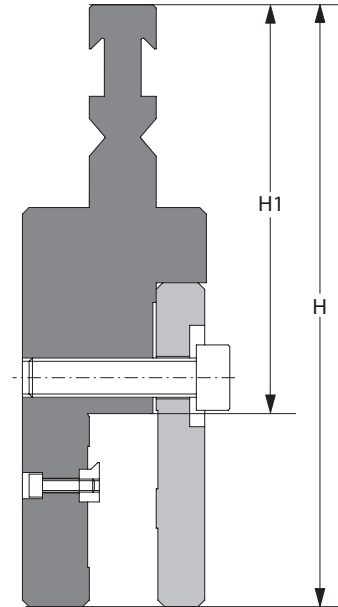
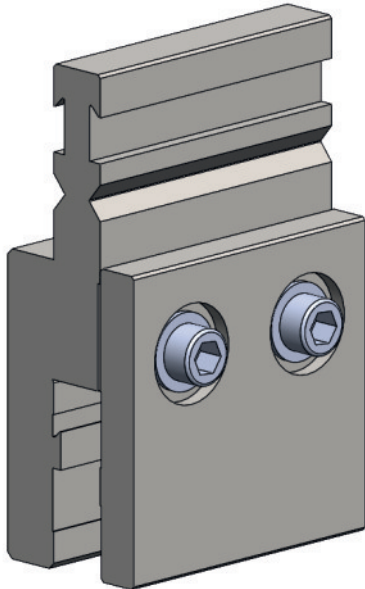

[R] Radius (mm)	-
Spitzenwinkel	-

Art	Standardlänge	Höhe H1/H	Teilenummer	Bestell-Nr. Datenblatt OTD
P30 RF-A/RF	150 mm	101/160 mm	64600.0000.0034	10166089
P30 RF-A/RF	150 mm	125/184 mm	64600.0000.0024	10166091
P30 RF-A/RF	150 mm	150/209 mm	64600.0000.0119	10166093
P30 RF-A/RF	150 mm	175/234 mm	64600.0000.0125	10166096
P30 RF-A/RF	150 mm	200/259 mm	64600.0000.0039	10166097
P30 RF-A/RF	150 mm	250/309 mm	64600.0000.0032	10166098



F max = 2000 kN/m



Unterwerkzeuge

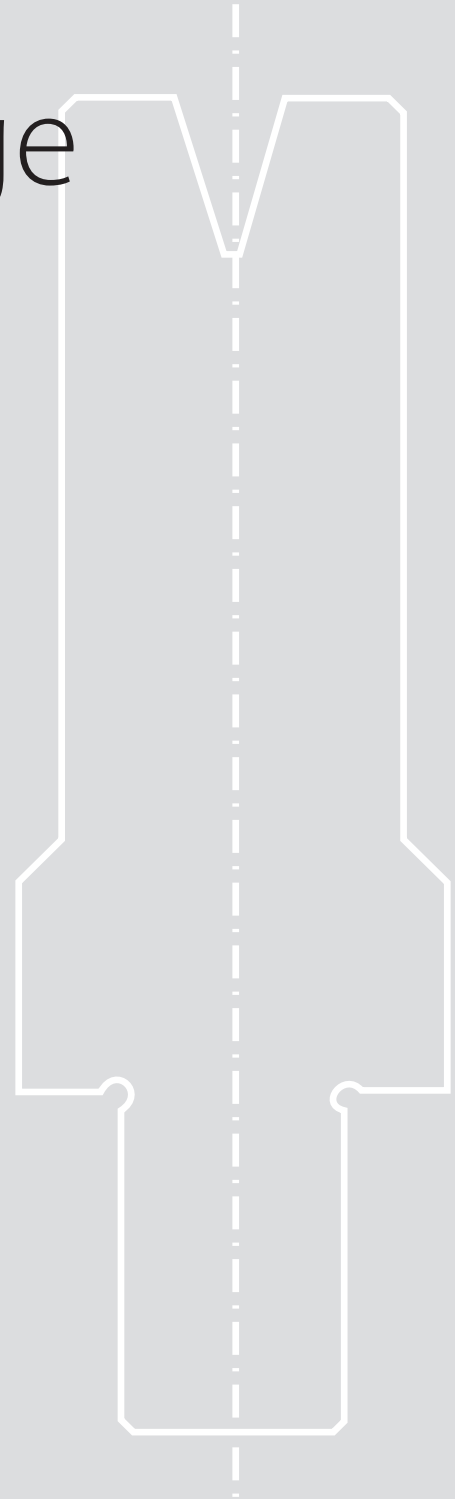





Untertischoptionen

Tische für größere Unterwerkzeuge

T5

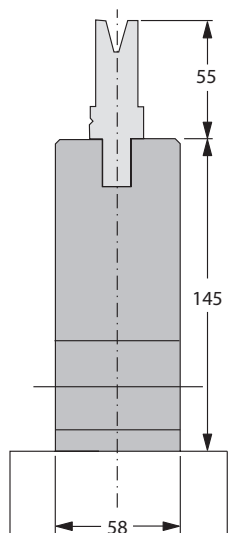

T55

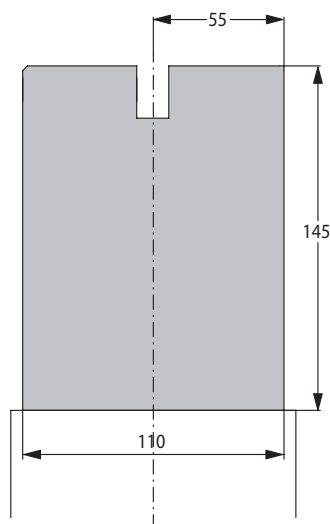

T2 (Standard)

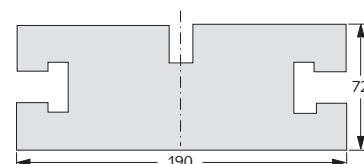

Tische für hydraulische Werkzeugklemmung

T12

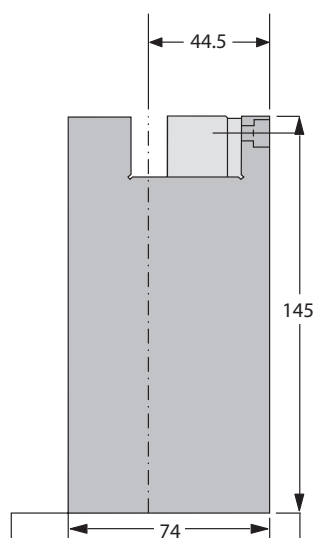

T13

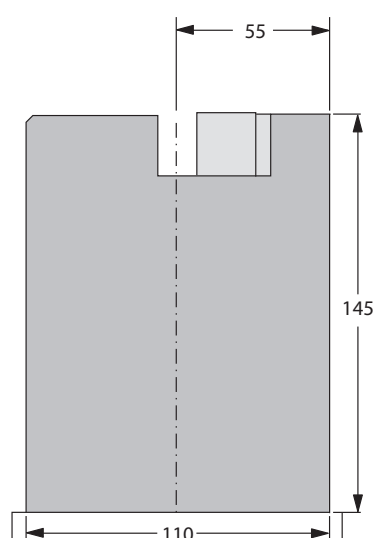



Untertischoptionen

Hydraulischer Zudrücktisch mit hydraulischer Matrizenklemmung

DD009 HI

geöffnet

geschlossen

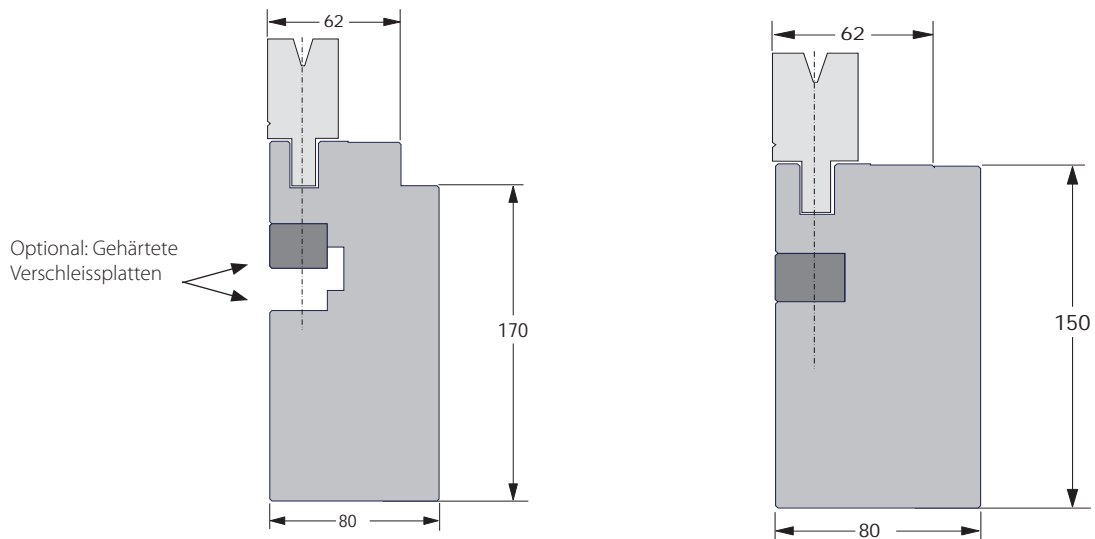



Unterwerkzeugteilung

FSC / 1000 mm

(10 + 15 + 20 + 30 + 50 + 100 + 200 + 275 + 300)



10	15	20	30	50	100	200	275	300

FSW / 550 mm

(20 + 25 + 30 + 35 + 40 + 200 + 2 x 100)



20	25	30	35	40	100	100	200

Sonderteilung auf Anfrage.

Darüber hinaus können alle Unterwerkzeuge mit modifizierten Radien, Matrizenwinkeln und Höhen (abweichend vom Standard) geliefert werden.





V4/30° H55

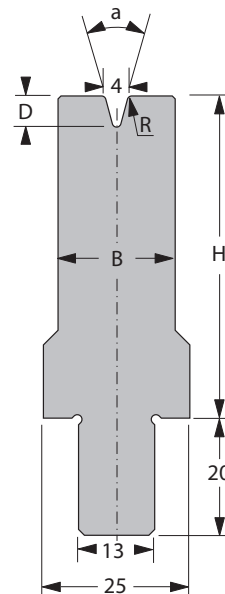
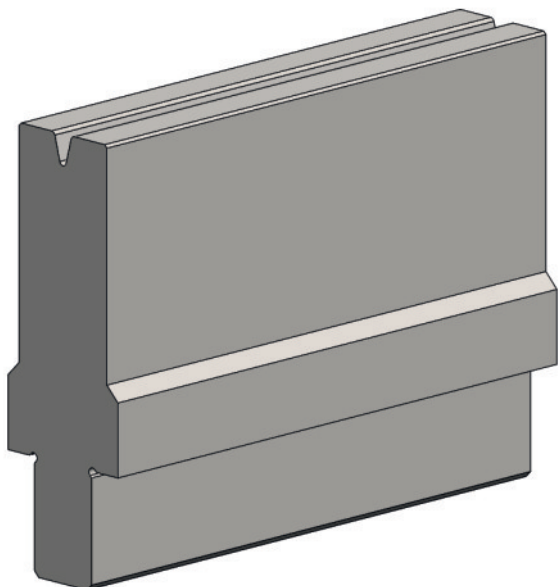

[R] Radius (mm)	0.75
[a] V - Winkel	30°
[H] Höhe (mm)	55

[B] Breite (mm)	20
[T] Tiefe (mm)	5.3

Bestell-Nr. Datenblatt OTD: 10165548

Standardlänge	Teilenummer
10 mm	64201.0004.5008
15 mm	64201.0004.5009
20 mm	64201.0004.5014
25 mm	64201.0004.5015
30 mm	64201.0004.5016
35 mm	64201.0004.5017
40 mm	64201.0004.5018
45 mm	64201.0004.5006
50 mm	64201.0004.5019
55 mm	64201.0004.5020
60 mm	64201.0004.5007
65 mm	64201.0004.5021
70 mm	64201.0004.5022
75 mm	64201.0004.5023

Standardlänge	Teilenummer
80 mm	64201.0004.5024
85 mm	64201.0004.5025
90 mm	64201.0004.5026
95 mm	64201.0004.5027
100 mm	64201.0004.5028
200 mm	64201.0004.5029
275 mm	64201.0004.5005
300 mm	64201.0004.5030
515 mm	64201.0004.5004
550 mm FSW	64201.0004.9001
1000 mm FSC	64201.0004.0001
1030 mm	64201.0004.3001



$F_{\max} 30^\circ = 220 \text{ kN/m}$
 $F_{\max} 90^\circ = 600 \text{ kN/m}$



11.0 kg/m



Matrizeneinsatz 13 mm



V4/30° H100

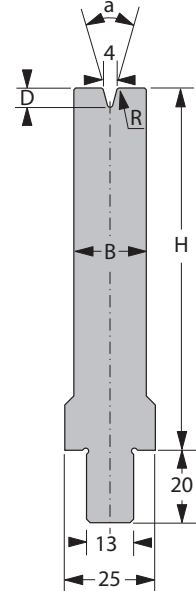
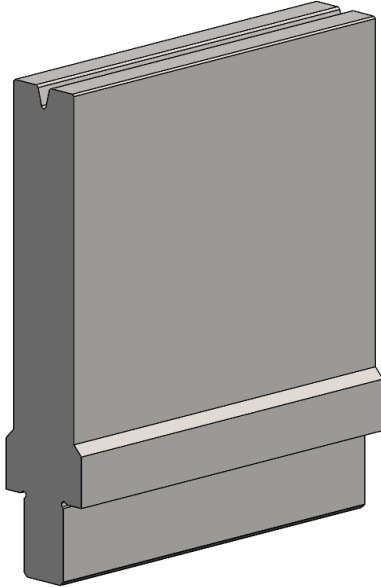

[R] Radius (mm)	0.75
[a] V - Winkel	30°
[H] Höhe (mm)	100

[B] Breite (mm)	20
[T] Tiefe (mm)	5.3
Bestell-Nr. Datenblatt OTD: 10165556	

Standardlänge	Teilenummer
10 mm	64201.0004.5031
15 mm	64201.0004.5032
20 mm	64201.0004.5033
25 mm	64201.0004.5034
30 mm	64201.0004.5035
35 mm	64201.0004.5036
40 mm	64201.0004.5037
45 mm	64201.0004.5038
50 mm	64201.0004.5039
55 mm	64201.0004.5040
60 mm	64201.0004.5041
65 mm	64201.0004.5042
70 mm	64201.0004.5043
75 mm	64201.0004.5044

Standardlänge	Teilenummer
80 mm	64201.0004.5045
85 mm	64201.0004.5046
90 mm	64201.0004.5047
95 mm	64201.0004.5048
100 mm	64201.0004.5049
200 mm	64201.0004.5050
275 mm	64201.0004.5051
300 mm	64201.0004.5052
515 mm	64201.0004.5053
550 mm FSW	64201.0004.9004
1000 mm FSC	64201.0004.0002
1030 mm	64201.0004.3002



F max 30° = 220 kN/m
F max 90° = 600 kN/m



18.0 kg/m



Matrizeneinsatz 13 mm



V4/85° H55

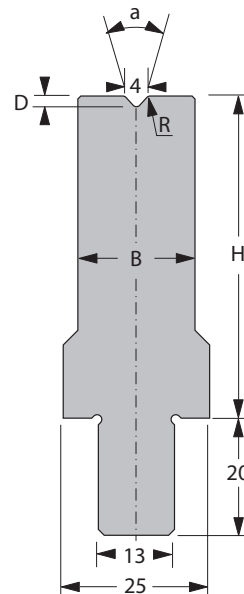
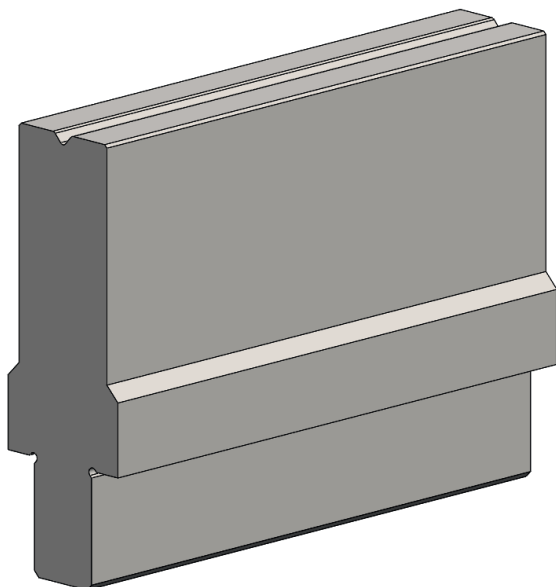

[R] Radius (mm)	0.75
[a] V - Winkel	85°
[H] Höhe (mm)	55

[B] Breite (mm)	20
[T] Tiefe (mm)	1.8

Bestell-Nr. Datenblatt OTD: 10163810

Standardlänge	Teilenummer
10 mm	64201.0004.5010
15 mm	64201.0004.5011
20 mm	64201.0004.5054
25 mm	64201.0004.5055
30 mm	64201.0004.5056
35 mm	64201.0004.5057
40 mm	64201.0004.5058
45 mm	64201.0004.5059
50 mm	64201.0004.5060
55 mm	64201.0004.5061
60 mm	64201.0004.5062
65 mm	64201.0004.5063
70 mm	64201.0004.5064
75 mm	64201.0004.5065

Standardlänge	Teilenummer
80 mm	64201.0004.5066
85 mm	64201.0004.5067
90 mm	64201.0004.5068
95 mm	64201.0004.5069
100 mm	64201.0004.5070
200 mm	64201.0004.5071
275 mm	64201.0004.5072
300 mm	64201.0004.5073
515 mm	64201.0004.5074
550 mm FSW	64201.0004.9003
1000 mm FSC	64201.0004.0003
1030 mm	64201.0004.3003



F max 90° = 600 kN/m



11.1 kg/m



Matrizeneinsatz 13 mm



V4/85° H100

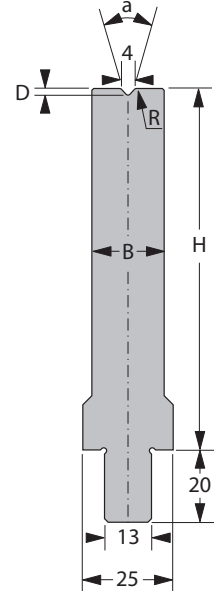
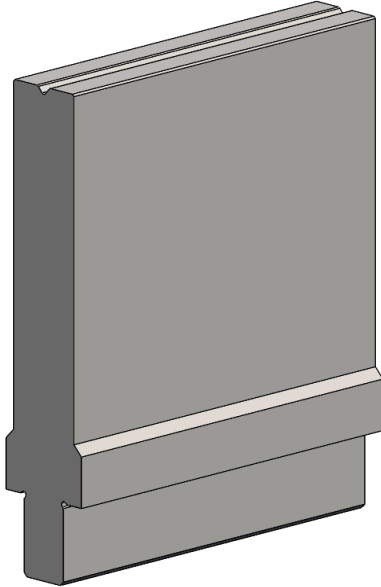

[R] Radius (mm)	0.75
[a] V - Winkel	85°
[H] Höhe (mm)	100

[B] Breite (mm)	20
[T] Tiefe (mm)	1.8
Bestell-Nr. Datenblatt OTD: 10164778	

Standardlänge	Teilenummer
10 mm	64201.0004.5075
15 mm	64201.0004.5076
20 mm	64201.0004.5077
25 mm	64201.0004.5078
30 mm	64201.0004.5079
35 mm	64201.0004.5080
40 mm	64201.0004.5081
45 mm	64201.0004.5082
50 mm	64201.0004.5083
55 mm	64201.0004.5084
60 mm	64201.0004.5085
65 mm	64201.0004.5086
70 mm	64201.0004.5087
75 mm	64201.0004.5088

Standardlänge	Teilenummer
80 mm	64201.0004.5089
85 mm	64201.0004.5090
90 mm	64201.0004.5091
95 mm	64201.0004.5092
100 mm	64201.0004.5093
200 mm	64201.0004.5094
275 mm	64201.0004.5095
300 mm	64201.0004.5096
515 mm	64201.0004.5097
550 mm FSW	64201.0004.9005
1000 mm FSC	64201.0004.0004
1030 mm	64201.0004.3004



F max 90° = 600 kN/m



18.2 kg/m



Matrizeneinsatz 13 mm



V4S/30° H55

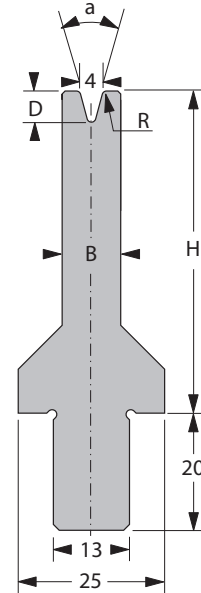
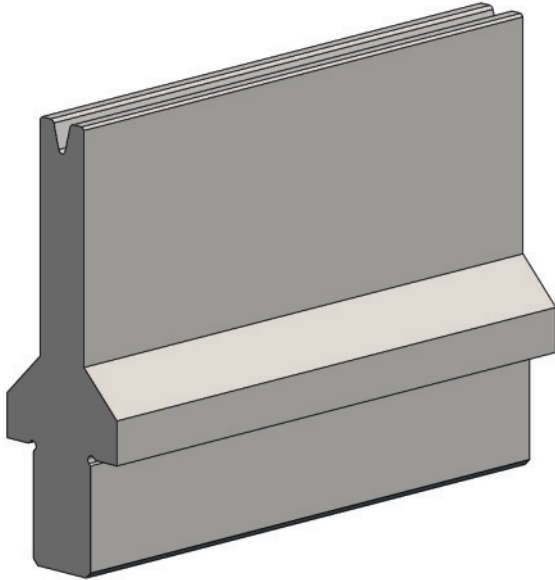

[R] Radius (mm)	0.75
[a] V - Winkel	30°
[H] Höhe (mm)	55

[B] Breite (mm)	10
[T] Tiefe (mm)	5.3

Bestell-Nr. Datenblatt OTD: 10165559

Standardlänge	Teilenummer
10 mm	64201.0004.5106
15 mm	64201.0004.5107
20 mm	64201.0004.5108
25 mm	64201.0004.5109
30 mm	64201.0004.5110
35 mm	64201.0004.5111
40 mm	64201.0004.5112
45 mm	64201.0004.5113
50 mm	64201.0004.5114
55 mm	64201.0004.5115
60 mm	64201.0004.5116
65 mm	64201.0004.5117
70 mm	64201.0004.5118
75 mm	64201.0004.5119

Standardlänge	Teilenummer
80 mm	64201.0004.5120
85 mm	64201.0004.5121
90 mm	64201.0004.5122
95 mm	64201.0004.5123
100 mm	64201.0004.5124
200 mm	64201.0004.5125
275 mm	64201.0004.5126
300 mm	64201.0004.5127
515 mm	64201.0004.5102
550 mm FSW	64201.0004.9102
1000 mm FSC	64201.0004.0103
1030 mm	64201.0004.3102



$F_{\max} 30^\circ = 140 \text{ kN/m}$
 $F_{\max} 90^\circ = 400 \text{ kN/m}$



7.5 kg/m



Matrizeneinsatz 13 mm



V4S/30° H100

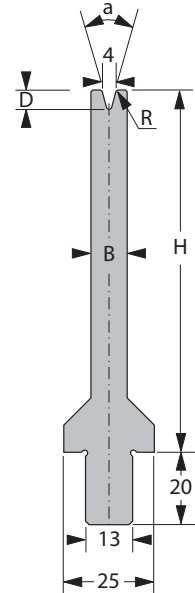
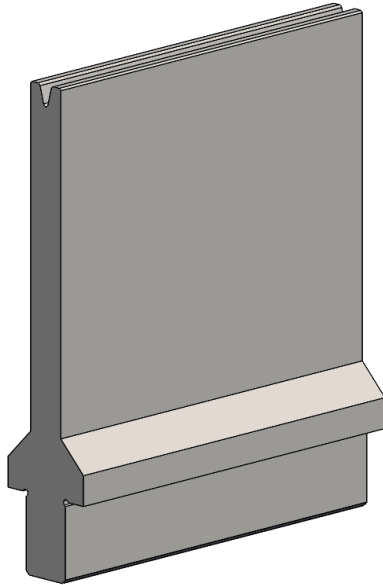

[R] Radius (mm)	0.75
[a] V - Winkel	30°
[H] Höhe (mm)	100

[B] Breite (mm)	10
[T] Tiefe (mm)	5.3
Bestell-Nr. Datenblatt OTD: 10165560	

Standardlänge	Teilenummer
10 mm	64201.0004.5128
15 mm	64201.0004.5129
20 mm	64201.0004.5130
25 mm	64201.0004.5131
30 mm	64201.0004.5132
35 mm	64201.0004.5133
40 mm	64201.0004.5134
45 mm	64201.0004.5135
50 mm	64201.0004.5136
55 mm	64201.0004.5137
60 mm	64201.0004.5138
65 mm	64201.0004.5139
70 mm	64201.0004.5140
75 mm	64201.0004.5141

Standardlänge	Teilenummer
80 mm	64201.0004.5142
85 mm	64201.0004.5143
90 mm	64201.0004.5144
95 mm	64201.0004.5145
100 mm	64201.0004.5146
200 mm	64201.0004.5147
275 mm	64201.0004.5148
300 mm	64201.0004.5149
515 mm	64201.0004.5104
550 mm FSW	64201.0004.9101
1000 mm FSC	64201.0004.0106
1030 mm	64201.0004.3103



F max 30° = 140 kN/m
F max 90° = 400 kN/m



11.1 kg/m



Matrizeneinsatz 13 mm



V4S/85° H55

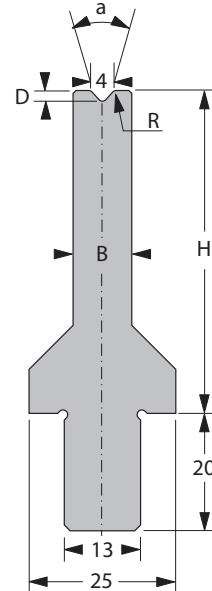
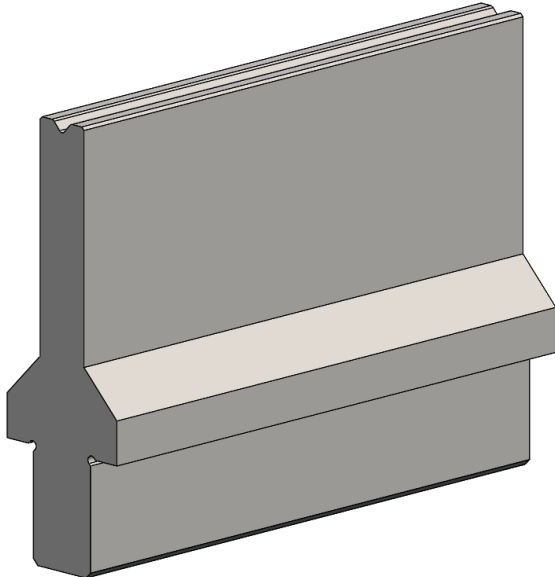

[R] Radius (mm)	0.75
[a] V - Winkel	85°
[H] Höhe (mm)	55

[B] Breite (mm)	10
[T] Tiefe (mm)	1.8

Bestell-Nr. Datenblatt OTD: 10164783

Standardlänge	Teilenummer
10 mm	64201.0004.5150
15 mm	64201.0004.5151
20 mm	64201.0004.5152
25 mm	64201.0004.5153
30 mm	64201.0004.5154
35 mm	64201.0004.5155
40 mm	64201.0004.5156
45 mm	64201.0004.5157
50 mm	64201.0004.5158
55 mm	64201.0004.5159
60 mm	64201.0004.5160
65 mm	64201.0004.5161
70 mm	64201.0004.5162
75 mm	64201.0004.5163

Standardlänge	Teilenummer
80 mm	64201.0004.5164
85 mm	64201.0004.5165
90 mm	64201.0004.5166
95 mm	64201.0004.5167
100 mm	64201.0004.5168
200 mm	64201.0004.5169
275 mm	64201.0004.5170
300 mm	64201.0004.5171
515 mm	64201.0004.5172
550 mm FSW	64201.0004.9103
1000 mm FSC	64201.0004.0107
1030 mm	64201.0004.3104



F max 90° = 400 kN/m



7.6 kg/m



Matrizeneinsatz 13 mm



V4S/85° H100

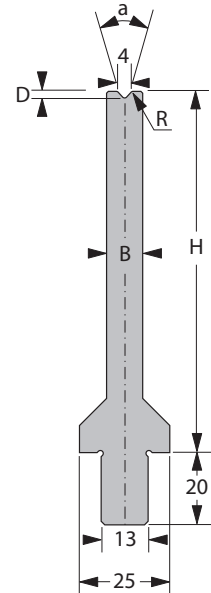
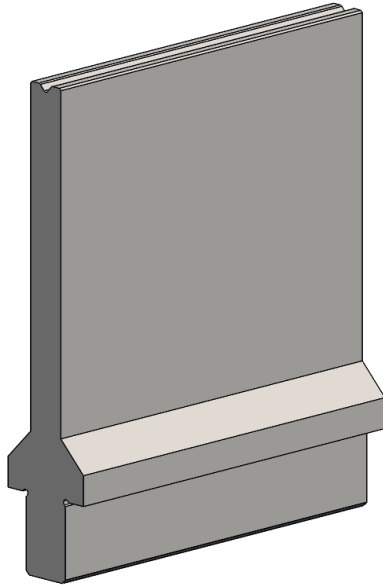

[R] Radius (mm)	0.75
[a] V - Winkel	85°
[H] Höhe (mm)	100

[B] Breite (mm)	10
[T] Tiefe (mm)	1.8
Bestell-Nr. Datenblatt OTD: 10164786	

Standardlänge	Teilenummer
10 mm	64201.0004.5173
15 mm	64201.0004.5174
20 mm	64201.0004.5175
25 mm	64201.0004.5176
30 mm	64201.0004.5177
35 mm	64201.0004.5178
40 mm	64201.0004.5179
45 mm	64201.0004.5180
50 mm	64201.0004.5181
55 mm	64201.0004.5182
60 mm	64201.0004.5183
65 mm	64201.0004.5184
70 mm	64201.0004.5185
75 mm	64201.0004.5186

Standardlänge	Teilenummer
80 mm	64201.0004.5187
85 mm	64201.0004.5188
90 mm	64201.0004.5189
95 mm	64201.0004.5190
100 mm	64201.0004.5191
200 mm	64201.0004.5192
275 mm	64201.0004.5193
300 mm	64201.0004.5194
515 mm	64201.0004.5195
550 mm FSW	64201.0004.9104
1000 mm FSC	64201.0004.0108
1030 mm	64201.0004.3105



F max 90° = 400 kN/m



11.1 kg/m



Matrizeneinsatz 13 mm



V6/30° H55

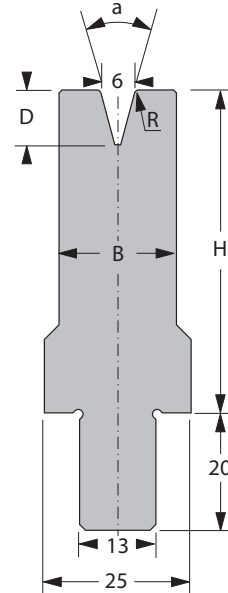
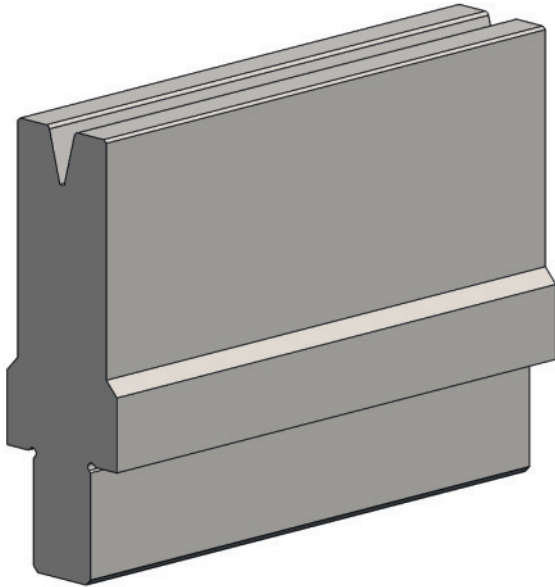

[R] Radius (mm)	0.75
[a] V - Winkel	30°
[H] Höhe (mm)	55

[B] Breite (mm)	20
[T] Tiefe (mm)	9.3
Bestell-Nr. Datenblatt OTD: 10165562	

Standardlänge	Teilenummer
10 mm	64201.0006.5034
15 mm	64201.0006.5048
20 mm	64201.0006.5028
25 mm	64201.0006.5039
30 mm	64201.0006.5029
35 mm	64201.0006.5036
40 mm	64201.0006.5037
45 mm	64201.0006.5038
50 mm	64201.0006.5030
55 mm	64201.0006.5076
60 mm	64201.0006.5077
65 mm	64201.0006.5078
70 mm	64201.0006.5079
75 mm	64201.0006.5080

Standardlänge	Teilenummer
80 mm	64201.0006.5081
85 mm	64201.0006.5009
90 mm	64201.0006.5082
95 mm	64201.0006.5083
100 mm	64201.0006.5008
200 mm	64201.0006.5023
275 mm	64201.0006.5027
300 mm	64201.0006.5007
515 mm	64201.0006.5004
550 mm FSW	64201.0006.9001
1000 mm FSC	64201.0006.0001
1030 mm	64201.0006.3008



$F_{\max} 30^\circ = 280 \text{ kN/m}$
 $F_{\max} 90^\circ = 800 \text{ kN/m}$



10.9 kg/m



Matrizeneinsatz 13 mm



V6/30° H100

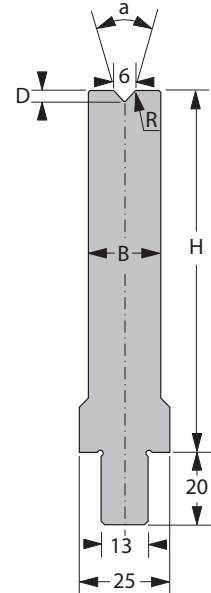
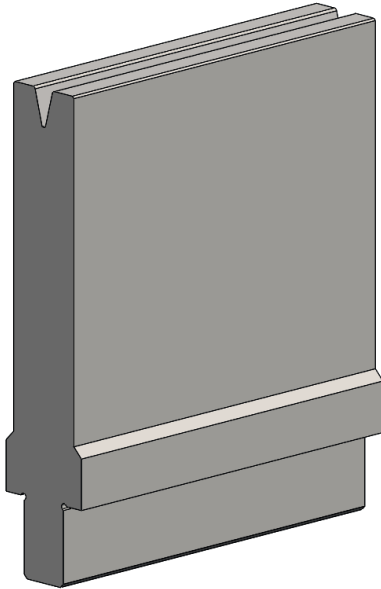

[R] Radius (mm)	0.75
[a] V - Winkel	30°
[H] Höhe (mm)	100

[B] Breite (mm)	20
[T] Tiefe (mm)	9.3
Bestell-Nr. Datenblatt OTD: 10165564	

Standardlänge	Teilenummer
10 mm	64201.0006.5057
15 mm	64201.0006.5084
20 mm	64201.0006.5085
25 mm	64201.0006.5046
30 mm	64201.0006.5047
35 mm	64201.0006.5042
40 mm	64201.0006.5043
45 mm	64201.0006.5044
50 mm	64201.0006.5045
55 mm	64201.0006.5086
60 mm	64201.0006.5087
65 mm	64201.0006.5088
70 mm	64201.0006.5089
75 mm	64201.0006.5090

Standardlänge	Teilenummer
80 mm	64201.0006.5091
85 mm	64201.0006.5092
90 mm	64201.0006.5093
95 mm	64201.0006.5094
100 mm	64201.0006.5041
200 mm	64201.0006.5024
275 mm	64201.0006.5095
300 mm	64201.0006.5040
515 mm	64201.0006.5013
550 mm FSW	64201.0006.9002
1000 mm FSC	64201.0006.0009
1030 mm	64201.0006.3013



F max 30° = 280 kN/m
F max 90° = 800 kN/m



18.0 kg/m



Matrizeneinsatz 13 mm



V6/85° H55

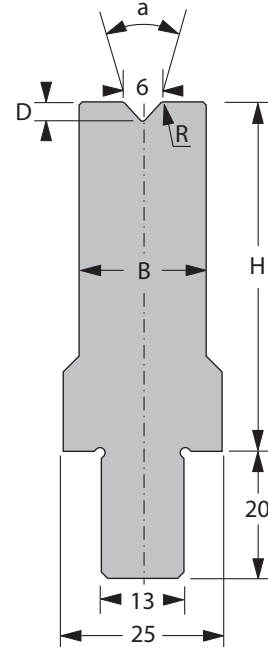
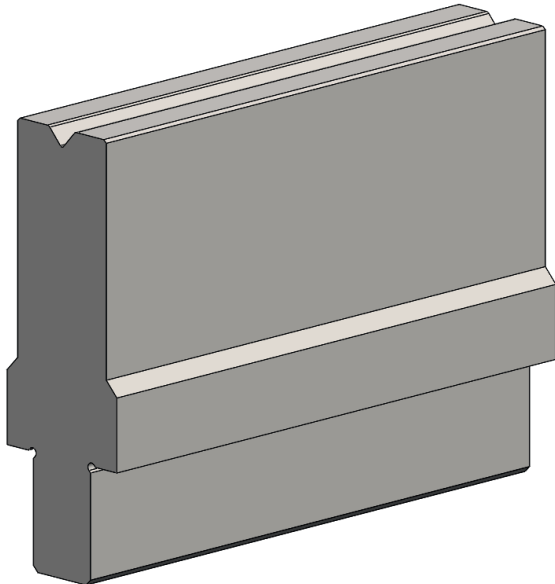

[R] Radius (mm)	0.75
[a] V - Winkel	85°
[H] Höhe (mm)	55

[B] Breite (mm)	12
[T] Tiefe (mm)	3.0

Bestell-Nr. Datenblatt OTD: 10164787

Standardlänge	Teilenummer
10 mm	64201.0006.5055
15 mm	64201.0006.5066
20 mm	64201.0006.5058
25 mm	64201.0006.5059
30 mm	64201.0006.5060
35 mm	64201.0006.5061
40 mm	64201.0006.5062
45 mm	64201.0006.5063
50 mm	64201.0006.5064
55 mm	64201.0006.5065
60 mm	64201.0006.5096
65 mm	64201.0006.5097
70 mm	64201.0006.5098
75 mm	64201.0006.5099

Standardlänge	Teilenummer
80 mm	64201.0006.5100
85 mm	64201.0006.5212
90 mm	64201.0006.5213
95 mm	64201.0006.5214
100 mm	64201.0006.5215
200 mm	64201.0006.5216
275 mm	64201.0006.5217
300 mm	64201.0006.5218
515 mm	64201.0006.5005
550 mm FSW	64201.0006.9006
1000 mm FSC	64201.0006.0005
1030 mm	64201.0006.3011



F max 90° = 800 kN/m



8.3 kg/m



Matrizeneinsatz 13 mm



V6/85° H100

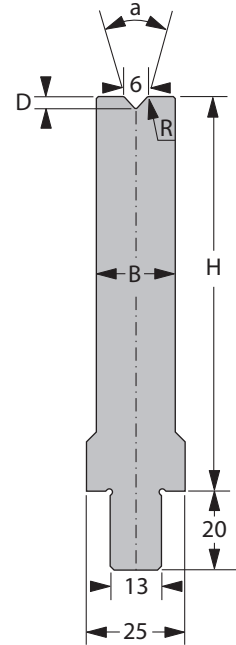
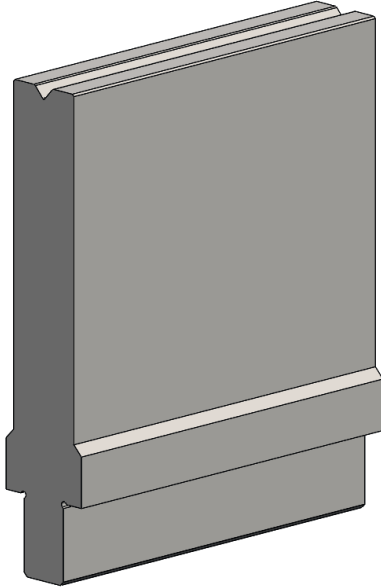

[R] Radius (mm)	0.75
[a] V - Winkel	85°
[H] Höhe (mm)	100

[B] Breite (mm)	12
[T] Tiefe (mm)	3.0
Bestell-Nr. Datenblatt OTD: 10164788	

Standardlänge	Teilenummer
10 mm	64201.0006.5219
15 mm	64201.0006.5220
20 mm	64201.0006.5221
25 mm	64201.0006.5222
30 mm	64201.0006.5223
35 mm	64201.0006.5224
40 mm	64201.0006.5225
45 mm	64201.0006.5226
50 mm	64201.0006.5227
55 mm	64201.0006.5228
60 mm	64201.0006.5229
65 mm	64201.0006.5230
70 mm	64201.0006.5231
75 mm	64201.0006.5232

Standardlänge	Teilenummer
80 mm	64201.0006.5233
85 mm	64201.0006.5234
90 mm	64201.0006.5235
95 mm	64201.0006.5236
100 mm	64201.0006.5237
200 mm	64201.0006.5238
275 mm	64201.0006.5239
300 mm	64201.0006.5240
515 mm	64201.0006.5241
550 mm FSW	64201.0006.9011
1000 mm FSC	64201.0006.0025
1030 mm	64201.0006.3017



F max 90° = 800 kN/m



12.5 kg/m



Matrizeneinsatz 13 mm



V6S/30° H55

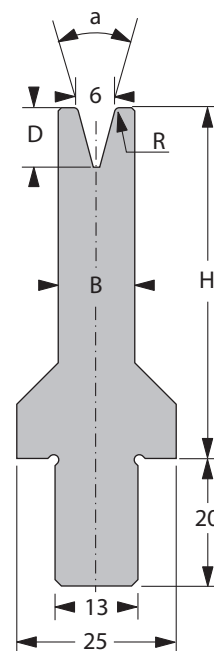
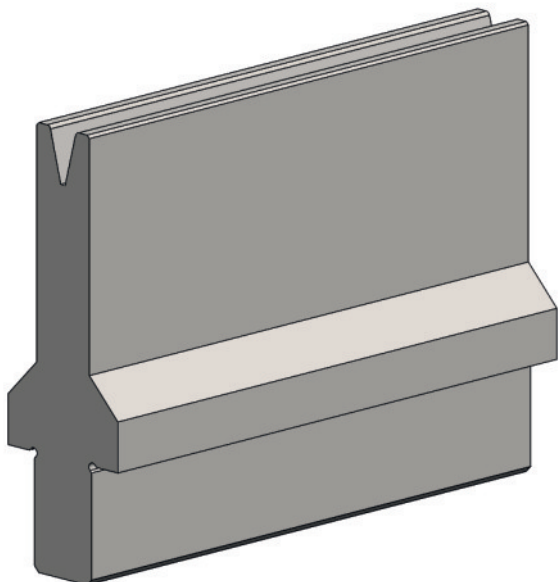

[R] Radius (mm)	0.75
[a] V - Winkel	30°
[H] Höhe (mm)	55

[B] Breite (mm)	12
[T] Tiefe (mm)	9.3

Bestell-Nr. Datenblatt OTD: 10165565

Standardlänge	Teilenummer
10 mm	64201.0006.5035
15 mm	64201.0006.5120
20 mm	64201.0006.5129
25 mm	64201.0006.5139
30 mm	64201.0006.5121
35 mm	64201.0006.5140
40 mm	64201.0006.5141
45 mm	64201.0006.5142
50 mm	64201.0006.5135
55 mm	64201.0006.5143
60 mm	64201.0006.5144
65 mm	64201.0006.5145
70 mm	64201.0006.5146
75 mm	64201.0006.5147

Standardlänge	Teilenummer
80 mm	64201.0006.5148
85 mm	64201.0006.5149
90 mm	64201.0006.5150
95 mm	64201.0006.5151
100 mm	64201.0006.5122
200 mm	64201.0006.5109
275 mm	64201.0006.5134
300 mm	64201.0006.5136
515 mm	64201.0006.5104
550 mm FSW	64201.0006.9101
1000 mm FSC	64201.0006.0102
1030 mm	64201.0006.3103



$F_{\max} 30^\circ = 110 \text{ kN/m}$
 $F_{\max} 90^\circ = 400 \text{ kN/m}$



8.1 kg/m



Matrizeneinsatz 13 mm



V6S/30° H100

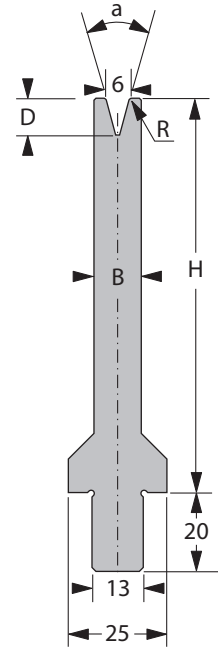
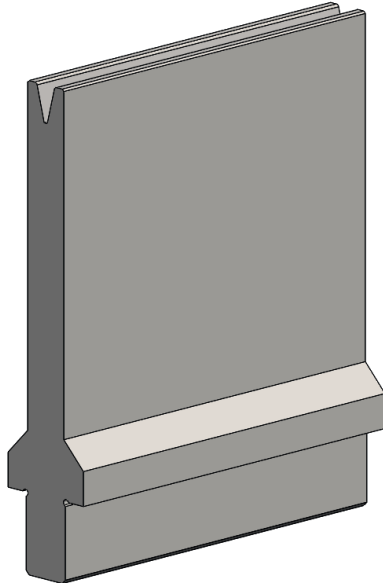

[R] Radius (mm)	0.75
[a] V - Winkel	30°
[H] Höhe (mm)	100

[B] Breite (mm)	12
[T] Tiefe (mm)	9.3
Bestell-Nr. Datenblatt OTD: 10165566	

Standardlänge	Teilenummer
10 mm	64201.0006.5152
15 mm	64201.0006.5153
20 mm	64201.0006.5154
25 mm	64201.0006.5155
30 mm	64201.0006.5156
35 mm	64201.0006.5157
40 mm	64201.0006.5158
45 mm	64201.0006.5159
50 mm	64201.0006.5160
55 mm	64201.0006.5161
60 mm	64201.0006.5162
65 mm	64201.0006.5163
70 mm	64201.0006.5164
75 mm	64201.0006.5165

Standardlänge	Teilenummer
80 mm	64201.0006.5166
85 mm	64201.0006.5167
90 mm	64201.0006.5168
95 mm	64201.0006.5169
100 mm	64201.0006.5125
200 mm	64201.0006.5131
275 mm	64201.0006.5170
300 mm	64201.0006.5117
515 mm	64201.0006.5113
550 mm FSW	64201.0006.9004
1000 mm FSC	64201.0006.0112
1030 mm	64201.0006.3110



F max 30° = 110 kN/m
F max 90° = 400 kN/m



12.3 kg/m



Matrizeneinsatz 13 mm



V6S/85° H55

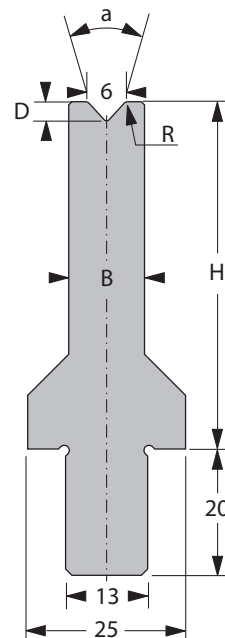
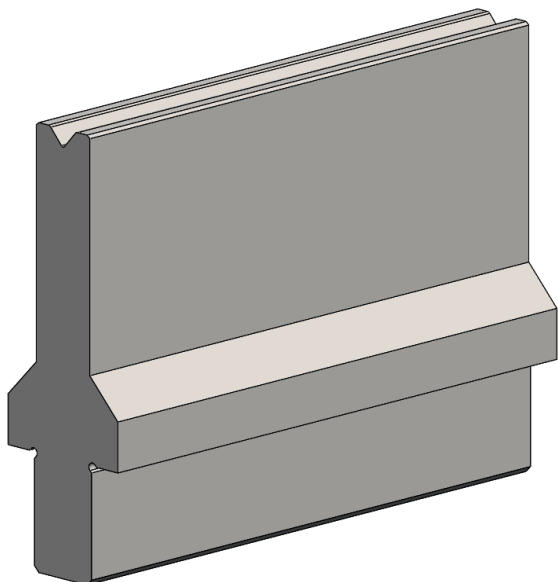

[R] Radius (mm)	0.75
[a] V - Winkel	85°
[H] Höhe (mm)	55

[B] Breite (mm)	12
[T] Tiefe (mm)	3.0

Bestell-Nr. Datenblatt OTD: 10164789

Standardlänge	Teilenummer
10 mm	64201.0006.5073
15 mm	64201.0006.5171
20 mm	64201.0006.5172
25 mm	64201.0006.5173
30 mm	64201.0006.5174
35 mm	64201.0006.5175
40 mm	64201.0006.5176
45 mm	64201.0006.5177
50 mm	64201.0006.5178
55 mm	64201.0006.5179
60 mm	64201.0006.5180
65 mm	64201.0006.5181
70 mm	64201.0006.5182
75 mm	64201.0006.5183

Standardlänge	Teilenummer
80 mm	64201.0006.5184
85 mm	64201.0006.5185
90 mm	64201.0006.5186
95 mm	64201.0006.5187
100 mm	64201.0006.5188
200 mm	64201.0006.5132
275 mm	64201.0006.5189
300 mm	64201.0006.5190
515 mm	64201.0006.5107
550 mm FSW	64201.0006.9010
1000 mm FSC	64201.0006.0106
1030 mm	64201.0006.3104



F max 90° = 800 kN/m



8.3 kg/m



Matrizeneinsatz 13 mm



V6S/85° H100

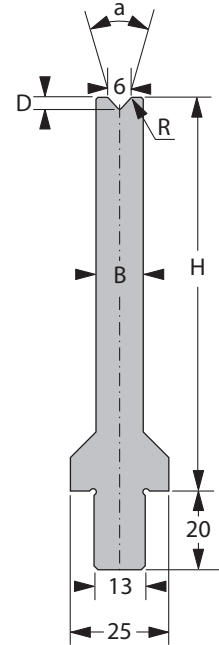
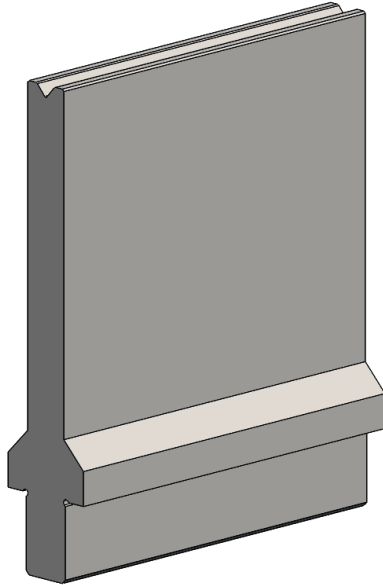

[R] Radius (mm)	0.75
[a] V - Winkel	85°
[H] Höhe (mm)	100

[B] Breite (mm)	12
[T] Tiefe (mm)	3.0
Bestell-Nr. Datenblatt OTD: 10164790	

Standardlänge	Teilenummer
10 mm	64201.0006.5191
15 mm	64201.0006.5192
20 mm	64201.0006.5193
25 mm	64201.0006.5194
30 mm	64201.0006.5195
35 mm	64201.0006.5196
40 mm	64201.0006.5197
45 mm	64201.0006.5198
50 mm	64201.0006.5199
55 mm	64201.0006.5200
60 mm	64201.0006.5201
65 mm	64201.0006.5202
70 mm	64201.0006.5203
75 mm	64201.0006.5204

Standardlänge	Teilenummer
80 mm	64201.0006.5205
85 mm	64201.0006.5206
90 mm	64201.0006.5207
95 mm	64201.0006.5208
100 mm	64201.0006.5209
200 mm	64201.0006.5054
275 mm	64201.0006.5210
300 mm	64201.0006.5211
515 mm	64201.0006.5053
550 mm FSW	64201.0006.9005
1000 mm FSC	64201.0006.0016
1030 mm	64201.0006.3109



F max 90° = 800 kN/m



12.5 kg/m



Matrizeneinsatz 13 mm



V8/30° H55

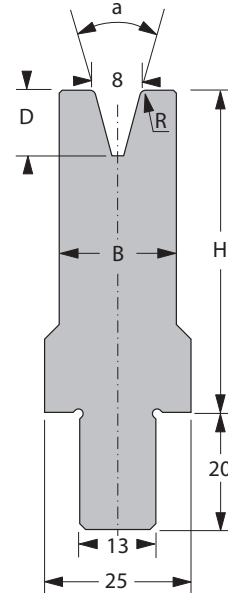
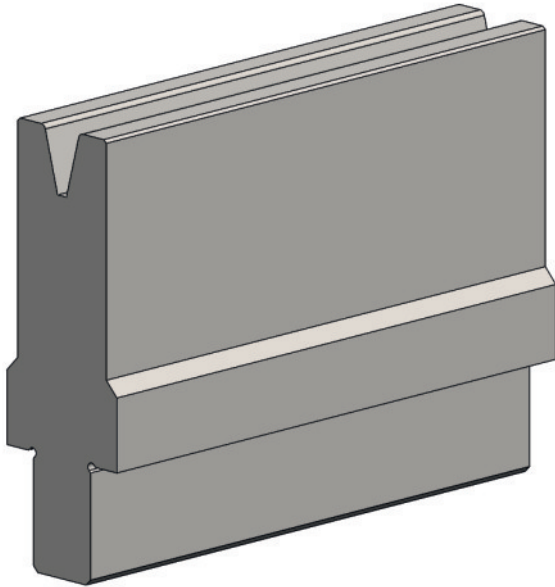

[R] Radius (mm)	1.0
[a] V - Winkel	30°
[H] Höhe (mm)	55

[B] Breite (mm)	20
[T] Tiefe (mm)	11.2
Bestell-Nr. Datenblatt OTD: 10165567	

Standardlänge	Teilenummer
10 mm	64201.0008.5053
15 mm	64201.0008.5044
20 mm	64201.0008.5054
25 mm	64201.0008.5146
30 mm	64201.0008.5055
35 mm	64201.0008.5083
40 mm	64201.0008.5062
45 mm	64201.0008.5097
50 mm	64201.0008.5096
55 mm	64201.0008.5098
60 mm	64201.0008.5099
65 mm	64201.0008.5100
70 mm	64201.0008.5155
75 mm	64201.0008.5156

Standardlänge	Teilenummer
80 mm	64201.0008.5157
85 mm	64201.0008.5158
90 mm	64201.0008.5159
95 mm	64201.0008.5160
100 mm	64201.0008.5010
200 mm	64201.0008.5032
275 mm	64201.0008.5161
300 mm	64201.0008.5036
515 mm	64201.0008.5012
550 mm FSW	64201.0008.9001
1000 mm FSC	64201.0008.0001
1030 mm	64201.0008.3005



F max 30° = 300 kN/m
F max 90° = 1000 kN/m



10.8 kg/m



Matrizeneinsatz 13 mm



V8/30° H100

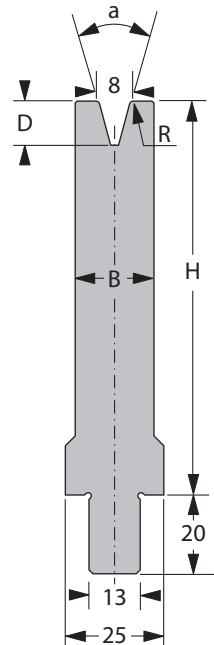
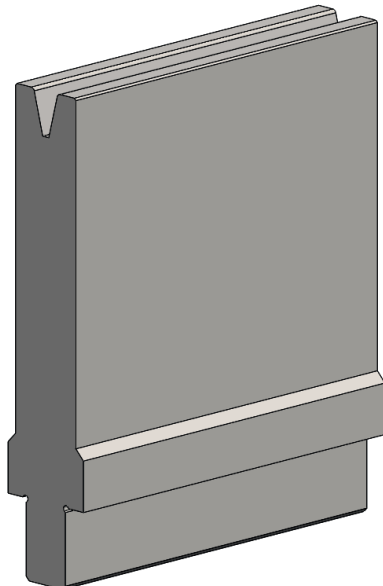

[R] Radius (mm)	1.0
[a] V - Winkel	30°
[H] Höhe (mm)	100

[B] Breite (mm)	20
[T] Tiefe (mm)	11.2
Bestell-Nr. Datenblatt OTD: 10165568	

Standardlänge	Teilenummer
10 mm	64201.0008.5180
15 mm	64201.0008.5181
20 mm	64201.0008.5085
25 mm	64201.0008.5182
30 mm	64201.0008.5183
35 mm	64201.0008.5184
40 mm	64201.0008.5185
45 mm	64201.0008.5186
50 mm	64201.0008.5187
55 mm	64201.0008.5188
60 mm	64201.0008.5189
65 mm	64201.0008.5190
70 mm	64201.0008.5191
75 mm	64201.0008.5192

Standardlänge	Teilenummer
80 mm	64201.0008.5193
85 mm	64201.0008.5194
90 mm	64201.0008.5195
95 mm	64201.0008.5196
100 mm	64201.0008.5092
200 mm	64201.0008.5033
275 mm	64201.0008.5197
300 mm	64201.0008.5198
515 mm	64201.0008.5020
550 mm FSW	64201.0008.9002
1000 mm FSC	64201.0008.0006
1030 mm	64201.0008.3012



F max 30° = 300 kN/m
F max 90° = 1000 kN/m



17.8 kg/m



Matrizeneinsatz 13 mm



V8/85° H55

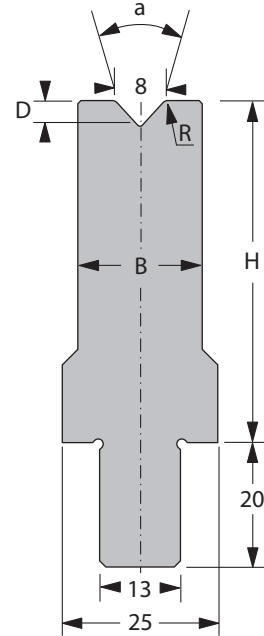
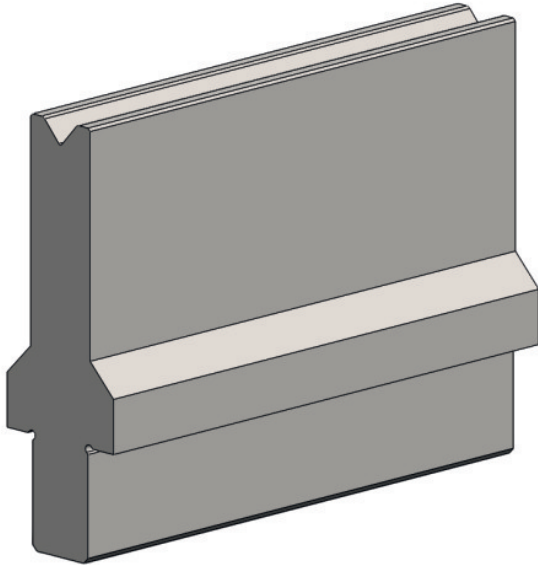

[R] Radius (mm)	1.0
[a] V - Winkel	85°
[H] Höhe (mm)	55

[B] Breite (mm)	20
[T] Tiefe (mm)	4.1

Bestell-Nr. Datenblatt OTD: 10164792

Standardlänge	Teilenummer
10 mm	64201.0008.5302
15 mm	64201.0008.5303
20 mm	64201.0008.5218
25 mm	64201.0008.5219
30 mm	64201.0008.5220
35 mm	64201.0008.5221
40 mm	64201.0008.5222
45 mm	64201.0008.5223
50 mm	64201.0008.5224
55 mm	64201.0008.5225
60 mm	64201.0008.5226
65 mm	64201.0008.5227
70 mm	64201.0008.5228
75 mm	64201.0008.5229

Standardlänge	Teilenummer
80 mm	64201.0008.5230
85 mm	64201.0008.5231
90 mm	64201.0008.5232
95 mm	64201.0008.5233
100 mm	64201.0008.5234
200 mm	64201.0008.5235
275 mm	64201.0008.5236
300 mm	64201.0008.5237
515 mm	64201.0008.5304
550 mm FSW	64201.0008.9014
1000 mm FSC	64201.0008.0034
1030 mm	64201.0008.3018



F max 90° = 850 kN/m



11.0 kg/m



Matrizeneinsatz 13 mm



V8/85° H100

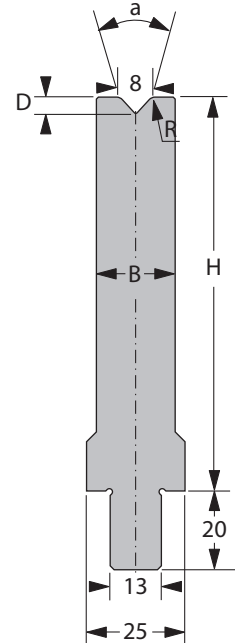
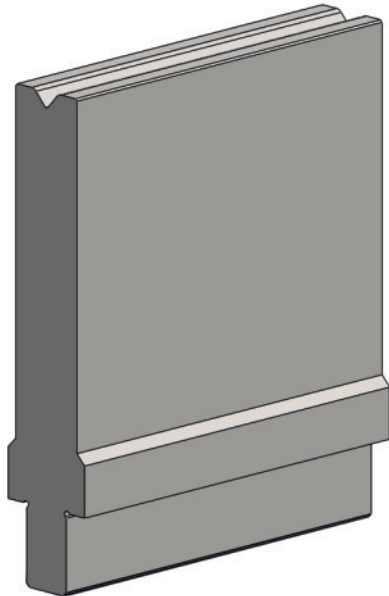

[R] Radius (mm)	1.0
[a] V - Winkel	85°
[H] Höhe (mm)	100

[B] Breite (mm)	20
[T] Tiefe (mm)	4.1
Bestell-Nr. Datenblatt OTD: 10164793	

Standardlänge	Teilenummer
10 mm	64201.0008.5238
15 mm	64201.0008.5239
20 mm	64201.0008.5240
25 mm	64201.0008.5241
30 mm	64201.0008.5242
35 mm	64201.0008.5243
40 mm	64201.0008.5244
45 mm	64201.0008.5245
50 mm	64201.0008.5246
55 mm	64201.0008.5247
60 mm	64201.0008.5248
65 mm	64201.0008.5249
70 mm	64201.0008.5250
75 mm	64201.0008.5251

Standardlänge	Teilenummer
80 mm	64201.0008.5252
85 mm	64201.0008.5253
90 mm	64201.0008.5254
95 mm	64201.0008.5255
100 mm	64201.0008.5256
200 mm	64201.0008.5257
275 mm	64201.0008.5258
300 mm	64201.0008.5259
515 mm	64201.0008.5305
550 mm FSW	64201.0008.9015
1000 mm FSC	64201.0008.0035
1030 mm	64201.0008.3015



F max 90° = 850 kN/m



18.0 kg/m



Matrizeneinsatz 13 mm



V8S/30° H55

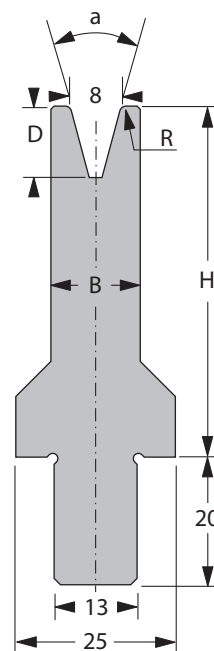
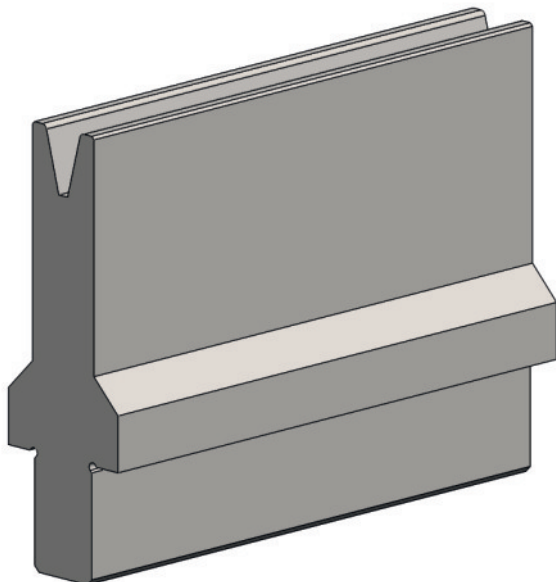

[R] Radius (mm)	1.0
[a] V - Winkel	30°
[H] Höhe (mm)	55

[B] Breite (mm)	14
[T] Tiefe (mm)	11.2

Bestell-Nr. Datenblatt OTD: 10165569

Standardlänge	Teilenummer
10 mm	64201.0008.5105
15 mm	64201.0008.5162
20 mm	64201.0008.5134
25 mm	64201.0008.5163
30 mm	64201.0008.5125
35 mm	64201.0008.5164
40 mm	64201.0008.5165
45 mm	64201.0008.5166
50 mm	64201.0008.5167
55 mm	64201.0008.5168
60 mm	64201.0008.5169
65 mm	64201.0008.5170
70 mm	64201.0008.5171
75 mm	64201.0008.5172

Standardlänge	Teilenummer
80 mm	64201.0008.5173
85 mm	64201.0008.5174
90 mm	64201.0008.5175
95 mm	64201.0008.5176
100 mm	64201.0008.5177
200 mm	64201.0008.5048
275 mm	64201.0008.5178
300 mm	64201.0008.5179
515 mm	64201.0008.5102
550 mm FSW	64201.0008.9102
1000 mm FSC	64201.0008.0101
1030 mm	64201.0008.3101



$F_{\max} 30^\circ = 110 \text{ kN/m}$
 $F_{\max} 90^\circ = 400 \text{ kN/m}$



8.7 kg/m



Matrizeneinsatz 13 mm



V8S/30° H100

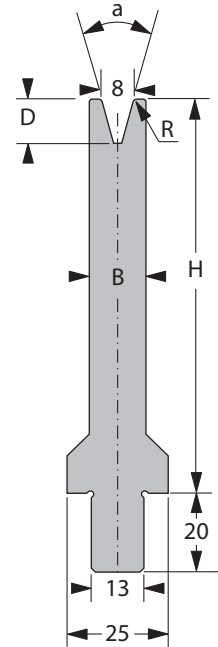
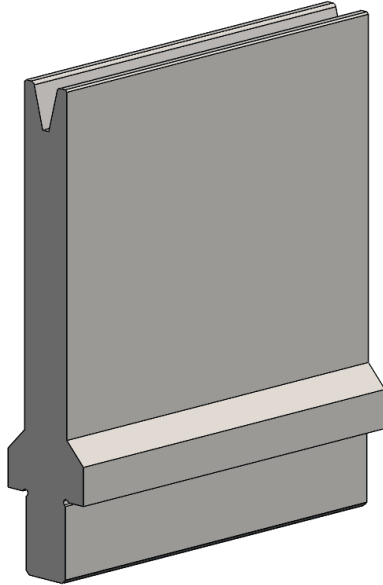

[R] Radius (mm)	1.0
[a] V - Winkel	30°
[H] Höhe (mm)	100

[B] Breite (mm)	14
[T] Tiefe (mm)	11.2
Bestell-Nr. Datenblatt OTD: 10165570	

Standardlänge	Teilenummer
10 mm	64201.0008.5199
15 mm	64201.0008.5200
20 mm	64201.0008.5201
25 mm	64201.0008.5202
30 mm	64201.0008.5140
35 mm	64201.0008.5203
40 mm	64201.0008.5204
45 mm	64201.0008.5205
50 mm	64201.0008.5139
55 mm	64201.0008.5207
60 mm	64201.0008.5208
65 mm	64201.0008.5209
70 mm	64201.0008.5210
75 mm	64201.0008.5211

Standardlänge	Teilenummer
80 mm	64201.0008.5212
85 mm	64201.0008.5213
90 mm	64201.0008.5206
95 mm	64201.0008.5214
100 mm	64201.0008.5215
200 mm	64201.0008.5080
275 mm	64201.0008.5216
300 mm	64201.0008.5079
515 mm	64201.0008.5103
550 mm FSW	64201.0008.9005
1000 mm FSC	64201.0008.0102
1030 mm	64201.0008.3114



F max 30° = 110 kN/m
F max 90° = 400 kN/m



13.7 kg/m



Matrizeneinsatz 13 mm



V8S/85° H55

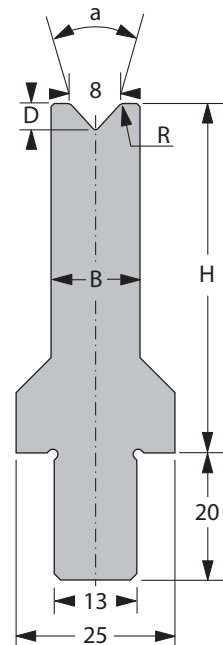
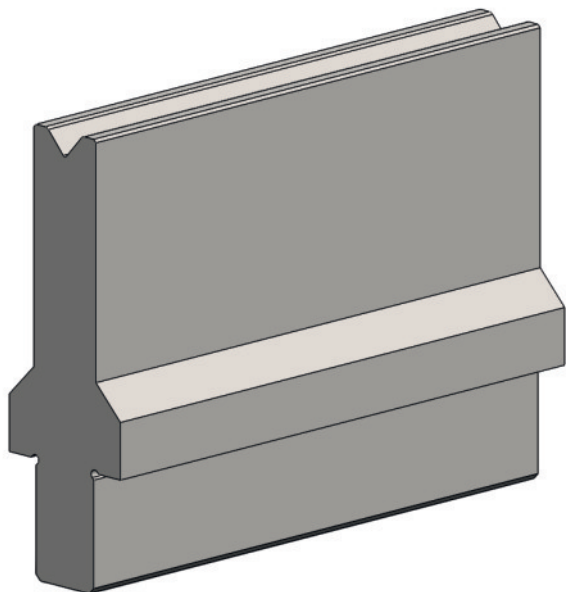

[R] Radius (mm)	1.0
[a] V - Winkel	85°
[H] Höhe (mm)	55

[B] Breite (mm)	14
[T] Tiefe (mm)	4.1

Bestell-Nr. Datenblatt OTD: 10164794

Standardlänge	Teilenummer
10 mm	64201.0008.5260
15 mm	64201.0008.5261
20 mm	64201.0008.5262
25 mm	64201.0008.5263
30 mm	64201.0008.5264
35 mm	64201.0008.5265
40 mm	64201.0008.5266
45 mm	64201.0008.5267
50 mm	64201.0008.5268
55 mm	64201.0008.5269
60 mm	64201.0008.5270
65 mm	64201.0008.5271
70 mm	64201.0008.5272
75 mm	64201.0008.5273

Standardlänge	Teilenummer
80 mm	64201.0008.5274
85 mm	64201.0008.5275
90 mm	64201.0008.5276
95 mm	64201.0008.5277
100 mm	64201.0008.5278
200 mm	64201.0008.5141
275 mm	64201.0008.5279
300 mm	64201.0008.5280
515 mm	64201.0008.5137
550 mm FSW	64201.0008.9010
1000 mm FSC	64201.0008.0027
1030 mm	64201.0008.3016



F max 90° = 800 kN/m



9.0 kg/m



Matrizeneinsatz 13 mm



V8S/85° H100

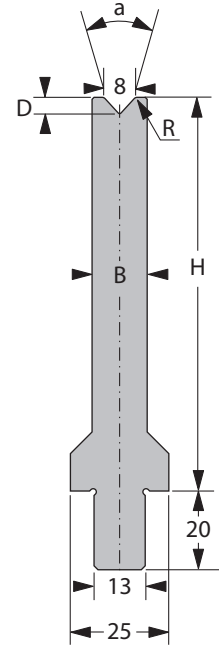
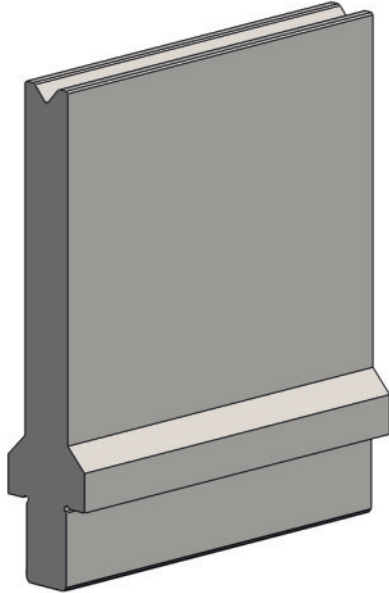

[R] Radius (mm)	1.0
[a] V - Winkel	85°
[H] Höhe (mm)	100

[B] Breite (mm)	14
[T] Tiefe (mm)	4.1
Bestell-Nr. Datenblatt OTD: 10164795	

Standardlänge	Teilenummer
10 mm	64201.0008.5281
15 mm	64201.0008.5282
20 mm	64201.0008.5283
25 mm	64201.0008.5284
30 mm	64201.0008.5285
35 mm	64201.0008.5286
40 mm	64201.0008.5287
45 mm	64201.0008.5288
50 mm	64201.0008.5289
55 mm	64201.0008.5290
60 mm	64201.0008.5291
65 mm	64201.0008.5292
70 mm	64201.0008.5293
75 mm	64201.0008.5294

Standardlänge	Teilenummer
80 mm	64201.0008.5295
85 mm	64201.0008.5296
90 mm	64201.0008.5297
95 mm	64201.0008.5298
100 mm	64201.0008.5299
200 mm	64201.0008.5074
275 mm	64201.0008.5300
300 mm	64201.0008.5301
515 mm	64201.0008.5073
550 mm FSW	64201.0008.9009
1000 mm FSC	64201.0008.0026
1030 mm	64201.0008.3017



F max 90° = 800 kN/m



14.0 kg/m



Matrizeneinsatz 13 mm



V10/30° H55

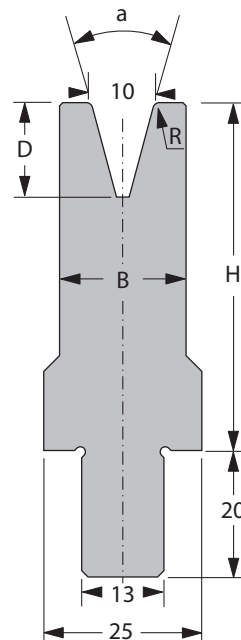
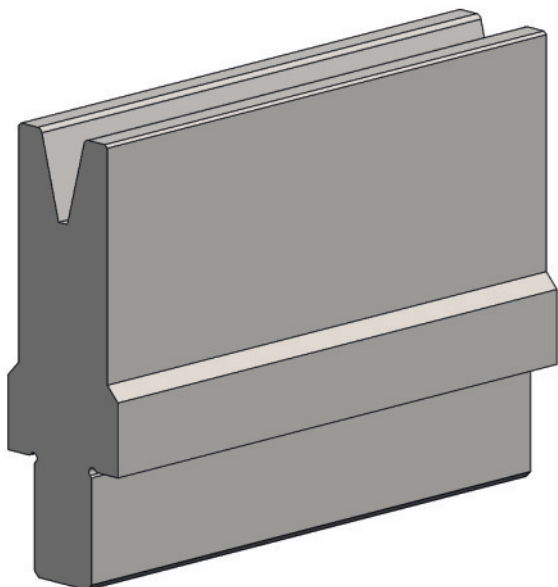

[R] Radius (mm)	1.0
[a] V - Winkel	30°
[H] Höhe (mm)	55

[B] Breite (mm)	20
[T] Tiefe (mm)	14.9

Bestell-Nr. Datenblatt OTD: 10165572

Standardlänge	Teilenummer
10 mm	64201.0010.5018
15 mm	64201.0010.5052
20 mm	64201.0010.5070
25 mm	64201.0010.5081
30 mm	64201.0010.5113
35 mm	64201.0010.5127
40 mm	64201.0010.5128
45 mm	64201.0010.5082
50 mm	64201.0010.5120
55 mm	64201.0010.5083
60 mm	64201.0010.5084
65 mm	64201.0010.5085
70 mm	64201.0010.5086
75 mm	64201.0010.5087

Standardlänge	Teilenummer
80 mm	64201.0010.5088
85 mm	64201.0010.5089
90 mm	64201.0010.5090
95 mm	64201.0010.5091
100 mm	64201.0010.5040
200 mm	64201.0010.5043
275 mm	64201.0010.5059
300 mm	64201.0010.5056
515 mm	64201.0010.5016
550 mm FSW	64201.0010.9001
1000 mm FSC	64201.0010.0004
1030 mm	64201.0010.3006



F max 30° = 200 kN/m
F max 90° = 700 kN/m



10.6 kg/m



Matrizeneinsatz 13 mm



V10/30° H100

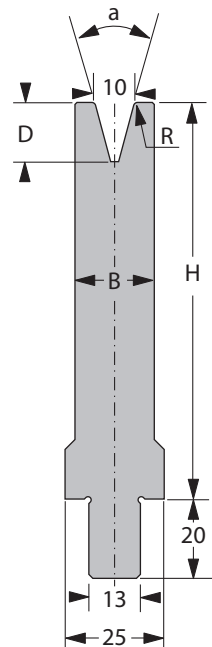
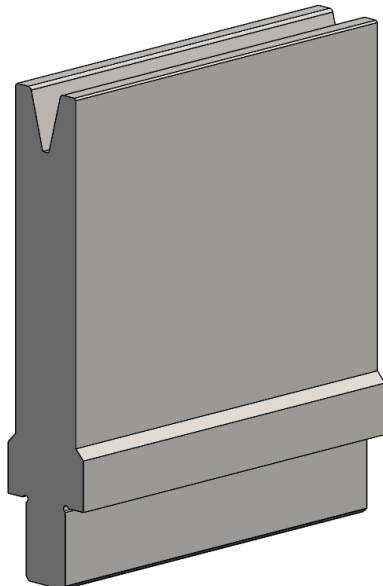

[R] Radius (mm)	1.0
[a] V - Winkel	30°
[H] Höhe (mm)	100

[B] Breite (mm)	20
[T] Tiefe (mm)	14.9
Bestell-Nr. Datenblatt OTD: 10165573	

Standardlänge	Teilenummer
10 mm	64201.0010.5076
15 mm	64201.0010.5077
20 mm	64201.0010.5066
25 mm	64201.0010.5092
30 mm	64201.0010.5078
35 mm	64201.0010.5093
40 mm	64201.0010.5094
45 mm	64201.0010.5095
50 mm	64201.0010.5079
55 mm	64201.0010.5096
60 mm	64201.0010.5097
65 mm	64201.0010.5098
70 mm	64201.0010.5099
75 mm	64201.0010.5100

Standardlänge	Teilenummer
80 mm	64201.0010.5148
85 mm	64201.0010.5149
90 mm	64201.0010.5150
95 mm	64201.0010.5151
100 mm	64201.0010.5027
200 mm	64201.0010.5044
275 mm	64201.0010.5080
300 mm	64201.0010.5057
515 mm	64201.0010.5022
550 mm FSW	64201.0010.9002
1000 mm FSC	64201.0010.0008
1030 mm	64201.0010.3008



F max 30° = 200 kN/m
F max 90° = 700 kN/m



17.6 kg/m



Matrizeneinsatz 13 mm



V10/85° H55

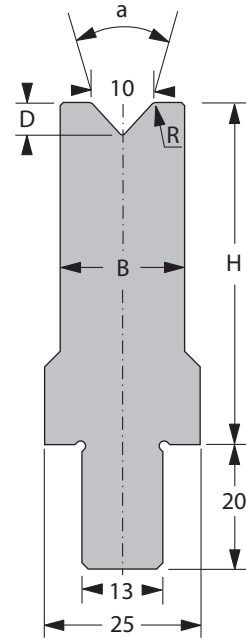
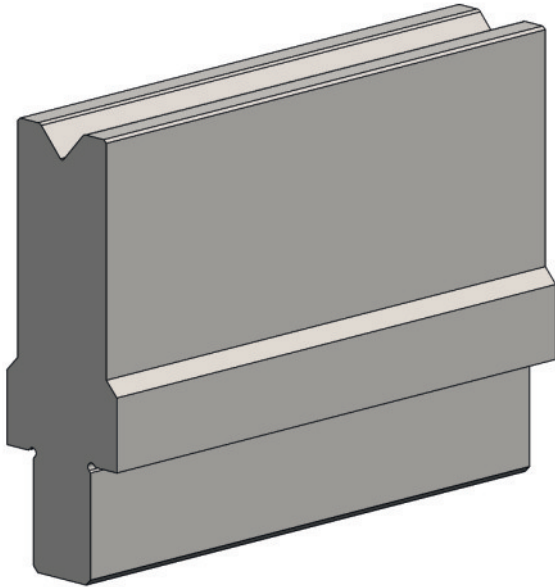

[R] Radius (mm)	1.0
[a] V - Winkel	85°
[H] Höhe (mm)	55

[B] Breite (mm)	20
[T] Tiefe (mm)	5.2

Bestell-Nr. Datenblatt OTD: 10164796

Standardlänge	Teilenummer
10 mm	64201.0010.5217
15 mm	64201.0010.5218
20 mm	64201.0010.5219
25 mm	64201.0010.5220
30 mm	64201.0010.5221
35 mm	64201.0010.5222
40 mm	64201.0010.5223
45 mm	64201.0010.5224
50 mm	64201.0010.5225
55 mm	64201.0010.5226
60 mm	64201.0010.5227
65 mm	64201.0010.5228
70 mm	64201.0010.5229
75 mm	64201.0010.5230

Standardlänge	Teilenummer
80 mm	64201.0010.5231
85 mm	64201.0010.5232
90 mm	64201.0010.5233
95 mm	64201.0010.5234
100 mm	64201.0010.5235
200 mm	64201.0010.5236
275 mm	64201.0010.5237
300 mm	64201.0010.5238
515 mm	64201.0010.5017
550 mm FSW	64201.0010.9010
1000 mm FSC	64201.0010.0010
1030 mm	64201.0010.3009



F max 90° = 800 kN/m



10.6 kg/m



Matrizeneinsatz 13 mm



V10/85° H100

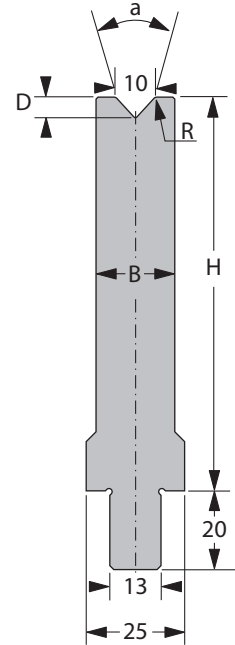
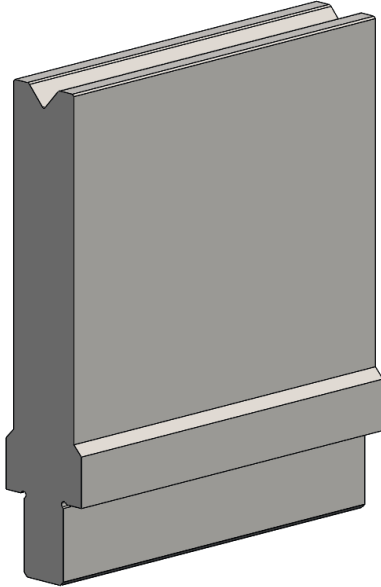

[R] Radius (mm)	1.0
[a] V - Winkel	85°
[H] Höhe (mm)	100

[B] Breite (mm)	20
[T] Tiefe (mm)	5.2
Bestell-Nr. Datenblatt OTD: 10164797	

Standardlänge	Teilenummer
10 mm	64201.0010.5239
15 mm	64201.0010.5240
20 mm	64201.0010.5241
25 mm	64201.0010.5242
30 mm	64201.0010.5243
35 mm	64201.0010.5244
40 mm	64201.0010.5245
45 mm	64201.0010.5246
50 mm	64201.0010.5247
55 mm	64201.0010.5248
60 mm	64201.0010.5249
65 mm	64201.0010.5250
70 mm	64201.0010.5251
75 mm	64201.0010.5252

Standardlänge	Teilenummer
80 mm	64201.0010.5253
85 mm	64201.0010.5254
90 mm	64201.0010.5255
95 mm	64201.0010.5256
100 mm	64201.0010.5257
200 mm	64201.0010.5258
275 mm	64201.0010.5259
300 mm	64201.0010.5260
515 mm	64201.0010.5054
550 mm FSW	64201.0010.9005
1000 mm FSC	64201.0010.0018
1030 mm	64201.0010.3017



$F_{max} 90^\circ = 800 \text{ kN/m}$



17.9 kg/m



Matrizeneinsatz 13 mm



V10S/30° H55

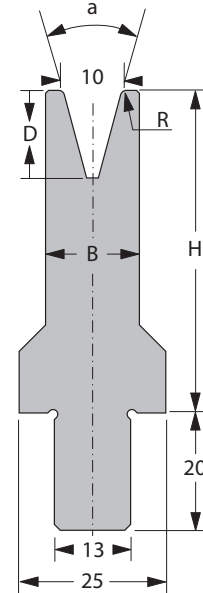
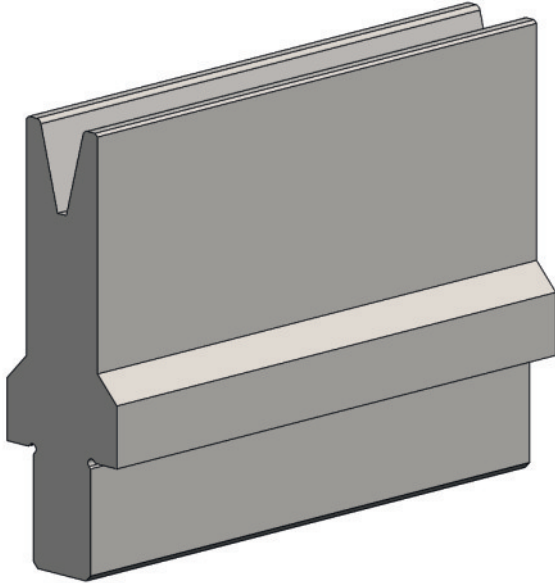

[R] Radius (mm)	1.0
[a] V - Winkel	30°
[H] Höhe (mm)	55

[B] Breite (mm)	16
[T] Tiefe (mm)	14.9

Bestell-Nr. Datenblatt OTD: 10165578

Standardlänge	Teilenummer
10 mm	64201.0010.5172
15 mm	64201.0010.5130
20 mm	64201.0010.5131
25 mm	64201.0010.5132
30 mm	64201.0010.5133
35 mm	64201.0010.5134
40 mm	64201.0010.5135
45 mm	64201.0010.5136
50 mm	64201.0010.5137
55 mm	64201.0010.5138
60 mm	64201.0010.5139
65 mm	64201.0010.5140
70 mm	64201.0010.5141
75 mm	64201.0010.5142

Standardlänge	Teilenummer
80 mm	64201.0010.5143
85 mm	64201.0010.5144
90 mm	64201.0010.5145
95 mm	64201.0010.5146
100 mm	64201.0010.5111
200 mm	64201.0010.5121
275 mm	64201.0010.5152
300 mm	64201.0010.5153
515 mm	64201.0010.5101
550 mm FSW	64201.0010.9102
1000 mm FSC	64201.0010.0101
1030 mm	64201.0010.3104



$F_{\max} 30^\circ = 100 \text{ kN/m}$
 $F_{\max} 90^\circ = 350 \text{ kN/m}$



9.1 kg/m



Matrizeneinsatz 13 mm



V10S/30° H100

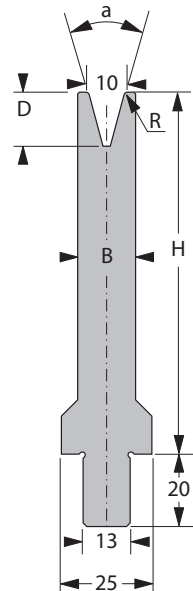
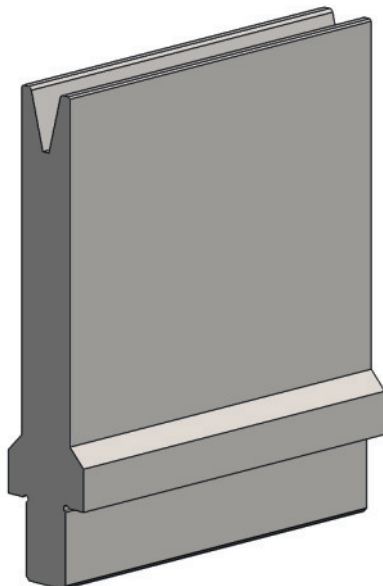

[R] Radius (mm)	1.0
[a] V - Winkel	30°
[H] Höhe (mm)	100

[B] Breite (mm)	16
[T] Tiefe (mm)	14.9
Bestell-Nr. Datenblatt OTD: 10165583	

Standardlänge	Teilenummer
10 mm	64201.0010.5154
15 mm	64201.0010.5155
20 mm	64201.0010.5156
25 mm	64201.0010.5157
30 mm	64201.0010.5063
35 mm	64201.0010.5158
40 mm	64201.0010.5159
45 mm	64201.0010.5160
50 mm	64201.0010.5161
55 mm	64201.0010.5162
60 mm	64201.0010.5163
65 mm	64201.0010.5164
70 mm	64201.0010.5165
75 mm	64201.0010.5166

Standardlänge	Teilenummer
80 mm	64201.0010.5167
85 mm	64201.0010.5168
90 mm	64201.0010.5169
95 mm	64201.0010.5170
100 mm	64201.0010.5112
200 mm	64201.0010.5062
275 mm	64201.0010.5171
300 mm	64201.0010.5125
515 mm	64201.0010.5103
550 mm FSW	64201.0010.9103
1000 mm FSC	64201.0010.0103
1030 mm	64201.0010.3109



F max 30° = 100 kN/m
F max 90° = 350 kN/m



14.7 kg/m



Matrizeneinsatz 13 mm



V10S/85° H55

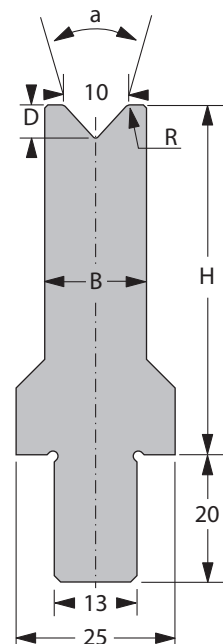
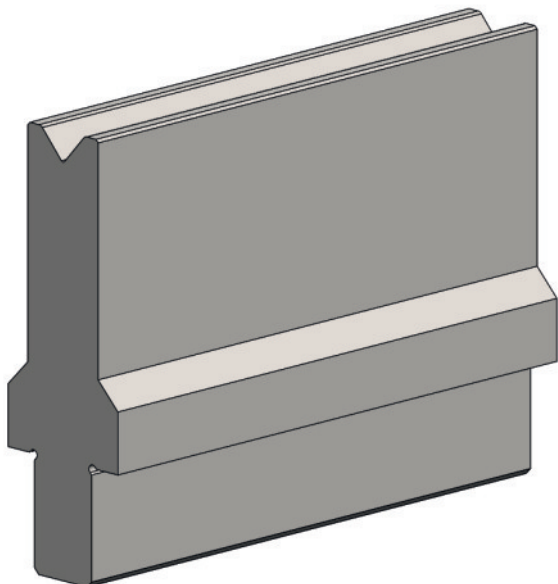

[R] Radius (mm)	1.0
[a] V - Winkel	85°
[H] Höhe (mm)	55

[B] Breite (mm)	16
[T] Tiefe (mm)	5.2

Bestell-Nr. Datenblatt OTD: 10164798

Standardlänge	Teilenummer
10 mm	64201.0010.5175
15 mm	64201.0010.5176
20 mm	64201.0010.5177
25 mm	64201.0010.5178
30 mm	64201.0010.5179
35 mm	64201.0010.5180
40 mm	64201.0010.5181
45 mm	64201.0010.5182
50 mm	64201.0010.5183
55 mm	64201.0010.5184
60 mm	64201.0010.5185
65 mm	64201.0010.5186
70 mm	64201.0010.5187
75 mm	64201.0010.5188

Standardlänge	Teilenummer
80 mm	64201.0010.5189
85 mm	64201.0010.5190
90 mm	64201.0010.5191
95 mm	64201.0010.5192
100 mm	64201.0010.5193
200 mm	64201.0010.5122
275 mm	64201.0010.5194
300 mm	64201.0010.5195
515 mm	64201.0010.5104
550 mm FSW	64201.0010.9008
1000 mm FSC	64201.0010.0110
1030 mm	64201.0010.3103



F max 90° = 700 kN/m



9.6 kg/m



Matrizeneinsatz 13 mm



V10S/85° H100

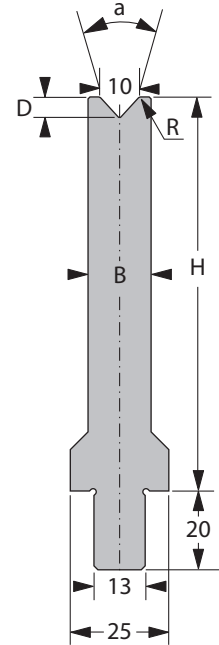
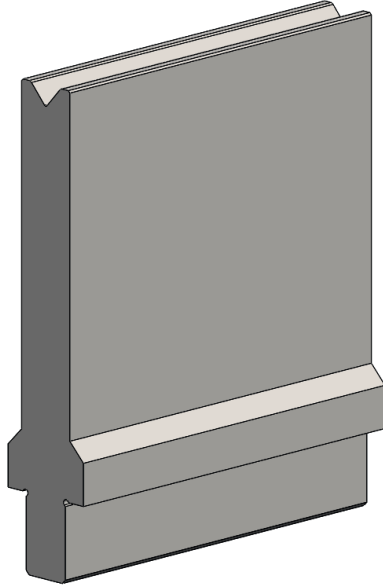

[R] Radius (mm)	1.0
[a] V - Winkel	85°
[H] Höhe (mm)	100

[B] Breite (mm)	16
[T] Tiefe (mm)	5.2
Bestell-Nr. Datenblatt OTD: 10164799	

Standardlänge	Teilenummer
10 mm	64201.0010.5196
15 mm	64201.0010.5197
20 mm	64201.0010.5198
25 mm	64201.0010.5199
30 mm	64201.0010.5200
35 mm	64201.0010.5201
40 mm	64201.0010.5202
45 mm	64201.0010.5203
50 mm	64201.0010.5204
55 mm	64201.0010.5205
60 mm	64201.0010.5206
65 mm	64201.0010.5207
70 mm	64201.0010.5208
75 mm	64201.0010.5209

Standardlänge	Teilenummer
80 mm	64201.0010.5210
85 mm	64201.0010.5211
90 mm	64201.0010.5212
95 mm	64201.0010.5213
100 mm	64201.0010.5214
200 mm	64201.0010.5061
275 mm	64201.0010.5215
300 mm	64201.0010.5216
515 mm	64201.0010.5060
550 mm FSW	64201.0010.9007
1000 mm FSC	64201.0010.0024
1030 mm	64201.0010.3110



F max 90° = 700 kN/m



15.2 kg/m



Matrizeneinsatz 13 mm



V12/30° H55

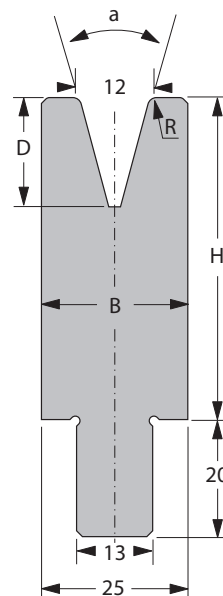
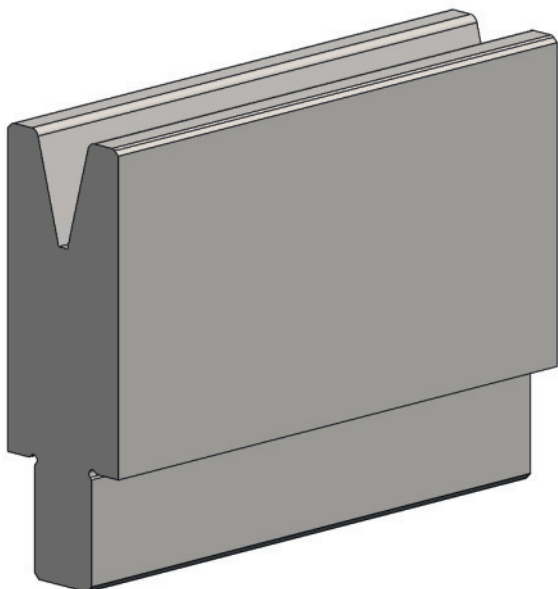

[R] Radius (mm)	1.5
[a] V - Winkel	30°
[H] Höhe (mm)	55

[B] Breite (mm)	25
[T] Tiefe (mm)	18.6

Bestell-Nr. Datenblatt OTD: 10165584

Standardlänge	Teilenummer
10 mm	64201.0012.5018
15 mm	64201.0012.5072
20 mm	64201.0012.5126
25 mm	64201.0012.5059
30 mm	64201.0012.5051
35 mm	64201.0012.5056
40 mm	64201.0012.5057
45 mm	64201.0012.5058
50 mm	64201.0012.5124
55 mm	64201.0012.5151
60 mm	64201.0012.5070
65 mm	64201.0012.5152
70 mm	64201.0012.5153
75 mm	64201.0012.5154

Standardlänge	Teilenummer
80 mm	64201.0012.5155
85 mm	64201.0012.5156
90 mm	64201.0012.5157
95 mm	64201.0012.5158
100 mm	64201.0012.5122
200 mm	64201.0012.5043
275 mm	64201.0012.5098
300 mm	64201.0012.5055
515 mm	64201.0012.5007
550 mm FSW	64201.0012.9001
1000 mm FSC	64201.0012.0002
1030 mm	64201.0012.3009



$F_{\max} 30^\circ = 250 \text{ kN/m}$
 $F_{\max} 90^\circ = 850 \text{ kN/m}$



11.8 kg/m



Matrizeneinsatz 13 mm



V12/30° H100

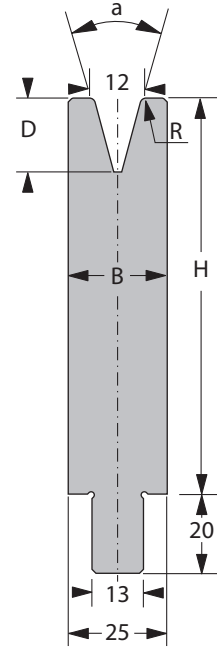
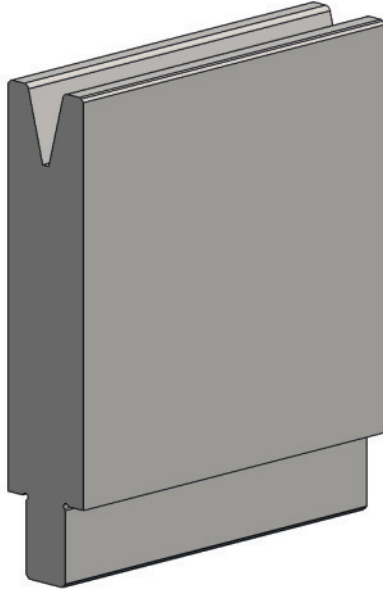

[R] Radius (mm)	1.5
[a] V - Winkel	30°
[H] Höhe (mm)	100

[B] Breite (mm)	25
[T] Tiefe (mm)	18.6
Bestell-Nr. Datenblatt OTD: 10165585	

Standardlänge	Teilenummer
10 mm	64201.0012.5089
15 mm	64201.0012.5090
20 mm	64201.0012.5136
25 mm	64201.0012.5066
30 mm	64201.0012.5067
35 mm	64201.0012.5062
40 mm	64201.0012.5063
45 mm	64201.0012.5064
50 mm	64201.0012.5065
55 mm	64201.0012.5137
60 mm	64201.0012.5138
65 mm	64201.0012.5139
70 mm	64201.0012.5140
75 mm	64201.0012.5141

Standardlänge	Teilenummer
80 mm	64201.0012.5142
85 mm	64201.0012.5143
90 mm	64201.0012.5144
95 mm	64201.0012.5145
100 mm	64201.0012.5061
200 mm	64201.0012.5044
275 mm	64201.0012.5099
300 mm	64201.0012.5060
515 mm	64201.0012.5020
550 mm FSW	64201.0012.9002
1000 mm FSC	64201.0012.0005
1030 mm	64201.0012.3013



F max 30° = 250 kN/m
F max 90° = 900 kN/m



20.6 kg/m



Matrizeneinsatz 13 mm



V12/85° H55

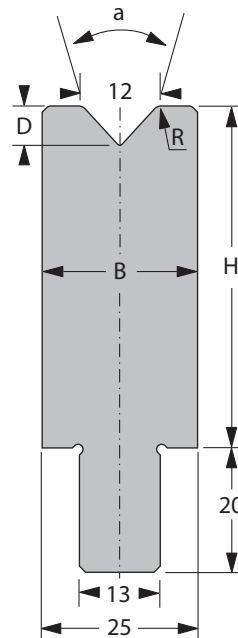
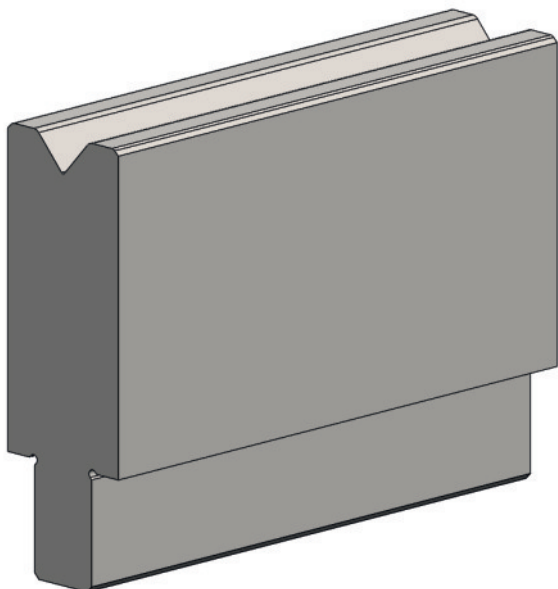

[R] Radius (mm)	1.5
[a] V - Winkel	85°
[H] Höhe (mm)	55

[B] Breite (mm)	25
[T] Tiefe (mm)	6.3

Bestell-Nr. Datenblatt OTD: 10164800

Standardlänge	Teilenummer
10 mm	64201.0012.5197
15 mm	64201.0012.5198
20 mm	64201.0012.5199
25 mm	64201.0012.5200
30 mm	64201.0012.5201
35 mm	64201.0012.5202
40 mm	64201.0012.5203
45 mm	64201.0012.5204
50 mm	64201.0012.5205
55 mm	64201.0012.5206
60 mm	64201.0012.5207
65 mm	64201.0012.5208
70 mm	64201.0012.5209
75 mm	64201.0012.5210

Standardlänge	Teilenummer
80 mm	64201.0012.5211
85 mm	64201.0012.5212
90 mm	64201.0012.5213
95 mm	64201.0012.5214
100 mm	64201.0012.5079
200 mm	64201.0012.5215
275 mm	64201.0012.5216
300 mm	64201.0012.5217
515 mm	64201.0012.5008
550 mm FSW	64201.0012.9013
1000 mm FSC	64201.0012.0007
1030 mm	64201.0012.3014



F max 90° = 900 kN/m



12.5 kg/m



Matrizeneinsatz 13 mm



V12/85° H100

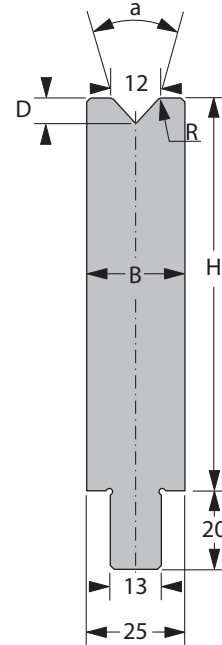
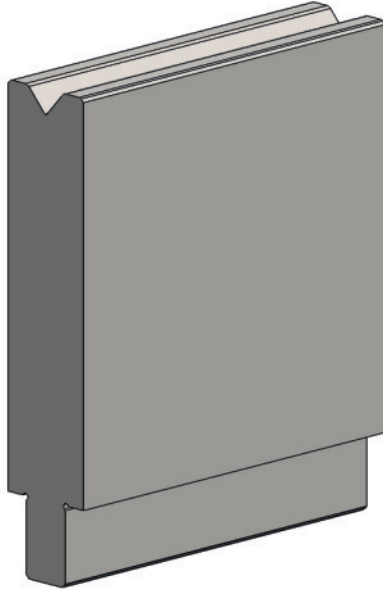

[R] Radius (mm)	1.5
[a] V - Winkel	85°
[H] Höhe (mm)	100

[B] Breite (mm)	25
[T] Tiefe (mm)	6.3
Bestell-Nr. Datenblatt OTD: 10164801	

Standardlänge	Teilenummer
10 mm	64201.0012.5218
15 mm	64201.0012.5219
20 mm	64201.0012.5220
25 mm	64201.0012.5221
30 mm	64201.0012.5222
35 mm	64201.0012.5223
40 mm	64201.0012.5224
45 mm	64201.0012.5225
50 mm	64201.0012.5226
55 mm	64201.0012.5227
60 mm	64201.0012.5228
65 mm	64201.0012.5229
70 mm	64201.0012.5230
75 mm	64201.0012.5231

Standardlänge	Teilenummer
80 mm	64201.0012.5232
85 mm	64201.0012.5233
90 mm	64201.0012.5234
95 mm	64201.0012.5235
100 mm	64201.0012.5236
200 mm	64201.0012.5237
275 mm	64201.0012.5238
300 mm	64201.0012.5239
515 mm	64201.0012.5047
550 mm FSW	64201.0012.9008
1000 mm FSC	64201.0012.0023
1030 mm	64201.0012.3025



F max 90° = 900 kN/m



21.3 kg/m



Matrizeneinsatz 13 mm



V12S/30° H55

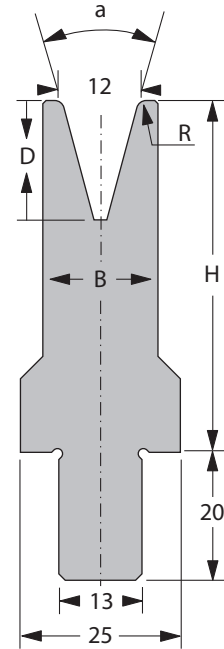
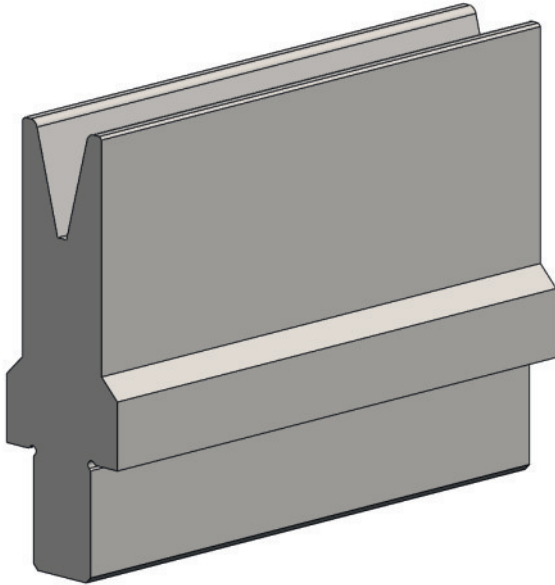

[R] Radius (mm)	1.5
[a] V - Winkel	30°
[H] Höhe (mm)	55

[B] Breite (mm)	18
[T] Tiefe (mm)	18.6

Bestell-Nr. Datenblatt OTD: 10165587

Standardlänge	Teilenummer
10 mm	64201.0012.5159
15 mm	64201.0012.5160
20 mm	64201.0012.5161
25 mm	64201.0012.5162
30 mm	64201.0012.5052
35 mm	64201.0012.5163
40 mm	64201.0012.5164
45 mm	64201.0012.5165
50 mm	64201.0012.5148
55 mm	64201.0012.5166
60 mm	64201.0012.5167
65 mm	64201.0012.5168
70 mm	64201.0012.5169
75 mm	64201.0012.5170

Standardlänge	Teilenummer
80 mm	64201.0012.5171
85 mm	64201.0012.5172
90 mm	64201.0012.5173
95 mm	64201.0012.5174
100 mm	64201.0012.5111
200 mm	64201.0012.5112
275 mm	64201.0012.5113
300 mm	64201.0012.5175
515 mm	64201.0012.5104
550 mm FSW	64201.0012.9104
1000 mm FSC	64201.0012.0101
1030 mm	64201.0012.3104



$F_{\max} 30^\circ = 100 \text{ kN/m}$
 $F_{\max} 90^\circ = 350 \text{ kN/m}$



11.8 kg/m



Matrizeneinsatz 13 mm



V12S/30° H100

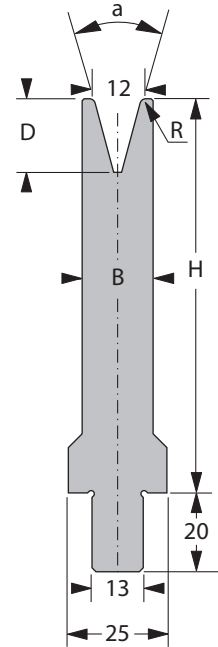
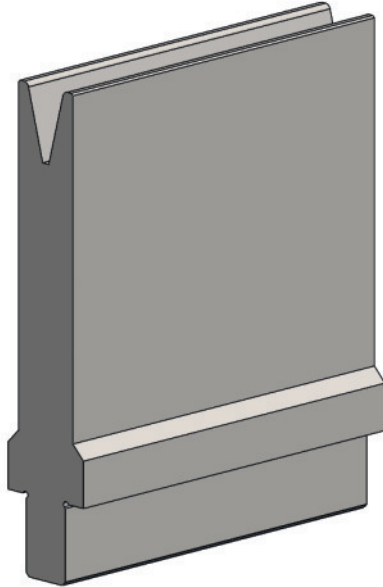

[R] Radius (mm)	1.5
[a] V - Winkel	30°
[H] Höhe (mm)	100

[B] Breite (mm)	18
[T] Tiefe (mm)	18.6
Bestell-Nr. Datenblatt OTD: 10165593	

Standardlänge	Teilenummer
10 mm	64201.0012.5176
15 mm	64201.0012.5177
20 mm	64201.0012.5178
25 mm	64201.0012.5179
30 mm	64201.0012.5180
35 mm	64201.0012.5181
40 mm	64201.0012.5182
45 mm	64201.0012.5183
50 mm	64201.0012.5069
55 mm	64201.0012.5184
60 mm	64201.0012.5185
65 mm	64201.0012.5186
70 mm	64201.0012.5187
75 mm	64201.0012.5188

Standardlänge	Teilenummer
80 mm	64201.0012.5189
85 mm	64201.0012.5190
90 mm	64201.0012.5191
95 mm	64201.0012.5192
100 mm	64201.0012.5193
200 mm	64201.0012.5131
275 mm	64201.0012.5194
300 mm	64201.0012.5092
515 mm	64201.0012.5101
550 mm FSW	64201.0012.9004
1000 mm FSC	64201.0012.0105
1030 mm	64201.0012.3111



F max 30° = 100 kN/m
F max 90° = 350 kN/m



15.9 kg/m



Matrizeneinsatz 13 mm



V12S/85° H55

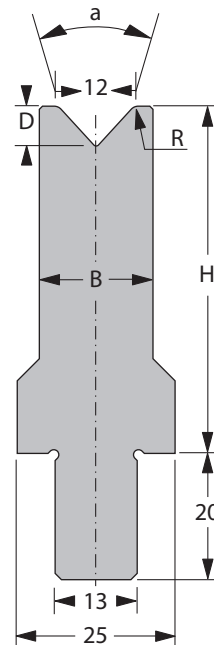
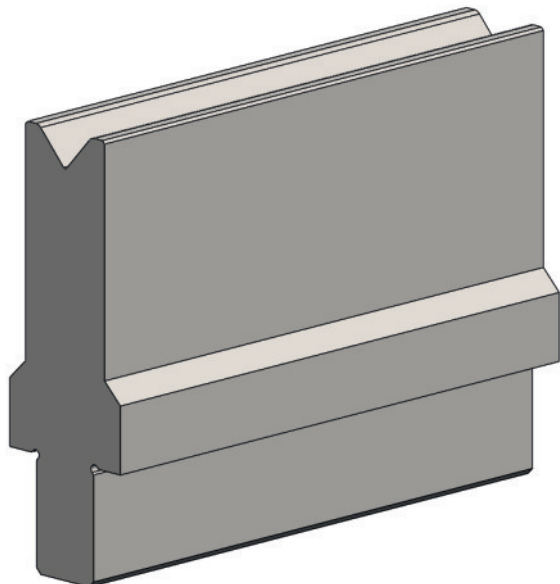

[R] Radius (mm)	1.5
[a] V - Winkel	85°
[H] Höhe (mm)	55

[B] Breite (mm)	18
[T] Tiefe (mm)	6.3

Bestell-Nr. Datenblatt OTD: 10164803

Standardlänge	Teilenummer
10 mm	64201.0012.5097
15 mm	64201.0012.5241
20 mm	64201.0012.5242
25 mm	64201.0012.5243
30 mm	64201.0012.5244
35 mm	64201.0012.5245
40 mm	64201.0012.5246
45 mm	64201.0012.5247
50 mm	64201.0012.5248
55 mm	64201.0012.5249
60 mm	64201.0012.5250
65 mm	64201.0012.5251
70 mm	64201.0012.5252
75 mm	64201.0012.5253

Standardlänge	Teilenummer
80 mm	64201.0012.5254
85 mm	64201.0012.5255
90 mm	64201.0012.5256
95 mm	64201.0012.5257
100 mm	64201.0012.5150
200 mm	64201.0012.5132
275 mm	64201.0012.5258
300 mm	64201.0012.5259
515 mm	64201.0012.5110
550 mm FSW	64201.0012.9010
1000 mm FSC	64201.0012.0108
1030 mm	64201.0012.3107



F max 90° = 700 kN/m



10.3 kg/m



Matrizeneinsatz 13 mm



V12S/85° H100

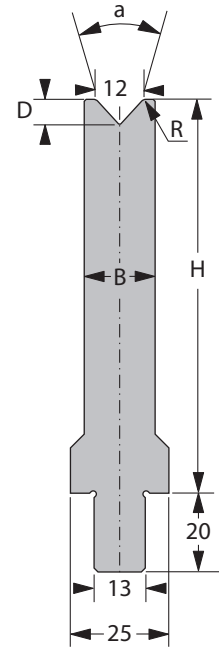
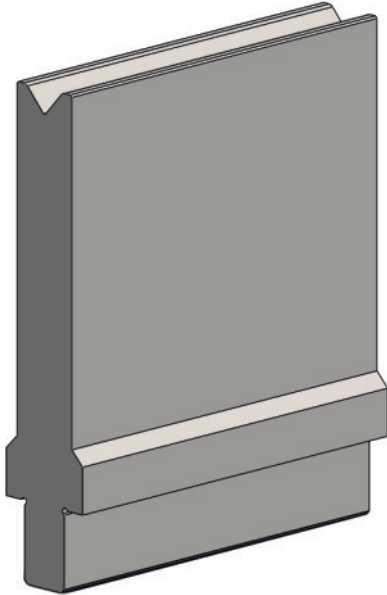

[R] Radius (mm)	1.5
[a] V - Winkel	85°
[H] Höhe (mm)	100

[B] Breite (mm)	18
[T] Tiefe (mm)	6.3
Bestell-Nr. Datenblatt OTD: 10164804	

Standardlänge	Teilenummer
10 mm	64201.0012.5260
15 mm	64201.0012.5261
20 mm	64201.0012.5262
25 mm	64201.0012.5263
30 mm	64201.0012.5264
35 mm	64201.0012.5265
40 mm	64201.0012.5266
45 mm	64201.0012.5267
50 mm	64201.0012.5268
55 mm	64201.0012.5269
60 mm	64201.0012.5270
65 mm	64201.0012.5271
70 mm	64201.0012.5272
75 mm	64201.0012.5273

Standardlänge	Teilenummer
80 mm	64201.0012.5274
85 mm	64201.0012.5275
90 mm	64201.0012.5276
95 mm	64201.0012.5277
100 mm	64201.0012.5278
200 mm	64201.0012.5088
275 mm	64201.0012.5279
300 mm	64201.0012.5280
515 mm	64201.0012.5087
550 mm FSW	64201.0012.9009
1000 mm FSC	64201.0012.0032
1030 mm	64201.0012.3116



F max 90° = 900 kN/m



16.5 kg/m



Matrizeneinsatz 13 mm



V16/30° H55

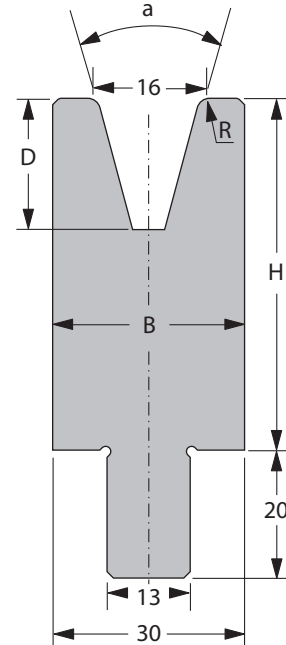
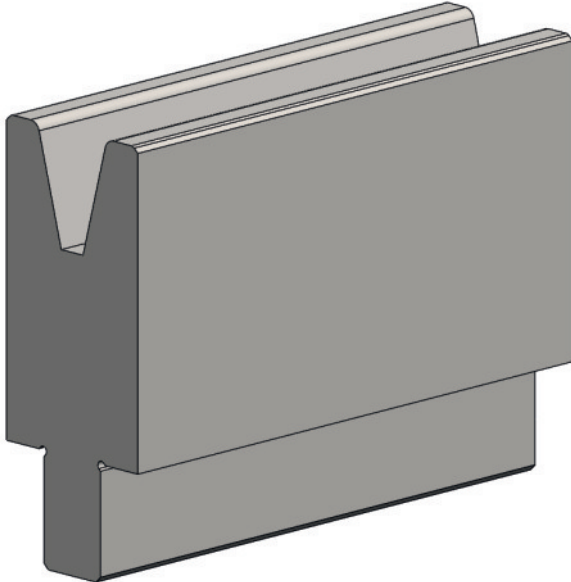

[R] Radius (mm)	2.0
[a] V - Winkel	30°
[H] Höhe (mm)	55

[B] Breite (mm)	30
[T] Tiefe (mm)	20.5

Bestell-Nr. Datenblatt OTD: 10165597

Standardlänge	Teilenummer
10 mm	64201.0016.5053
15 mm	64201.0016.5054
20 mm	64201.0016.5055
25 mm	64201.0016.5116
30 mm	64201.0016.5052
35 mm	64201.0016.5097
40 mm	64201.0016.5098
45 mm	64201.0016.5129
50 mm	64201.0016.5020
55 mm	64201.0016.5130
60 mm	64201.0016.5131
65 mm	64201.0016.5132
70 mm	64201.0016.5133
75 mm	64201.0016.5134

Standardlänge	Teilenummer
80 mm	64201.0016.5135
85 mm	64201.0016.5136
90 mm	64201.0016.5137
95 mm	64201.0016.5138
100 mm	64201.0016.5113
200 mm	64201.0016.5038
275 mm	64201.0016.5047
300 mm	64201.0016.5004
515 mm	64201.0016.5011
550 mm FSW	64201.0016.9001
1000 mm FSC	64201.0016.0001
1030 mm	64201.0016.3006



$F_{\max} 30^\circ = 300 \text{ kN/m}$
 $F_{\max} 90^\circ = 1000 \text{ kN/m}$



13.3 kg/m



Matrizeneinsatz 13 mm



V16/30° H100

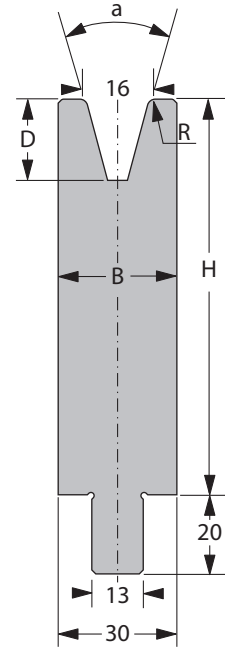
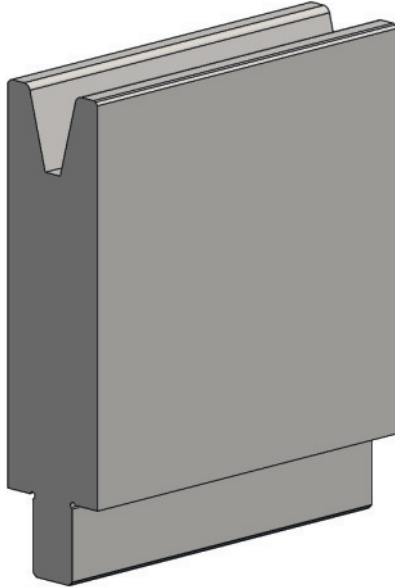

[R] Radius (mm)	2.0
[a] V - Winkel	30°
[H] Höhe (mm)	100

[B] Breite (mm)	30
[T] Tiefe (mm)	20.5
Bestell-Nr. Datenblatt OTD: 10165602	

Standardlänge	Teilenummer
10 mm	64201.0016.5100
15 mm	64201.0016.5122
20 mm	64201.0016.5123
25 mm	64201.0016.5126
30 mm	64201.0016.5124
35 mm	64201.0016.5127
40 mm	64201.0016.5073
45 mm	64201.0016.5074
50 mm	64201.0016.5069
55 mm	64201.0016.5075
60 mm	64201.0016.5076
65 mm	64201.0016.5077
70 mm	64201.0016.5078
75 mm	64201.0016.5079

Standardlänge	Teilenummer
80 mm	64201.0016.5080
85 mm	64201.0016.5081
90 mm	64201.0016.5082
95 mm	64201.0016.5083
100 mm	64201.0016.5032
200 mm	64201.0016.5039
275 mm	64201.0016.5125
300 mm	64201.0016.5128
515 mm	64201.0016.5014
550 mm FSW	64201.0016.9002
1000 mm FSC	64201.0016.0005
1030 mm	64201.0016.3022



F max 30° = 300 kN/m
F max 90° = 1000 kN/m



23.9 kg/m



Matrizeneinsatz 13 mm



V16/85° H55

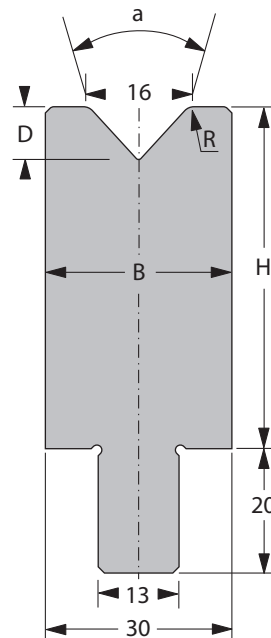
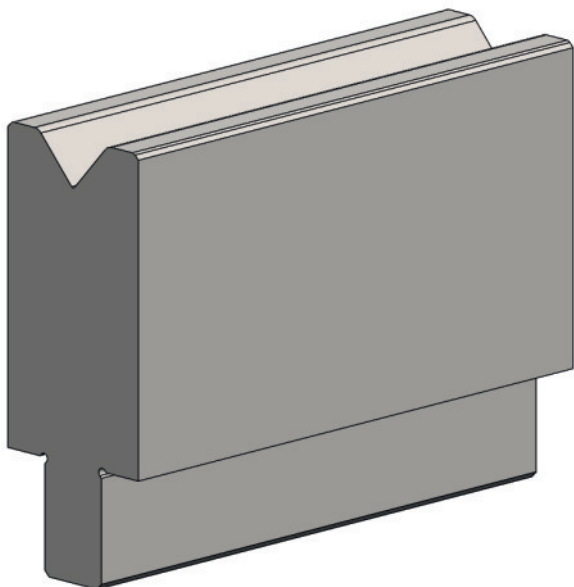

[R] Radius (mm)	2.0
[a] V - Winkel	85°
[H] Höhe (mm)	55

[B] Breite (mm)	30
[T] Tiefe (mm)	8.5

Bestell-Nr. Datenblatt OTD: 10164805

Standardlänge	Teilenummer
10 mm	64201.0016.5182
15 mm	64201.0016.5183
20 mm	64201.0016.5184
25 mm	64201.0016.5185
30 mm	64201.0016.5186
35 mm	64201.0016.5187
40 mm	64201.0016.5188
45 mm	64201.0016.5189
50 mm	64201.0016.5190
55 mm	64201.0016.5191
60 mm	64201.0016.5192
65 mm	64201.0016.5193
70 mm	64201.0016.5194
75 mm	64201.0016.5195

Standardlänge	Teilenummer
80 mm	64201.0016.5196
85 mm	64201.0016.5197
90 mm	64201.0016.5198
95 mm	64201.0016.5199
100 mm	64201.0016.5200
200 mm	64201.0016.5062
275 mm	64201.0016.5201
300 mm	64201.0016.5202
515 mm	64201.0016.5023
550 mm FSW	64201.0016.9004
1000 mm FSC	64201.0016.0009
1030 mm	64201.0016.3008



F max 90° = 1200 kN/m



14.4 kg/m



Matrizeneinsatz 13 mm



V16/85° H100

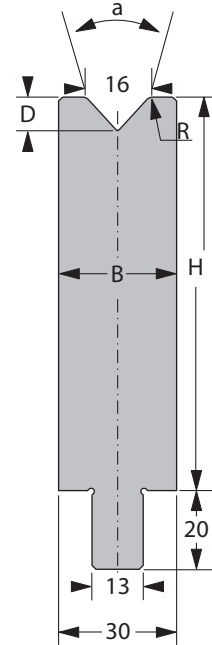
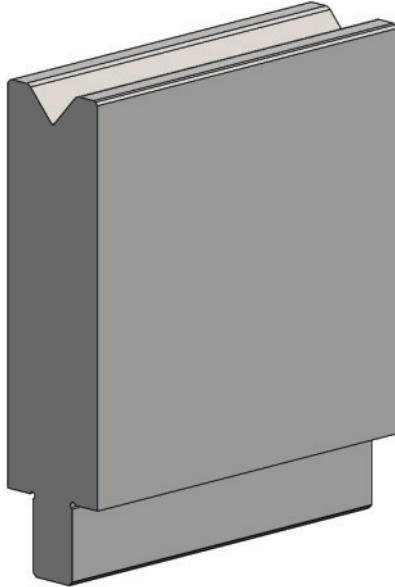

[R] Radius (mm)	2.0
[a] V - Winkel	85°
[H] Höhe (mm)	100

[B] Breite (mm)	30
[T] Tiefe (mm)	8.5
Bestell-Nr. Datenblatt OTD: 10164806	

Standardlänge	Teilenummer
10 mm	64201.0016.5203
15 mm	64201.0016.5204
20 mm	64201.0016.5119
25 mm	64201.0016.5181
30 mm	64201.0016.5205
35 mm	64201.0016.5206
40 mm	64201.0016.5207
45 mm	64201.0016.5208
50 mm	64201.0016.5209
55 mm	64201.0016.5210
60 mm	64201.0016.5211
65 mm	64201.0016.5212
70 mm	64201.0016.5213
75 mm	64201.0016.5214

Standardlänge	Teilenummer
80 mm	64201.0016.5215
85 mm	64201.0016.5216
90 mm	64201.0016.5217
95 mm	64201.0016.5218
100 mm	64201.0016.5219
200 mm	64201.0016.5220
275 mm	64201.0016.5221
300 mm	64201.0016.5222
515 mm	64201.0016.5046
550 mm FSW	64201.0016.9007
1000 mm FSC	64201.0016.0019
1030 mm	64201.0016.3023



F max 90° = 1200 kN/m



25.0 kg/m



Matrizeneinsatz 13 mm



V16S/30° H55

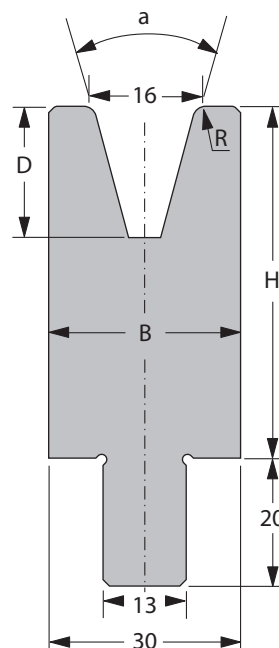
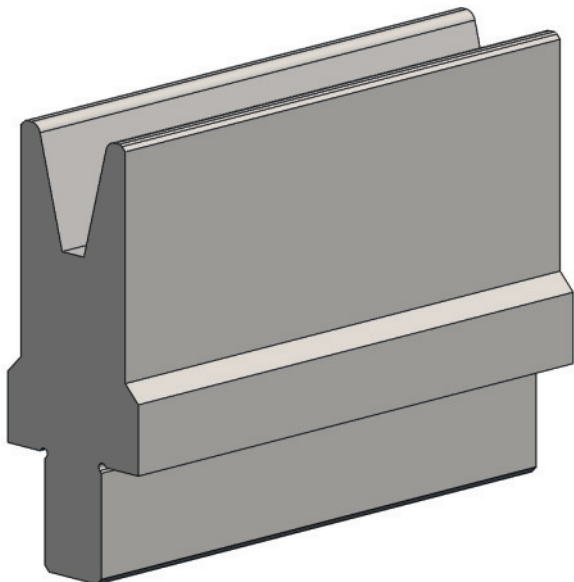

[R] Radius (mm)	2.0
[a] V - Winkel	30°
[H] Höhe (mm)	55

[B] Breite (mm)	24
[T] Tiefe (mm)	20.5

Bestell-Nr. Datenblatt OTD: 10165605

Standardlänge	Teilenummer
10 mm	64201.0016.5139
15 mm	64201.0016.5140
20 mm	64201.0016.5141
25 mm	64201.0016.5142
30 mm	64201.0016.5143
35 mm	64201.0016.5144
40 mm	64201.0016.5145
45 mm	64201.0016.5146
50 mm	64201.0016.5147
55 mm	64201.0016.5148
60 mm	64201.0016.5149
65 mm	64201.0016.5150
70 mm	64201.0016.5151
75 mm	64201.0016.5152

Standardlänge	Teilenummer
80 mm	64201.0016.5153
85 mm	64201.0016.5154
90 mm	64201.0016.5155
95 mm	64201.0016.5156
100 mm	64201.0016.5157
200 mm	64201.0016.5158
275 mm	64201.0016.5159
300 mm	64201.0016.5160
515 mm	64201.0016.5102
550 mm FSW	64201.0016.9100
1000 mm FSC	64201.0016.0104
1030 mm	64201.0016.3101



$F_{\max} 30^\circ = 150 \text{ kN/m}$
 $F_{\max} 90^\circ = 500 \text{ kN/m}$



11.3 kg/m



Matrizeneinsatz 13 mm



V16S/30° H100

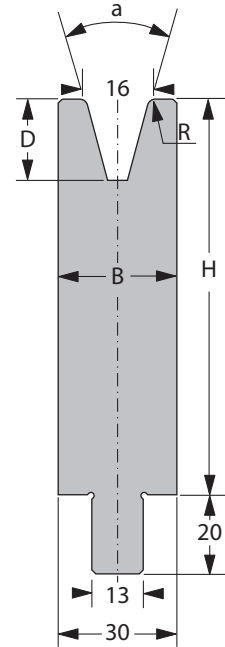
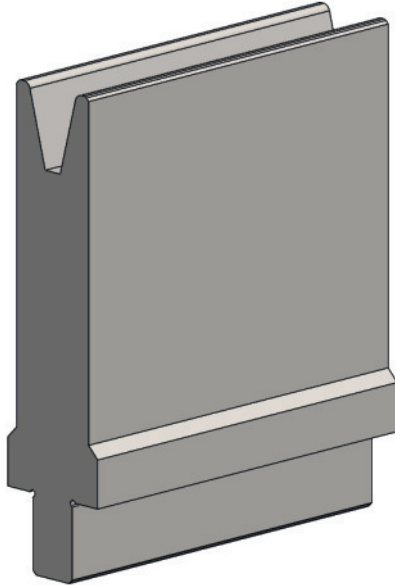

[R] Radius (mm)	2.0
[a] V - Winkel	30°
[H] Höhe (mm)	100

[B] Breite (mm)	24
[T] Tiefe (mm)	20.5
Bestell-Nr. Datenblatt OTD: 10165606	

Standardlänge	Teilenummer
10 mm	64201.0016.5161
15 mm	64201.0016.5162
20 mm	64201.0016.5163
25 mm	64201.0016.5164
30 mm	64201.0016.5165
35 mm	64201.0016.5166
40 mm	64201.0016.5167
45 mm	64201.0016.5168
50 mm	64201.0016.5169
55 mm	64201.0016.5170
60 mm	64201.0016.5171
65 mm	64201.0016.5172
70 mm	64201.0016.5173
75 mm	64201.0016.5174

Standardlänge	Teilenummer
80 mm	64201.0016.5175
85 mm	64201.0016.5176
90 mm	64201.0016.5177
95 mm	64201.0016.5178
100 mm	64201.0016.5179
200 mm	64201.0016.5064
275 mm	64201.0016.5180
300 mm	64201.0016.5063
515 mm	64201.0016.5101
550 mm FSW	64201.0016.9006
1000 mm FSC	64201.0016.0101
1030 mm	64201.0016.3109



F max 30° = 150 kN/m
F max 90° = 500 kN/m



19.8 kg/m



Matrizeneinsatz 13 mm



V16S/85° H55

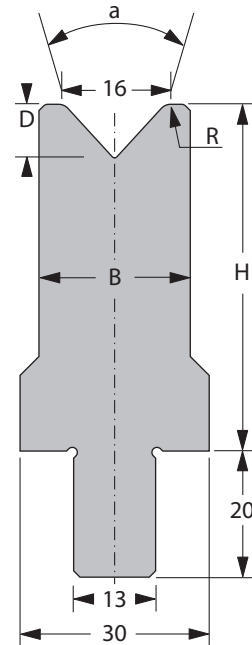
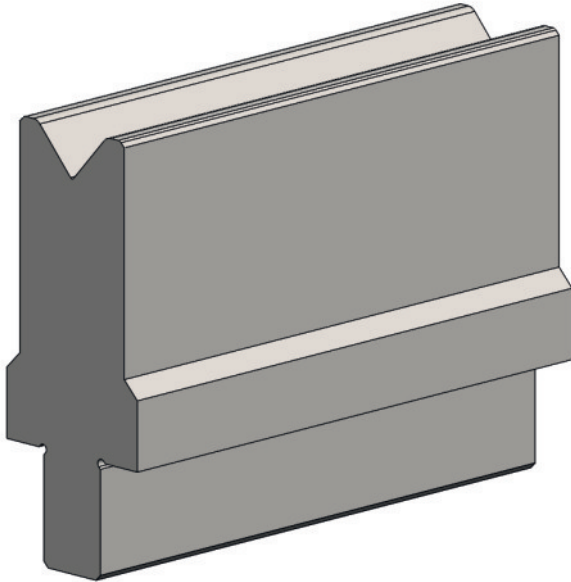

[R] Radius (mm)	2.0
[a] V - Winkel	85°
[H] Höhe (mm)	55

[B] Breite (mm)	24
[T] Tiefe (mm)	8.5

Bestell-Nr. Datenblatt OTD: 10164807

Standardlänge	Teilenummer
10 mm	64201.0016.5223
15 mm	64201.0016.5224
20 mm	64201.0016.5225
25 mm	64201.0016.5226
30 mm	64201.0016.5227
35 mm	64201.0016.5228
40 mm	64201.0016.5229
45 mm	64201.0016.5230
50 mm	64201.0016.5231
55 mm	64201.0016.5232
60 mm	64201.0016.5233
65 mm	64201.0016.5234
70 mm	64201.0016.5235
75 mm	64201.0016.5236

Standardlänge	Teilenummer
80 mm	64201.0016.5237
85 mm	64201.0016.5238
90 mm	64201.0016.5239
95 mm	64201.0016.5240
100 mm	64201.0016.5241
200 mm	64201.0016.5242
275 mm	64201.0016.5243
300 mm	64201.0016.5244
515 mm	64201.0016.5106
550 mm FSW	64201.0016.9102
1000 mm FSC	64201.0016.0105
1030 mm	64201.0016.3021



F max 90° = 1000 kN/m



12.5 kg/m



Matrizeneinsatz 13 mm



V16S/85° H100

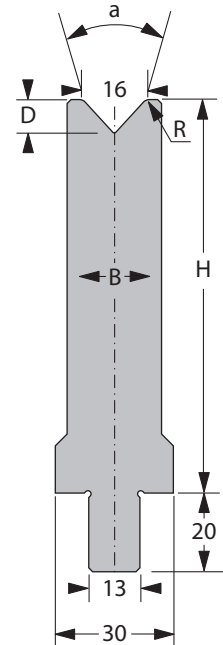
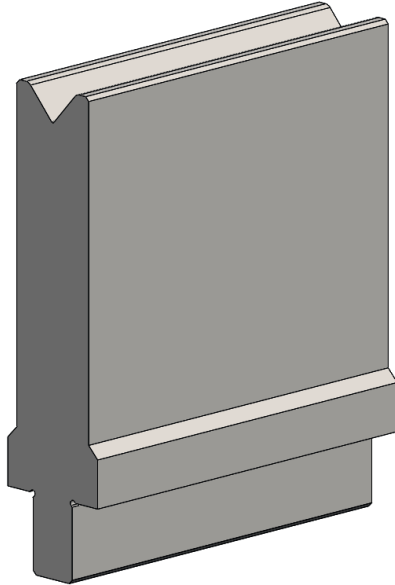

[R] Radius (mm)	2.0
[a] V - Winkel	85°
[H] Höhe (mm)	100

[B] Breite (mm)	24
[T] Tiefe (mm)	8.5
Bestell-Nr. Datenblatt OTD: 10164808	

Standardlänge	Teilenummer
10 mm	64201.0016.5245
15 mm	64201.0016.5246
20 mm	64201.0016.5247
25 mm	64201.0016.5248
30 mm	64201.0016.5249
35 mm	64201.0016.5250
40 mm	64201.0016.5251
45 mm	64201.0016.5252
50 mm	64201.0016.5253
55 mm	64201.0016.5254
60 mm	64201.0016.5255
65 mm	64201.0016.5256
70 mm	64201.0016.5257
75 mm	64201.0016.5258

Standardlänge	Teilenummer
80 mm	64201.0016.5259
85 mm	64201.0016.5260
90 mm	64201.0016.5261
95 mm	64201.0016.5262
100 mm	64201.0016.5263
200 mm	64201.0016.5264
275 mm	64201.0016.5265
300 mm	64201.0016.5266
515 mm	64201.0016.5267
550 mm FSW	64201.0016.9103
1000 mm FSC	64201.0016.0117
1030 mm	64201.0016.3110



F max 90° = 1200 kN/m



21.0 kg/m



Matrizeneinsatz 13 mm



V20/30° H55

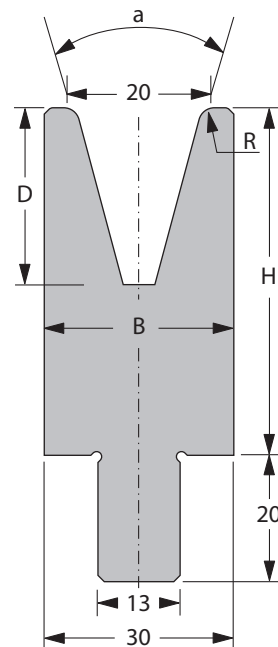
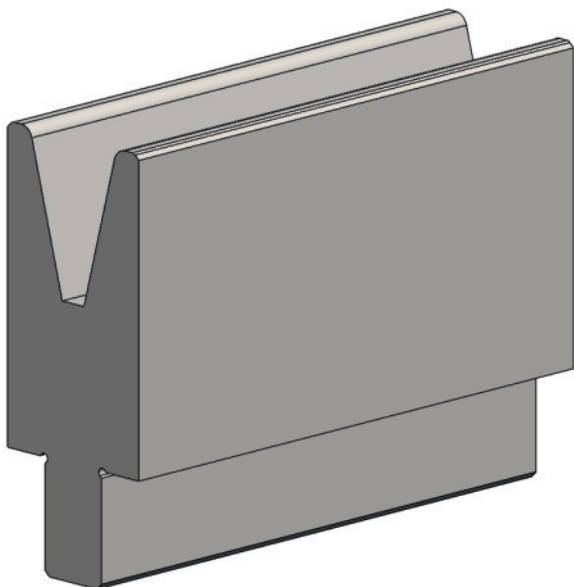

[R] Radius (mm)	2.5
[a] V - Winkel	30°
[H] Höhe (mm)	55

[B] Breite (mm)	30
[T] Tiefe (mm)	28.0

Bestell-Nr. Datenblatt OTD: 10165607

Standardlänge	Teilenummer
10 mm	64201.0020.5038
15 mm	64201.0020.5039
20 mm	64201.0020.5040
25 mm	64201.0020.5106
30 mm	64201.0020.5041
35 mm	64201.0020.5079
40 mm	64201.0020.5080
45 mm	64201.0020.5107
50 mm	64201.0020.5043
55 mm	64201.0020.5108
60 mm	64201.0020.5109
65 mm	64201.0020.5110
70 mm	64201.0020.5111
75 mm	64201.0020.5112

Standardlänge	Teilenummer
80 mm	64201.0020.5113
85 mm	64201.0020.5114
90 mm	64201.0020.5115
95 mm	64201.0020.5116
100 mm	64201.0020.5024
200 mm	64201.0020.5025
275 mm	64201.0020.5081
300 mm	64201.0020.5117
515 mm	64201.0020.5002
550 mm FSW	64201.0020.9001
1000 mm FSC	64201.0020.0002
1030 mm	64201.0020.3007



$F_{\max} 30^\circ = 180 \text{ kN/m}$
 $F_{\max} 90^\circ = 600 \text{ kN/m}$



12.2 kg/m



Matrizeneinsatz 13 mm



V20/30° H100

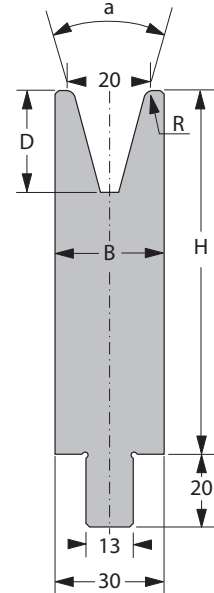
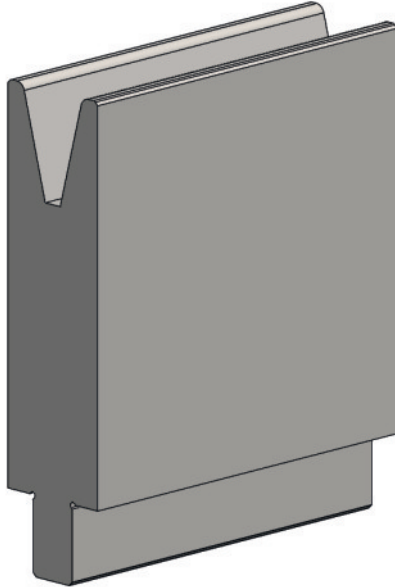

[R] Radius (mm)	2.5
[a] V - Winkel	30°
[H] Höhe (mm)	100

[B] Breite (mm)	30
[T] Tiefe (mm)	28.0
Bestell-Nr. Datenblatt OTD: 10165608	

Standardlänge	Teilenummer
10 mm	64201.0020.5083
15 mm	64201.0020.5084
20 mm	64201.0020.5085
25 mm	64201.0020.5103
30 mm	64201.0020.5034
35 mm	64201.0020.5104
40 mm	64201.0020.5054
45 mm	64201.0020.5055
50 mm	64201.0020.5056
55 mm	64201.0020.5057
60 mm	64201.0020.5058
65 mm	64201.0020.5059
70 mm	64201.0020.5060
75 mm	64201.0020.5061

Standardlänge	Teilenummer
80 mm	64201.0020.5062
85 mm	64201.0020.5063
90 mm	64201.0020.5064
95 mm	64201.0020.5065
100 mm	64201.0020.5019
200 mm	64201.0020.5026
275 mm	64201.0020.5082
300 mm	64201.0020.5105
515 mm	64201.0020.5006
550 mm FSW	64201.0020.9002
1000 mm FSC	64201.0020.0006
1030 mm	64201.0020.1008



F max 30° = 180 kN/m
F max 90° = 600 kN/m



22.8 kg/m



Matrizeneinsatz 13 mm



V20/85° H55

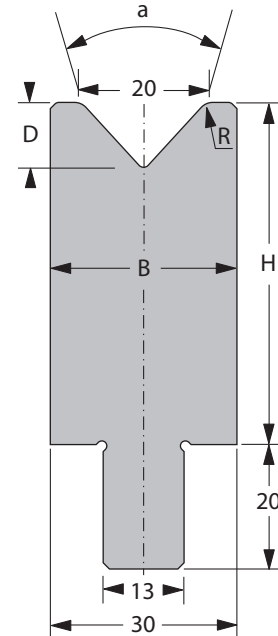
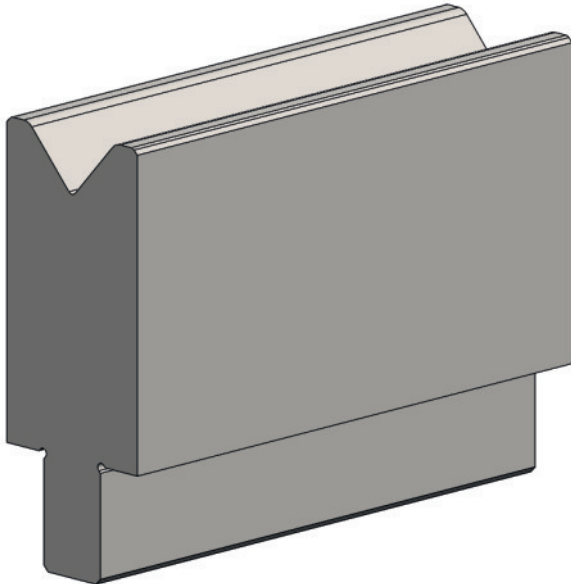

[R] Radius (mm)	2.5
[a] V - Winkel	85°
[H] Höhe (mm)	55

[B] Breite (mm)	30
[T] Tiefe (mm)	10.4

Bestell-Nr. Datenblatt OTD: 10164809

Standardlänge	Teilenummer
10 mm	64201.0020.5087
15 mm	64201.0020.5088
20 mm	64201.0020.5089
25 mm	64201.0020.5090
30 mm	64201.0020.5091
35 mm	64201.0020.5092
40 mm	64201.0020.5093
45 mm	64201.0020.5094
50 mm	64201.0020.5095
55 mm	64201.0020.5096
60 mm	64201.0020.5097
65 mm	64201.0020.5098
70 mm	64201.0020.5099
75 mm	64201.0020.5118

Standardlänge	Teilenummer
80 mm	64201.0020.5119
85 mm	64201.0020.5120
90 mm	64201.0020.5121
95 mm	64201.0020.5122
100 mm	64201.0020.5123
200 mm	64201.0020.5078
275 mm	64201.0020.5124
300 mm	64201.0020.5125
515 mm	64201.0020.5013
550 mm FSW	64201.0020.9004
1000 mm FSC	64201.0020.0009
1030 mm	64201.0020.3012



F max 90° = 1400 kN/m



14.0 kg/m



Matrizeneinsatz 13 mm



V20/85° H100

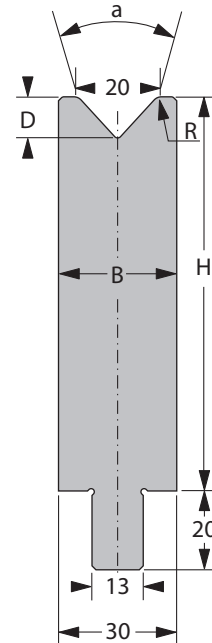
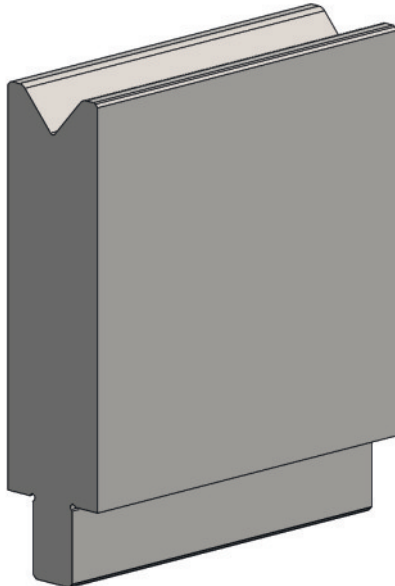

[R] Radius (mm)	2.5
[a] V - Winkel	85°
[H] Höhe (mm)	100

[B] Breite (mm)	30
[T] Tiefe (mm)	10.4
Bestell-Nr. Datenblatt OTD: 10164811	

Standardlänge	Teilenummer
10 mm	64201.0020.5126
15 mm	64201.0020.5127
20 mm	64201.0020.5128
25 mm	64201.0020.5129
30 mm	64201.0020.5130
35 mm	64201.0020.5131
40 mm	64201.0020.5132
45 mm	64201.0020.5133
50 mm	64201.0020.5134
55 mm	64201.0020.5135
60 mm	64201.0020.5136
65 mm	64201.0020.5137
70 mm	64201.0020.5138
75 mm	64201.0020.5139

Standardlänge	Teilenummer
80 mm	64201.0020.5140
85 mm	64201.0020.5141
90 mm	64201.0020.5142
95 mm	64201.0020.5143
100 mm	64201.0020.5144
200 mm	64201.0020.5145
275 mm	64201.0020.5146
300 mm	64201.0020.5147
515 mm	64201.0020.5036
550 mm FSW	64201.0020.9007
1000 mm FSC	64201.0020.0015
1030 mm	64201.0020.3014



F max 90° = 1400 kN/m



24.6 kg/m



Matrizeneinsatz 13 mm



V24/30° H55

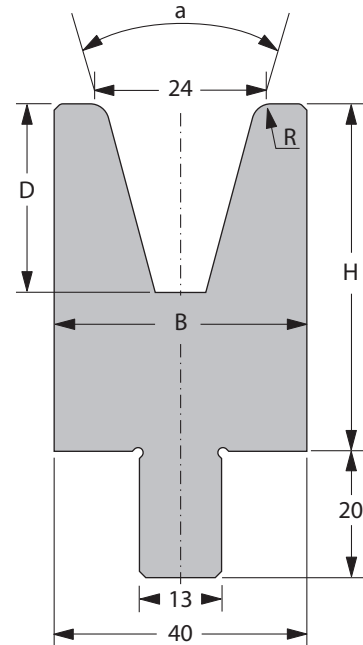
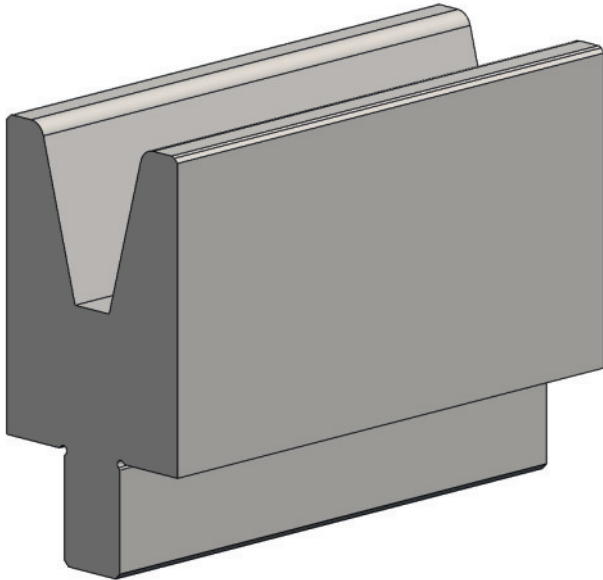

[R] Radius (mm)	3.0
[a] V - Winkel	30°
[H] Höhe (mm)	55

[B] Breite (mm)	40
[T] Tiefe (mm)	29.8

Bestell-Nr. Datenblatt OTD: 10165609

Standardlänge	Teilenummer
10 mm	64201.0024.5047
15 mm	64201.0024.5048
20 mm	64201.0024.5049
25 mm	64201.0024.5063
30 mm	64201.0024.5050
35 mm	64201.0024.5064
40 mm	64201.0024.5065
45 mm	64201.0024.5105
50 mm	64201.0024.5061
55 mm	64201.0024.5106
60 mm	64201.0024.5107
65 mm	64201.0024.5108
70 mm	64201.0024.5109
75 mm	64201.0024.5110

Standardlänge	Teilenummer
80 mm	64201.0024.5111
85 mm	64201.0024.5112
90 mm	64201.0024.5113
95 mm	64201.0024.5114
100 mm	64201.0024.5058
200 mm	64201.0024.5030
275 mm	64201.0024.5066
300 mm	64201.0024.5057
515 mm	64201.0024.5010
550 mm FSW	64201.0024.9001
1000 mm FSC	64201.0024.0001
1030 mm	64201.0024.3005



$F_{\max} 30^\circ = 330 \text{ kN/m}$
 $F_{\max} 90^\circ = 1100 \text{ kN/m}$



15.5 kg/m



Matrizeneinsatz 13 mm



V24/30° H100

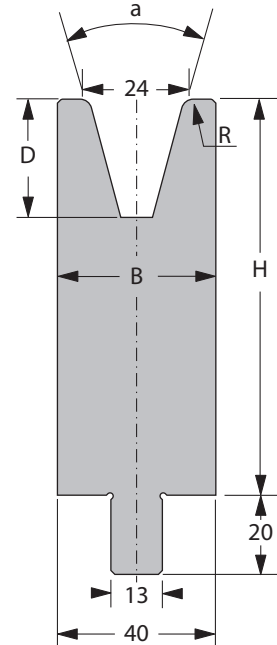
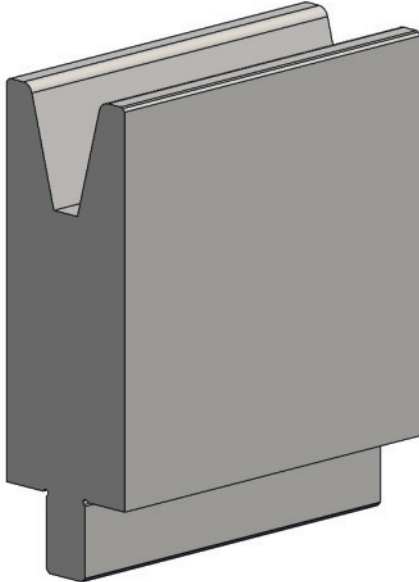

[R] Radius (mm)	3.0
[a] V - Winkel	30°
[H] Höhe (mm)	100

[B] Breite (mm)	40
[T] Tiefe (mm)	29.8

Bestell-Nr. Datenblatt OTD: 10165610

Standardlänge	Teilenummer
10 mm	64201.0024.5068
15 mm	64201.0024.5069
20 mm	64201.0024.5070
25 mm	64201.0024.5115
30 mm	64201.0024.5059
35 mm	64201.0024.5116
40 mm	64201.0024.5117
45 mm	64201.0024.5118
50 mm	64201.0024.5071
55 mm	64201.0024.5119
60 mm	64201.0024.5120
65 mm	64201.0024.5121
70 mm	64201.0024.5122
75 mm	64201.0024.5123

Standardlänge	Teilenummer
80 mm	64201.0024.5124
85 mm	64201.0024.5125
90 mm	64201.0024.5126
95 mm	64201.0024.5127
100 mm	64201.0024.5052
200 mm	64201.0024.5031
275 mm	64201.0024.5067
300 mm	64201.0024.5128
515 mm	64201.0024.5016
550 mm FSW	64201.0024.9002
1000 mm FSC	64201.0024.0007
1030 mm	64201.0024.3104



F max 30° = 330 kN/m
F max 90° = 1100 kN/m



29.6 kg/m



Matrizeneinsatz 13 mm



V24/85° H55

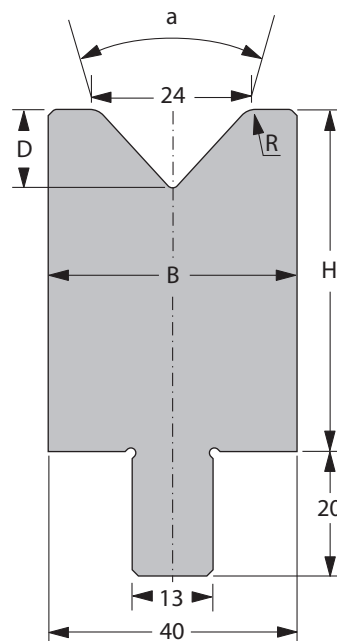
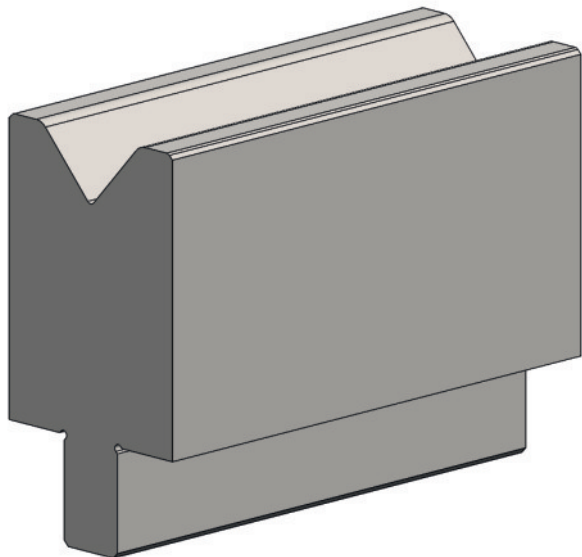

[R] Radius (mm)	3.0
[a] V - Winkel	85°
[H] Höhe (mm)	55

[B] Breite (mm)	40
[T] Tiefe (mm)	12.6

Bestell-Nr. Datenblatt OTD: 10164813

Standardlänge	Teilenummer
10 mm	64201.0024.5012
15 mm	64201.0024.5074
20 mm	64201.0024.5075
25 mm	64201.0024.5076
30 mm	64201.0024.5077
35 mm	64201.0024.5078
40 mm	64201.0024.5079
45 mm	64201.0024.5080
50 mm	64201.0024.5081
55 mm	64201.0024.5082
60 mm	64201.0024.5083
65 mm	64201.0024.5084
70 mm	64201.0024.5085
75 mm	64201.0024.5086

Standardlänge	Teilenummer
80 mm	64201.0024.5087
85 mm	64201.0024.5088
90 mm	64201.0024.5089
95 mm	64201.0024.5090
100 mm	64201.0024.5091
200 mm	64201.0024.5092
275 mm	64201.0024.5093
300 mm	64201.0024.5094
515 mm	64201.0024.5011
550 mm FSW	64201.0024.9006
1000 mm FSC	64201.0024.0002
1030 mm	64201.0024.3007



F max 90° = 1700 kN/m



18.0 kg/m



Matrizeneinsatz 13 mm



V24/85° H100

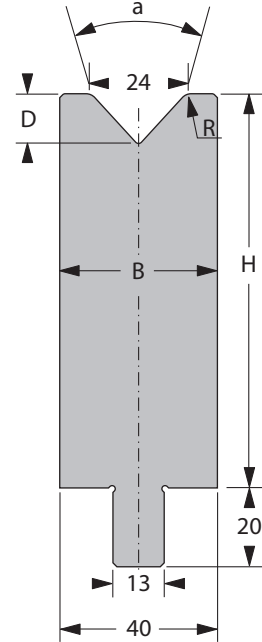
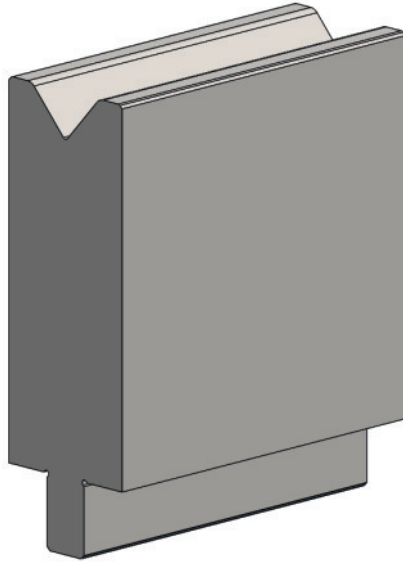

[R] Radius (mm)	3.0
[a] V - Winkel	85°
[H] Höhe (mm)	100

[B] Breite (mm)	40
[T] Tiefe (mm)	12.6

Bestell-Nr. Datenblatt OTD: 10164814

Standardlänge	Teilenummer
10 mm	64201.0024.5095
15 mm	64201.0024.5096
20 mm	64201.0024.5097
25 mm	64201.0024.5098
30 mm	64201.0024.5099
35 mm	64201.0024.5130
40 mm	64201.0024.5131
45 mm	64201.0024.5132
50 mm	64201.0024.5133
55 mm	64201.0024.5134
60 mm	64201.0024.5135
65 mm	64201.0024.5136
70 mm	64201.0024.5137
75 mm	64201.0024.5138

Standardlänge	Teilenummer
80 mm	64201.0024.5139
85 mm	64201.0024.5140
90 mm	64201.0024.5141
95 mm	64201.0024.5142
100 mm	64201.0024.5143
200 mm	64201.0024.5072
275 mm	64201.0024.5144
300 mm	64201.0024.5145
515 mm	64201.0024.5041
550 mm FSW	64201.0024.9005
1000 mm FSC	64201.0024.0013
1030 mm	64201.0024.3015



F max 90° = 1700 kN/m



32.1 kg/m



Matrizeneinsatz 13 mm



V32/30° H55

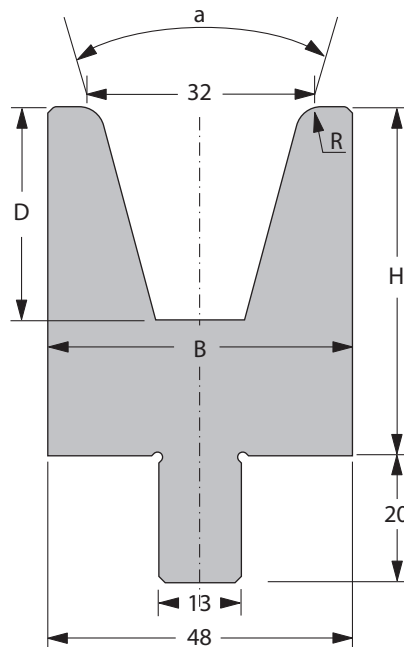
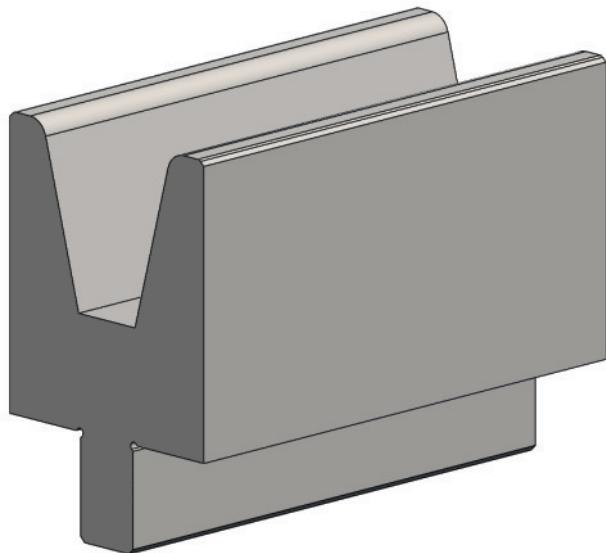

[R] Radius (mm)	4.0
[a] V - Winkel	30°
[H] Höhe (mm)	55

[B] Breite (mm)	48
[T] Tiefe (mm)	33.6

Bestell-Nr. Datenblatt OTD: 10165611

Standardlänge	Teilenummer
10 mm	64201.0032.5053
15 mm	64201.0032.5054
20 mm	64201.0032.5055
25 mm	64201.0032.5108
30 mm	64201.0032.5056
35 mm	64201.0032.5090
40 mm	64201.0032.5091
45 mm	64201.0032.5109
50 mm	64201.0032.5062
55 mm	64201.0032.5110
60 mm	64201.0032.5111
65 mm	64201.0032.5112
70 mm	64201.0032.5113
75 mm	64201.0032.5114

Standardlänge	Teilenummer
80 mm	64201.0032.5115
85 mm	64201.0032.5051
90 mm	64201.0032.5116
95 mm	64201.0032.5117
100 mm	64201.0032.5020
200 mm	64201.0032.5039
275 mm	64201.0032.5045
300 mm	64201.0032.5047
515 mm	64201.0032.5010
550 mm FSW	64201.0032.9001
1000 mm FSC	64201.0032.0002
1030 mm	64201.0032.3006



$F_{\max} 30^\circ = 340 \text{ kN/m}$
 $F_{\max} 90^\circ = 1100 \text{ kN/m}$



16.7 kg/m



Matrizeneinsatz 13 mm



V32/30° H100

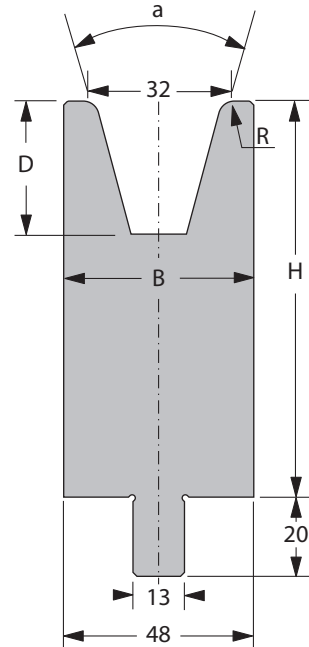
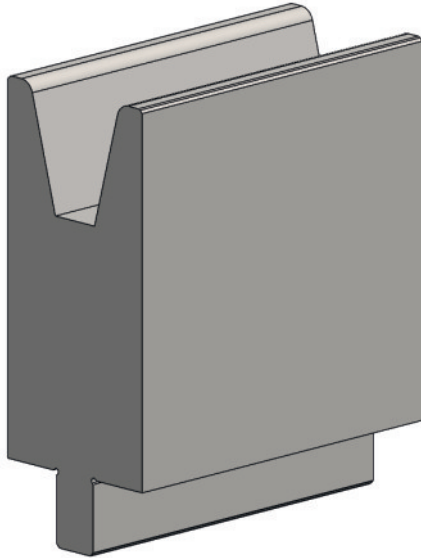

[R] Radius (mm)	4.0
[a] V - Winkel	30°
[H] Höhe (mm)	100

[B] Breite (mm)	48
[T] Tiefe (mm)	33.6

Bestell-Nr. Datenblatt OTD: 10165613

Standardlänge	Teilenummer
10 mm	64201.0032.5105
15 mm	64201.0032.5106
20 mm	64201.0032.5070
25 mm	64201.0032.5071
30 mm	64201.0032.5072
35 mm	64201.0032.5073
40 mm	64201.0032.5074
45 mm	64201.0032.5075
50 mm	64201.0032.5076
55 mm	64201.0032.5077
60 mm	64201.0032.5078
65 mm	64201.0032.5079
70 mm	64201.0032.5080
75 mm	64201.0032.5081

Standardlänge	Teilenummer
80 mm	64201.0032.5082
85 mm	64201.0032.5083
90 mm	64201.0032.5084
95 mm	64201.0032.5085
100 mm	64201.0032.5086
200 mm	64201.0032.5040
275 mm	64201.0032.5107
300 mm	64201.0032.5087
515 mm	64201.0032.5017
550 mm FSW	64201.0032.9002
1000 mm FSC	64201.0032.0008
1030 mm	64201.0032.3012



F max 30° = 340 kN/m
F max 90° = 1100 kN/m



33.7 kg/m



Matrizeneinsatz 13 mm



V32/85° H55

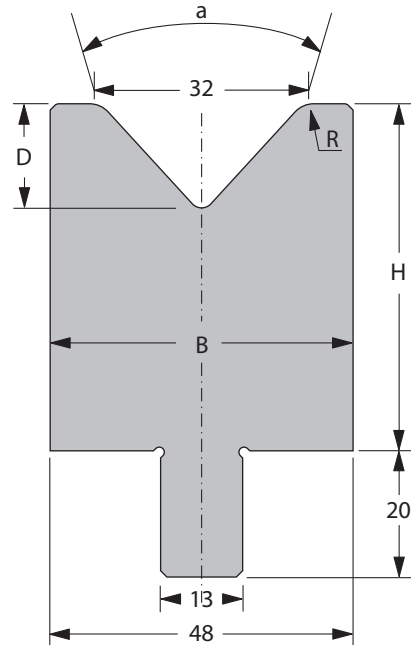
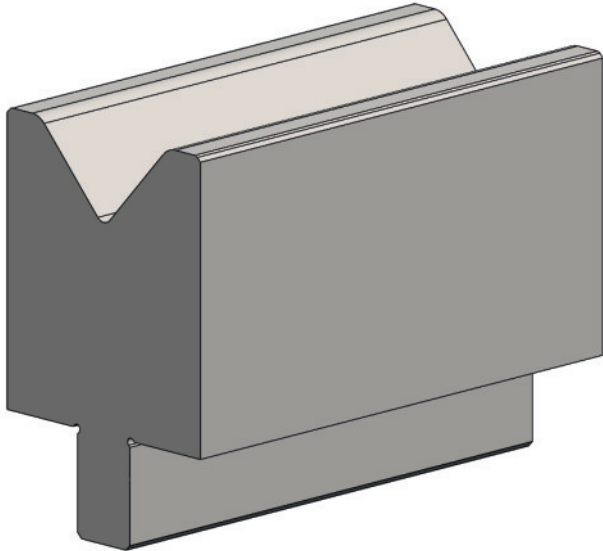

[R] Radius (mm)	4.0
[a] V - Winkel	85°
[H] Höhe (mm)	55

[B] Breite (mm)	48
[T] Tiefe (mm)	16.5

Bestell-Nr. Datenblatt OTD: 10164816

Standardlänge	Teilenummer
10 mm	64201.0032.5012
15 mm	64201.0032.5092
20 mm	64201.0032.5093
25 mm	64201.0032.5094
30 mm	64201.0032.5095
35 mm	64201.0032.5096
40 mm	64201.0032.5097
45 mm	64201.0032.5098
50 mm	64201.0032.5099
55 mm	64201.0032.5118
60 mm	64201.0032.5119
65 mm	64201.0032.5120
70 mm	64201.0032.5121
75 mm	64201.0032.5122

Standardlänge	Teilenummer
80 mm	64201.0032.5123
85 mm	64201.0032.5124
90 mm	64201.0032.5125
95 mm	64201.0032.5126
100 mm	64201.0032.5067
200 mm	64201.0032.5059
275 mm	64201.0032.5127
300 mm	64201.0032.5058
515 mm	64201.0032.5011
550 mm FSW	64201.0032.9005
1000 mm FSC	64201.0032.0003
1030 mm	64201.0032.3009



F max 90° = 2500 kN/m



20.5 kg/m



Matrizeneinsatz 13 mm



V32/85° H100

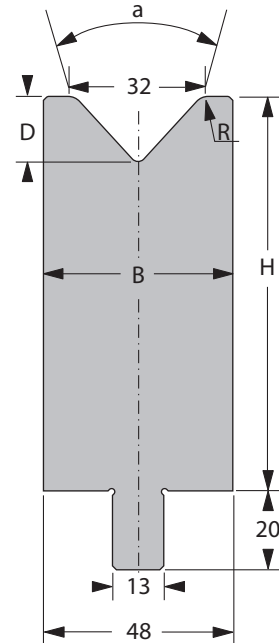
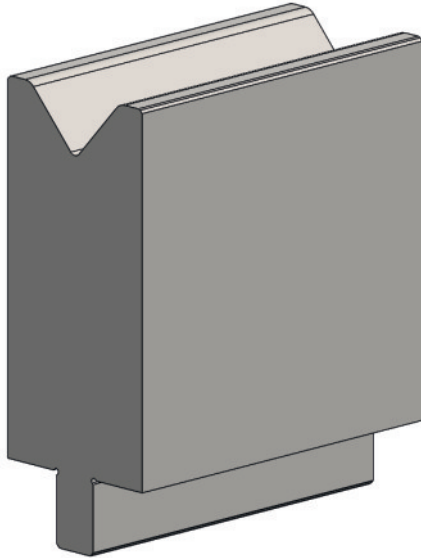

[R] Radius (mm)	4.0
[a] V - Winkel	85°
[H] Höhe (mm)	100

[B] Breite (mm)	48
[T] Tiefe (mm)	16.5

Bestell-Nr. Datenblatt OTD: 10164817

Standardlänge	Teilenummer
10 mm	64201.0032.5128
15 mm	64201.0032.5129
20 mm	64201.0032.5130
25 mm	64201.0032.5131
30 mm	64201.0032.5132
35 mm	64201.0032.5133
40 mm	64201.0032.5134
45 mm	64201.0032.5135
50 mm	64201.0032.5136
55 mm	64201.0032.5137
60 mm	64201.0032.5138
65 mm	64201.0032.5139
70 mm	64201.0032.5140
75 mm	64201.0032.5141

Standardlänge	Teilenummer
80 mm	64201.0032.5142
85 mm	64201.0032.5143
90 mm	64201.0032.5144
95 mm	64201.0032.5145
100 mm	64201.0032.5146
200 mm	64201.0032.5147
275 mm	64201.0032.5148
300 mm	64201.0032.5064
515 mm	64201.0032.5048
550 mm FSW	64201.0032.9004
1000 mm FSC	64201.0032.0014
1030 mm	64201.0032.3013



F max 90° = 2500 kN/m



37.5 kg/m



Matrizeneinsatz 13 mm



V40/60° H55

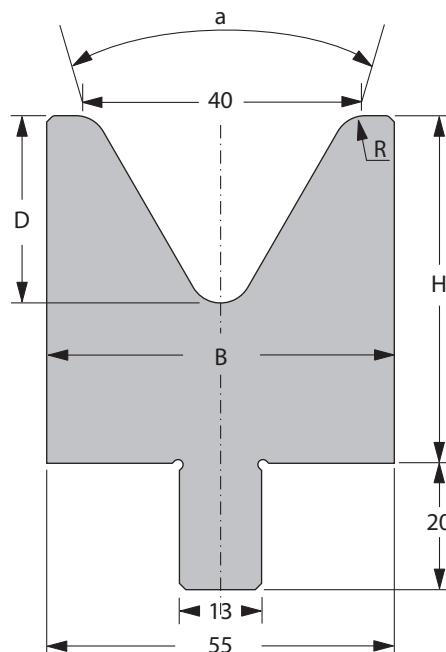
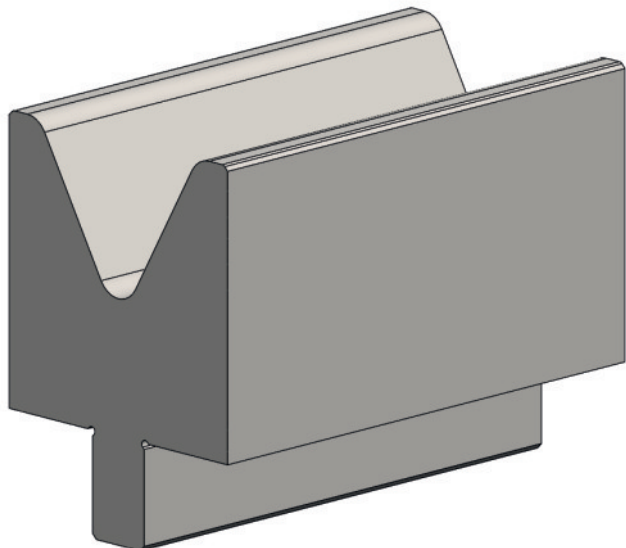

[R] Radius (mm)	5.0
[a] V - Winkel	60°
[H] Höhe (mm)	55

[B] Breite (mm)	55
[T] Tiefe (mm)	29.6

Bestell-Nr. Datenblatt OTD: 10165617

Standardlänge	Teilenummer
10 mm	64201.0040.5035
15 mm	64201.0040.5036
20 mm	64201.0040.5037
25 mm	64201.0040.5050
30 mm	64201.0040.5038
35 mm	64201.0040.5052
40 mm	64201.0040.5079
45 mm	64201.0040.5082
50 mm	64201.0040.5083
55 mm	64201.0040.5084
60 mm	64201.0040.5085
65 mm	64201.0040.5086
70 mm	64201.0040.5087
75 mm	64201.0040.5088

Standardlänge	Teilenummer
80 mm	64201.0040.5089
85 mm	64201.0040.5090
90 mm	64201.0040.5091
95 mm	64201.0040.5092
100 mm	64201.0040.5010
200 mm	64201.0040.5022
275 mm	64201.0040.5004
300 mm	64201.0040.5093
515 mm	64201.0040.5003
550 mm FSW	64201.0040.9001
1000 mm FSC	64201.0040.0002
1030 mm	64201.0040.3007



$F_{\max} 60^\circ = 1100 \text{ kN/m}$
 $F_{\max} 90^\circ = 1800 \text{ kN/m}$



20.5 kg/m



Matrizeneinsatz 13 mm



V40/60° H100

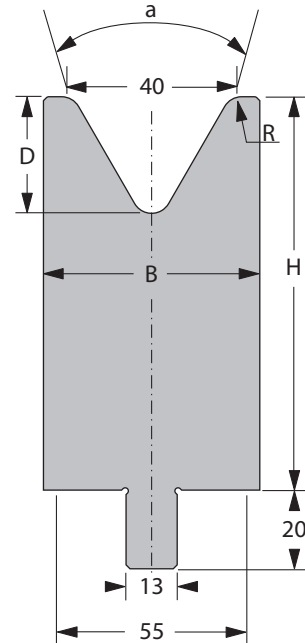
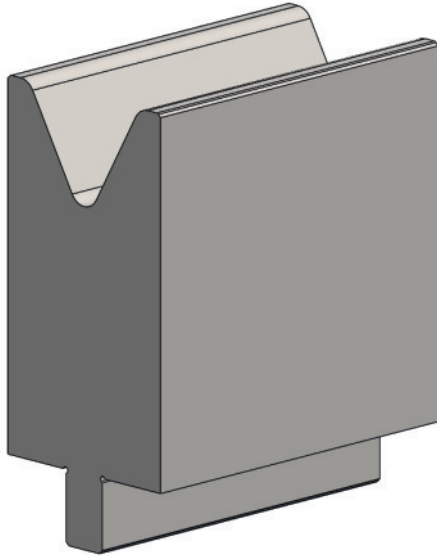

[R] Radius (mm)	5.0
[a] V - Winkel	60°
[H] Höhe (mm)	100

[B] Breite (mm)	55
[T] Tiefe (mm)	29.6

Bestell-Nr. Datenblatt OTD: 10165620

Standardlänge	Teilenummer
10 mm	64201.0040.5094
15 mm	64201.0040.5095
20 mm	64201.0040.5063
25 mm	64201.0040.5053
30 mm	64201.0040.5064
35 mm	64201.0040.5096
40 mm	64201.0040.5065
45 mm	64201.0040.5066
50 mm	64201.0040.5067
55 mm	64201.0040.5068
60 mm	64201.0040.5069
65 mm	64201.0040.5070
70 mm	64201.0040.5071
75 mm	64201.0040.5072

Standardlänge	Teilenummer
80 mm	64201.0040.5073
85 mm	64201.0040.5074
90 mm	64201.0040.5075
95 mm	64201.0040.5076
100 mm	64201.0040.5077
200 mm	64201.0040.5023
275 mm	64201.0040.5049
300 mm	64201.0040.5078
515 mm	64201.0040.5007
550 mm FSW	64201.0040.9002
1000 mm FSC	64201.0040.0004
1030 mm	64201.0040.3008



F max 60° = 1100 kN/m
F max 90° = 2000 kN/m



39.9 kg/m



Matrizeneinsatz 13 mm



V50/60° H55

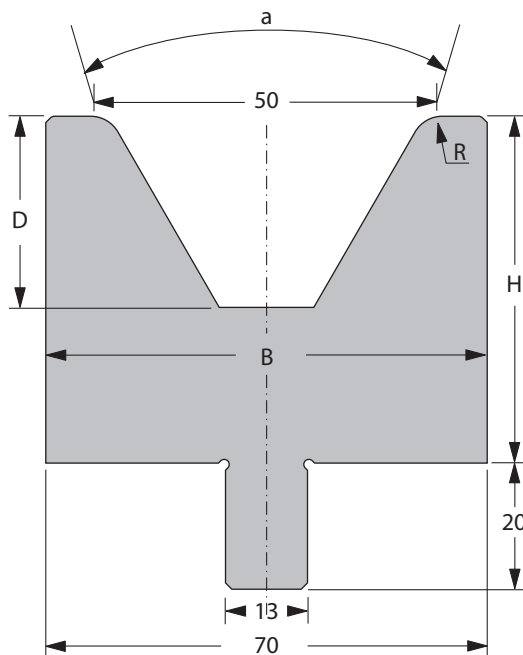
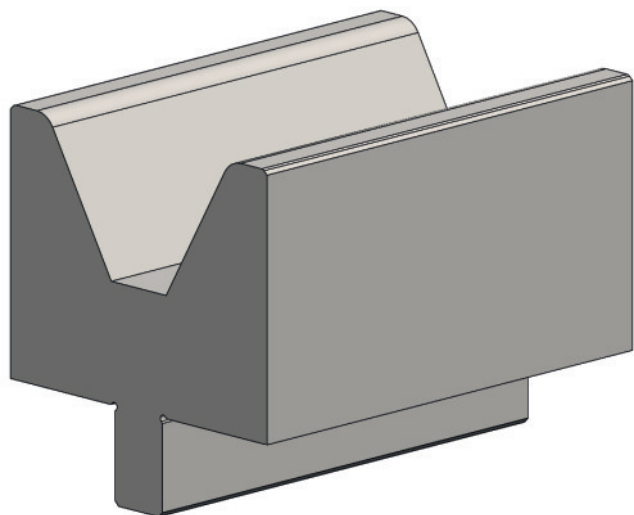

[R] Radius (mm)	5.0
[a] V - Winkel	60°
[H] Höhe (mm)	55

[B] Breite (mm)	70
[T] Tiefe (mm)	30.3
Bestell-Nr. Datenblatt OTD: 10165623	

Standardlänge	Teilenummer
10 mm	64201.0050.5027
15 mm	64201.0050.5028
20 mm	64201.0050.5029
25 mm	64201.0050.5059
30 mm	64201.0050.5030
35 mm	64201.0050.5060
40 mm	64201.0050.5061
45 mm	64201.0050.5062
50 mm	64201.0050.5063
55 mm	64201.0050.5064
60 mm	64201.0050.5065
65 mm	64201.0050.5066
70 mm	64201.0050.5067
75 mm	64201.0050.5068

Standardlänge	Teilenummer
80 mm	64201.0050.5069
85 mm	64201.0050.5070
90 mm	64201.0050.5071
95 mm	64201.0050.5072
100 mm	64201.0050.5033
200 mm	64201.0050.5016
275 mm	64201.0050.5073
300 mm	64201.0050.5040
515 mm	64201.0050.5003
550 mm FSW	64201.0050.9001
1000 mm FSC	64201.0050.0001
1030 mm	64201.0050.3003



F max 60° = 1100 kN/m
F max 90° = 1800 kN/m



24.5 kg/m



Matrizeneinsatz 13 mm



V50/60° H100

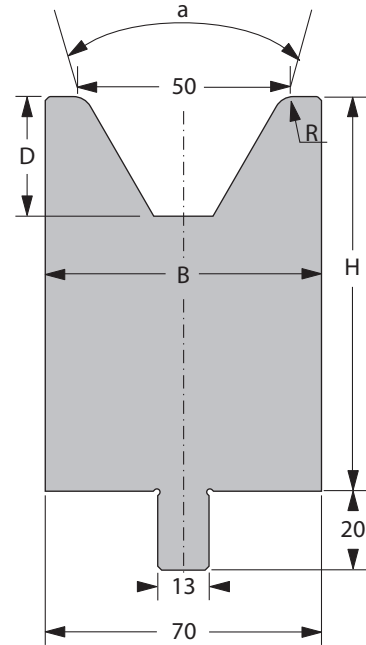
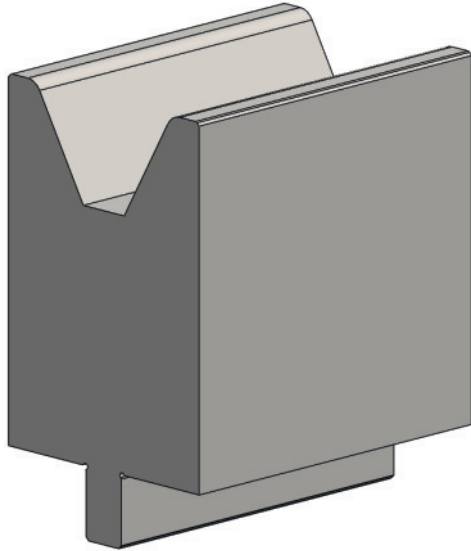

[R] Radius (mm)	5.0
[a] V - Winkel	60°
[H] Höhe (mm)	100

[B] Breite (mm)	70
[T] Tiefe (mm)	30.3

Bestell-Nr. Datenblatt OTD: 10165625

Standardlänge	Teilenummer
10 mm	64201.0050.5074
15 mm	64201.0050.5075
20 mm	64201.0050.5076
25 mm	64201.0050.5077
30 mm	64201.0050.5078
35 mm	64201.0050.5079
40 mm	64201.0050.5050
45 mm	64201.0050.5080
50 mm	64201.0050.5051
55 mm	64201.0050.5081
60 mm	64201.0050.5052
65 mm	64201.0050.5082
70 mm	64201.0050.5053
75 mm	64201.0050.5083

Standardlänge	Teilenummer
80 mm	64201.0050.5054
85 mm	64201.0050.5084
90 mm	64201.0050.5085
95 mm	64201.0050.5086
100 mm	64201.0050.5055
200 mm	64201.0050.5056
275 mm	64201.0050.5087
300 mm	64201.0050.5041
515 mm	64201.0050.5005
550 mm FSW	64201.0050.9002
1000 mm FSC	64201.0050.0004
1030 mm	64201.0050.3005



F max 60° = 1100 kN/m
F max 90° = 2000 kN/m



49.2 kg/m



Matrizeneinsatz 13 mm



V60/60° H65

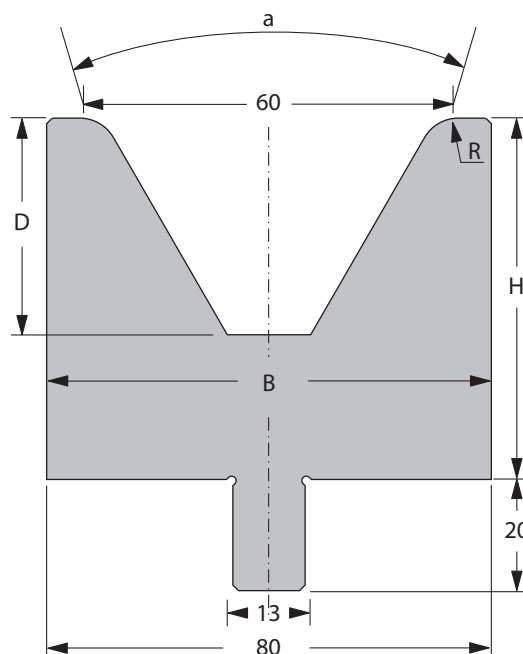
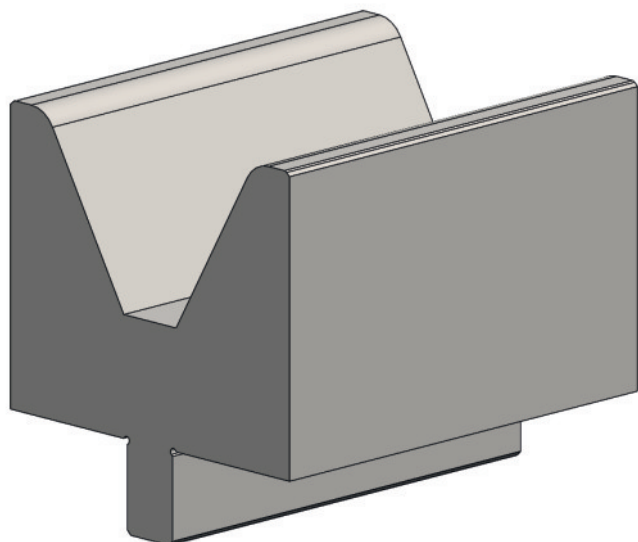

[R] Radius (mm)	7.0
[a] V - Winkel	60°
[H] Höhe (mm)	65

[B] Breite (mm)	80
[T] Tiefe (mm)	39.0

Bestell-Nr. Datenblatt OTD: 10165626

Standardlänge	Teilenummer
10 mm	64201.0060.5033
15 mm	64201.0060.5034
20 mm	64201.0060.5035
25 mm	64201.0060.5043
30 mm	64201.0060.5036
35 mm	64201.0060.5047
40 mm	64201.0060.5048
45 mm	64201.0060.5052
50 mm	64201.0060.5045
55 mm	64201.0060.5053
60 mm	64201.0060.5054
65 mm	64201.0060.5055
70 mm	64201.0060.5056
75 mm	64201.0060.5057

Standardlänge	Teilenummer
80 mm	64201.0060.5058
85 mm	64201.0060.5059
90 mm	64201.0060.5060
95 mm	64201.0060.5061
100 mm	64201.0060.5037
200 mm	64201.0060.5029
275 mm	64201.0060.5062
300 mm	64201.0060.5063
515 mm	64201.0060.5005
550 mm FSW	64201.0060.9001
1000 mm FSC	64201.0060.0002
1030 mm	64201.0060.3005



$F_{\max} 60^\circ = 1000 \text{ kN/m}$
 $F_{\max} 90^\circ = 1600 \text{ kN/m}$



31.4 kg/m



Matrizeneinsatz 13 mm



V60/60° H100

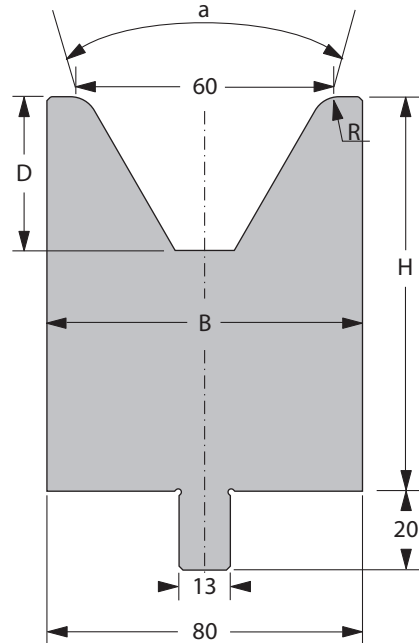
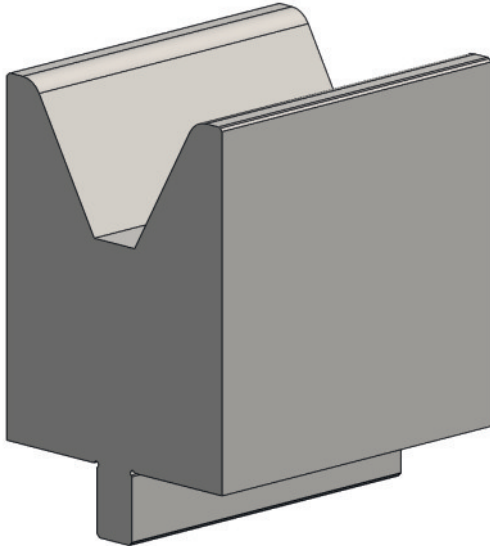

[R] Radius (mm)	7.0
[a] V - Winkel	60°
[H] Höhe (mm)	100

[B] Breite (mm)	80
[T] Tiefe (mm)	39.0
Bestell-Nr. Datenblatt OTD: 10165627	

Standardlänge	Teilenummer
10 mm	64201.0060.5064
15 mm	64201.0060.5065
20 mm	64201.0060.5066
25 mm	64201.0060.5067
30 mm	64201.0060.5068
35 mm	64201.0060.5069
40 mm	64201.0060.5070
45 mm	64201.0060.5071
50 mm	64201.0060.5072
55 mm	64201.0060.5073
60 mm	64201.0060.5074
65 mm	64201.0060.5075
70 mm	64201.0060.5077
75 mm	64201.0060.5078

Standardlänge	Teilenummer
80 mm	64201.0060.5079
85 mm	64201.0060.5080
90 mm	64201.0060.5081
95 mm	64201.0060.5082
100 mm	64201.0060.5083
200 mm	64201.0060.5040
275 mm	64201.0060.5084
300 mm	64201.0060.5021
515 mm	64201.0060.5028
550 mm FSW	64201.0060.9002
1000 mm FSC	64201.0060.0005
1030 mm	64201.0060.3011



F max 60° = 1000 kN/m
F max 90° = 1600 kN/m



53.4 kg/m



Matrizeneinsatz 13 mm



V80/80° H65

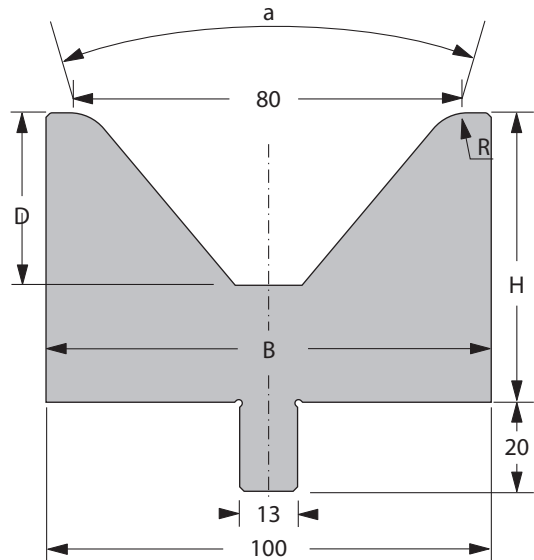
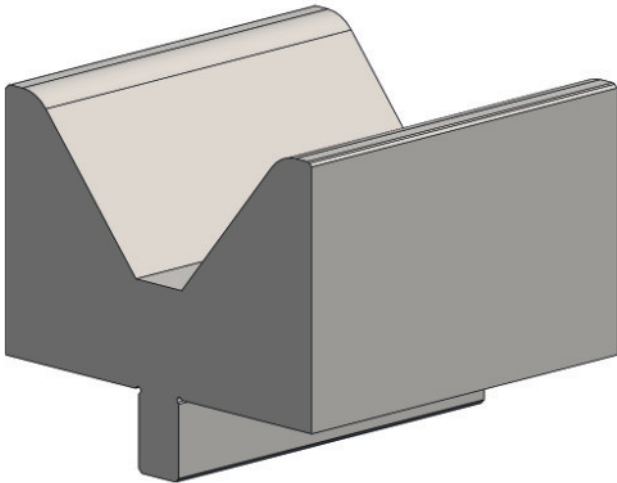

[R] Radius (mm)	10.0
[a] V - Winkel	80°
[H] Höhe (mm)	65

[B] Breite (mm)	100
[T] Tiefe (mm)	38.7

Bestell-Nr. Datenblatt OTD: 10165628

Standardlänge	Teilenummer
10 mm	64201.0080.5035
15 mm	64201.0080.5036
20 mm	64201.0080.5037
25 mm	64201.0080.5054
30 mm	64201.0080.5038
35 mm	64201.0080.5055
40 mm	64201.0080.5056
45 mm	64201.0080.5057
50 mm	64201.0080.5058
55 mm	64201.0080.5059
60 mm	64201.0080.5060
65 mm	64201.0080.5061
70 mm	64201.0080.5062
75 mm	64201.0080.5063

Standardlänge	Teilenummer
80 mm	64201.0080.5064
85 mm	64201.0080.5065
90 mm	64201.0080.5066
95 mm	64201.0080.5067
100 mm	64201.0080.5043
200 mm	64201.0080.5025
275 mm	64201.0080.5068
300 mm	64201.0080.5026
515 mm	64201.0080.5002
550 mm FSW	64201.0080.9001
1000 mm FSC	64201.0080.0001
1030 mm	64201.0080.3005



$F_{\max} 80^\circ = 1400 \text{ kN/m}$
 $F_{\max} 90^\circ = 1600 \text{ kN/m}$



38.6 kg/m



Matrizeneinsatz 13 mm



V80/80° H100

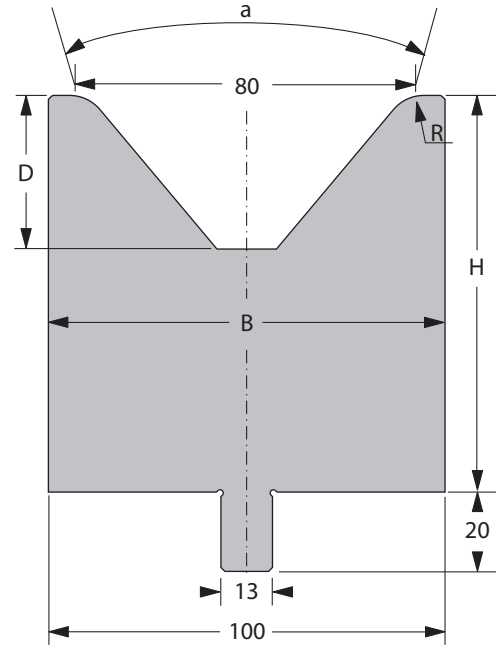
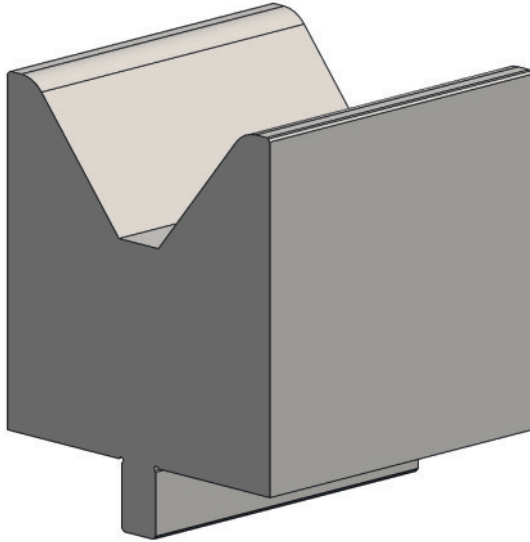

[R] Radius (mm)	10.0
[a] V - Winkel	80°
[H] Höhe (mm)	100

[B] Breite (mm)	100
[T] Tiefe (mm)	38.7

Bestell-Nr. Datenblatt OTD: 10165635

Standardlänge	Teilenummer
10 mm	64201.0080.5069
15 mm	64201.0080.5070
20 mm	64201.0080.5071
25 mm	64201.0080.5072
30 mm	64201.0080.5073
35 mm	64201.0080.5074
40 mm	64201.0080.5044
45 mm	64201.0080.5075
50 mm	64201.0080.5045
55 mm	64201.0080.5076
60 mm	64201.0080.5077
65 mm	64201.0080.5078
70 mm	64201.0080.5047
75 mm	64201.0080.5079

Standardlänge	Teilenummer
80 mm	64201.0080.5048
85 mm	64201.0080.5080
90 mm	64201.0080.5081
95 mm	64201.0080.5082
100 mm	64201.0080.5049
200 mm	64201.0080.5033
275 mm	64201.0080.5083
300 mm	64201.0080.5050
515 mm	64201.0080.5007
550 mm FSW	64201.0080.9002
1000 mm FSC	64201.0080.0004
1030 mm	64201.0080.3007



$F_{max} 90^\circ = 2800 \text{ kN/m}$



66.0 kg/m



Matrizeneinsatz 13 mm



V100/80° H85

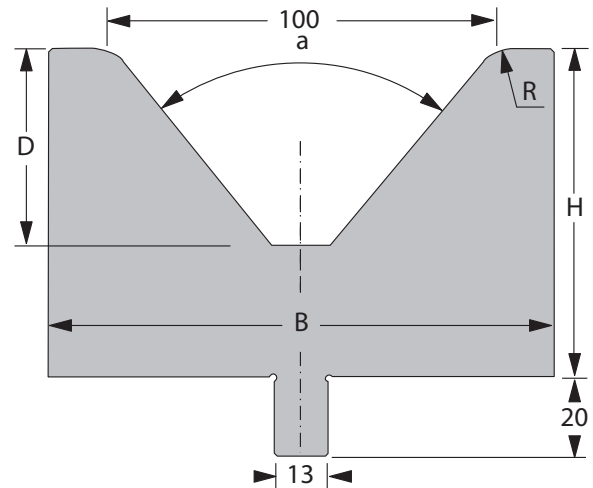
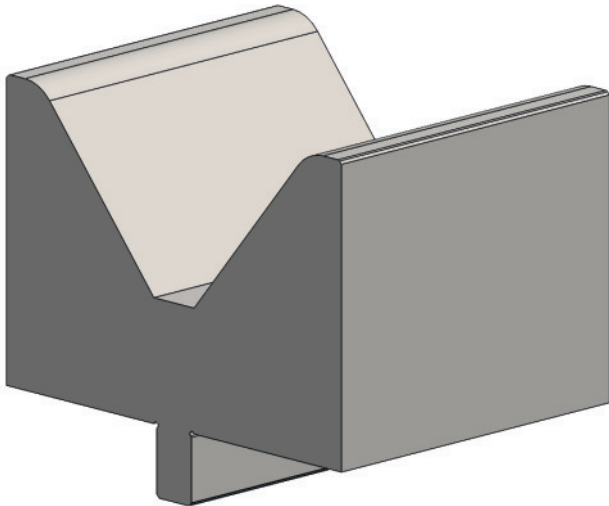

[R] Radius (mm)	12.0
[a] V - Winkel	80°
[H] Höhe (mm)	85

[B] Breite (mm)	125
[T] Tiefe (mm)	50.6

Bestell-Nr. Datenblatt OTD: 10165638

Standardlänge	Teilenummer
10 mm	64201.0100.5026
15 mm	64201.0100.5027
20 mm	64201.0100.5028
25 mm	64201.0100.5029
30 mm	64201.0100.5030
35 mm	64201.0100.5031
40 mm	64201.0100.5032
45 mm	64201.0100.5033
50 mm	64201.0100.5034
55 mm	64201.0100.5035
60 mm	64201.0100.5036
65 mm	64201.0100.5037
70 mm	64201.0100.5038
75 mm	64201.0100.5039

Standardlänge	Teilenummer
80 mm	64201.0100.5040
85 mm	64201.0100.5041
90 mm	64201.0100.5042
95 mm	64201.0100.5043
100 mm	64201.0100.5044
200 mm	64201.0100.5018
275 mm	64201.0100.5045
300 mm	64201.0100.5015
515 mm	64201.0100.5004
550 mm FSW	64201.0100.9001
1000 mm FSC	64201.0100.0001
1030 mm	64201.0100.3005



$F_{\max} 80^\circ = 1750 \text{ kN/m}$
 $F_{\max} 90^\circ = 2000 \text{ kN/m}$



62.5 kg/m



Matrizeneinsatz 13 mm



V120/80° H105

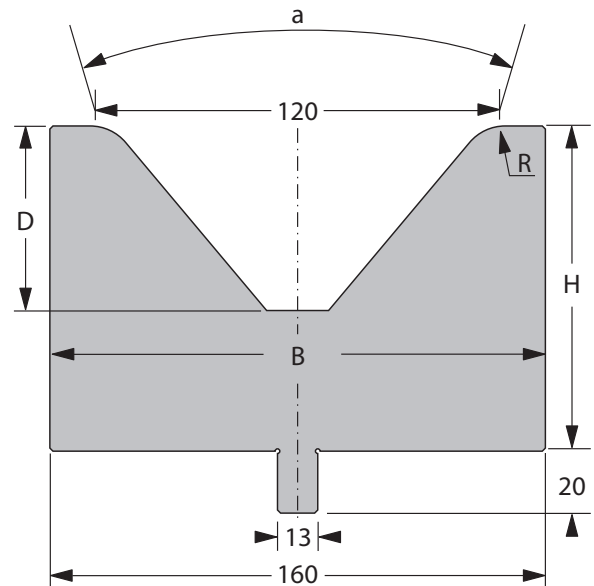
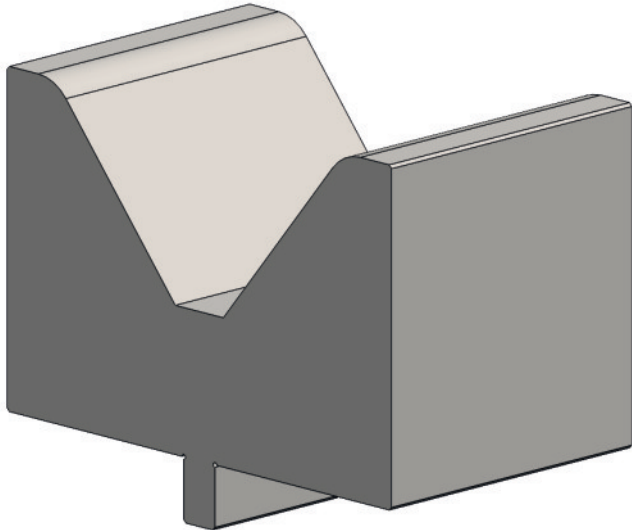

[R] Radius (mm)	15.0
[a] V - Winkel	80°
[H] Höhe (mm)	105

[B] Breite (mm)	160
[T] Tiefe (mm)	60.0

Bestell-Nr. Datenblatt OTD: 10165639

Standardlänge	Teilenummer
10 mm	64201.0120.5027
15 mm	64201.0120.5028
20 mm	64201.0120.5029
25 mm	64201.0120.5030
30 mm	64201.0120.5031
35 mm	64201.0120.5032
40 mm	64201.0120.5033
45 mm	64201.0120.5034
50 mm	64201.0120.5035
55 mm	64201.0120.5036
60 mm	64201.0120.5037
65 mm	64201.0120.5038
70 mm	64201.0120.5039
75 mm	64201.0120.5040

Standardlänge	Teilenummer
80 mm	64201.0120.5041
85 mm	64201.0120.5042
90 mm	64201.0120.5043
95 mm	64201.0120.5044
100 mm	64201.0120.5025
200 mm	64201.0120.5011
275 mm	64201.0120.5019
300 mm	64201.0120.5045
515 mm	64201.0120.5002
550 mm FSW	64201.0120.9001
1000 mm FSC	64201.0120.0001
1030 mm	64201.0120.3004



F max 80° = 2200 kN/m
F max 90° = 2400 kN/m



101.0 kg/m



Matrizeneinsatz 13 mm



S1 H45

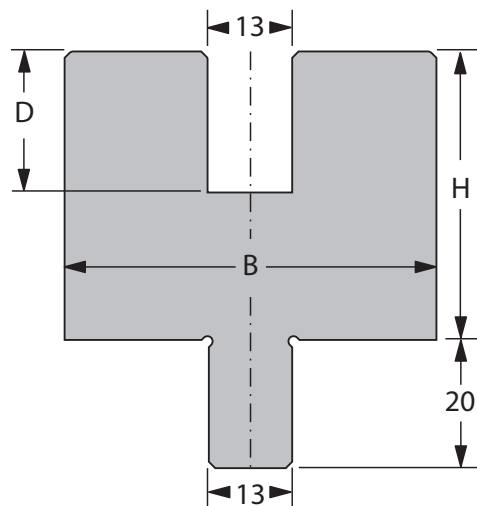
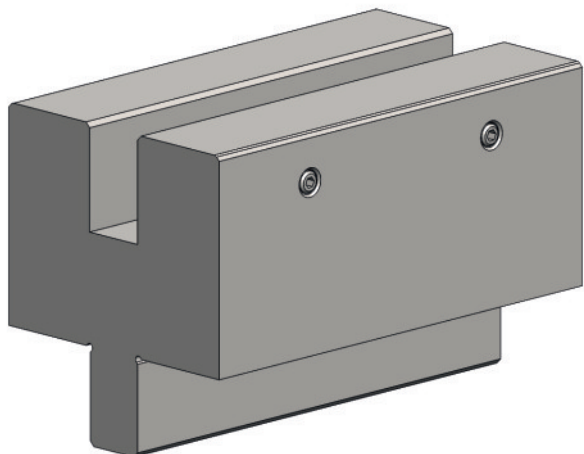

[R] Radius (mm)	-
[a] V - Winkel	-
[B] Breite (mm)	58

[T] Tiefe (mm)	22
----------------	----

Bestell-Nr. Datenblatt OTD: 10166736



F max = 2000 kN/m



20.0 kg/m



Matrizeneinsatz 13 mm

S1 H73

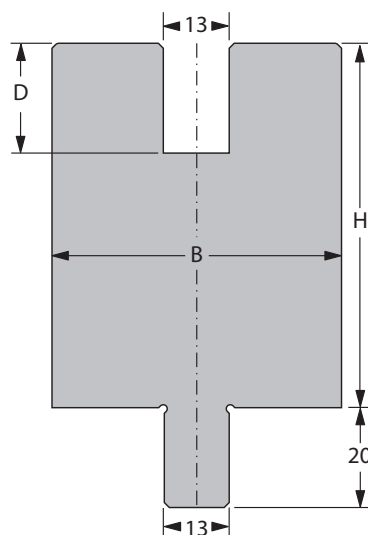
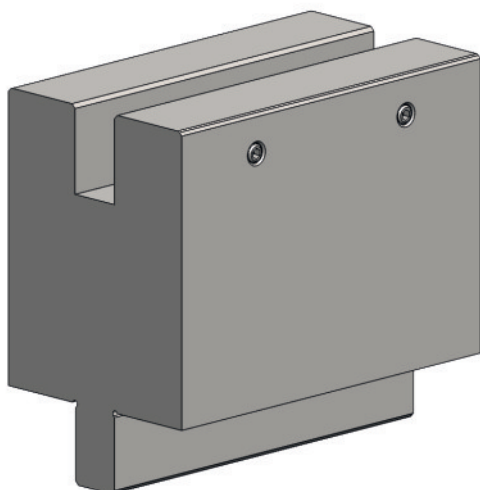

[R] Radius (mm)	-
[a] V - Winkel	-
[B] Breite (mm)	58

[T] Tiefe (mm)	22
----------------	----

Bestell-Nr. Datenblatt OTD: 10166738



F max = 2000 kN/m



33.0 kg/m



Matrizeneinsatz 13 mm



S1 H100

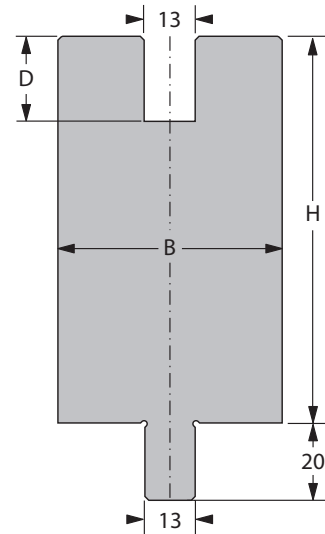
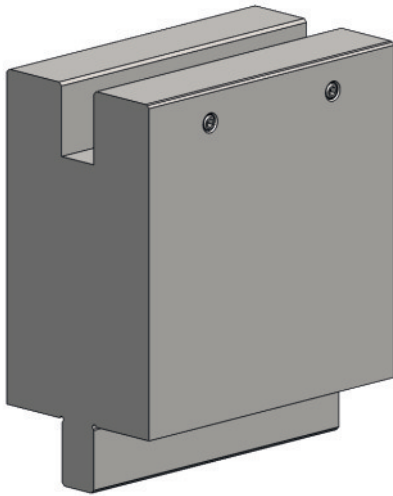

[R] Radius (mm)	-
[a] V - Winkel	-
[B] Breite (mm)	58

[T] Tiefe (mm)	22
Bestell-Nr. Datenblatt OTD: 10166739	



$F_{max} = 5000 \text{ kN/m}$



45.3 kg/m



Matrizeneinsatz 13 mm

Höhe	Standardlänge	Teilenummer
45 mm	515 mm	64201.0001.5010
	550 mm FSW	64201.0001.9004
	1000 mm FSC	64201.0001.0005
	1030 mm	64201.0001.3006
73 mm	515 mm	64201.0001.5008
	550 mm FSW	64201.0001.9001
	1000 mm FSC	64201.0001.0003
	1030 mm	64201.0001.3003
100 mm	515 mm	64201.0001.5006
	550 mm FSW	64201.0001.9002
	1000 mm FSC	64201.0001.0001
	1030 mm	64201.0001.3004



Zudrückwerkzeuge

Flachdrückwerkzeuge







P11 H175 B20

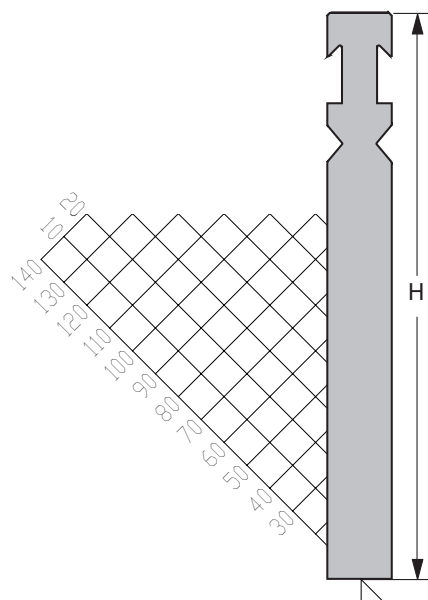
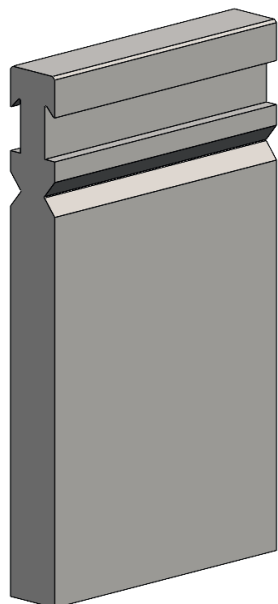

[R] Radius (mm)	-
[a] V - Winkel	-
[H] Höhe (mm)	175

Bestell-Nr. Datenblatt OTD: 10165774

Standardlänge	Teilenummer
515 mm	65206.0011.5004
1030 mm	65206.0011.3001
1000 mm FSC	65206.0011.0002



F max = 2000 kN/m



26.7 kg/m



P11 H250 B20

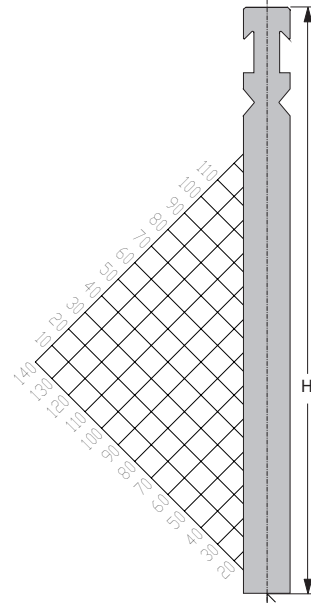
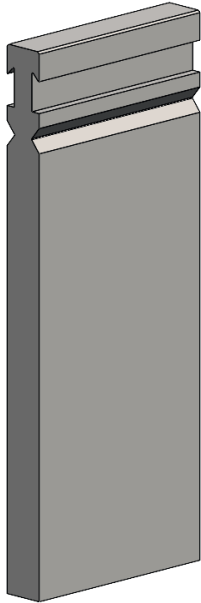

[R] Radius (mm)	-
[a] V - Winkel	-
[H] Höhe (mm)	250

Bestell-Nr. Datenblatt OTD: 10165775

Standardlänge	Teilenummer
515 mm	65206.0011.5003
1030 mm	65206.0011.3002
1000 mm FSC	65206.0011.0001



F max = 2000 kN/m



38.5 kg/m



P11 H175 B40

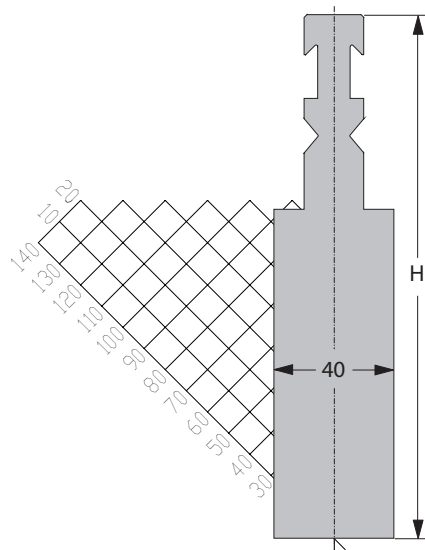
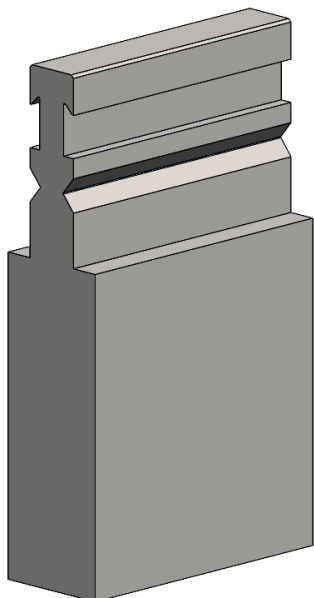

[R] Radius (mm)	-
[a] V - Winkel	-
[H] Höhe (mm)	175

Bestell-Nr. Datenblatt OTD: 10165776

Standardlänge	Teilenummer
515 mm	65206.0011.5032
1030 mm	65206.0011.3003
1000 mm FSC	65206.0011.0006



F max = 1600 kN/m



43.9 kg/m



P11 H250 B40

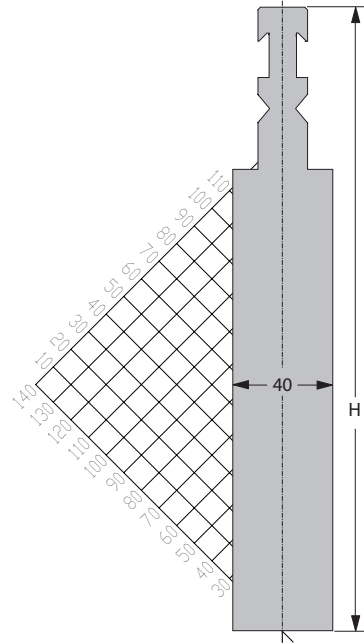
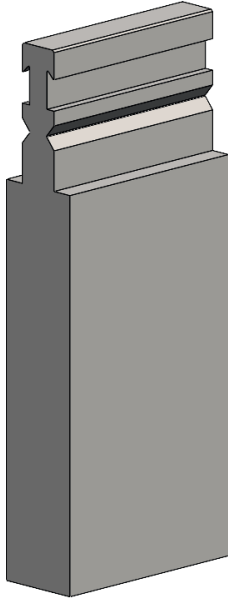

[R] Radius (mm)	-
[a] V - Winkel	-
[H] Höhe (mm)	250

Bestell-Nr. Datenblatt OTD: 10165777

Standardlänge	Teilenummer
515 mm	65206.0011.5033
1030 mm	65206.0011.3004
1000 mm FSC	65206.0011.0007



F max = 1600 kN/m



67.4 kg/m



V-Flach H55

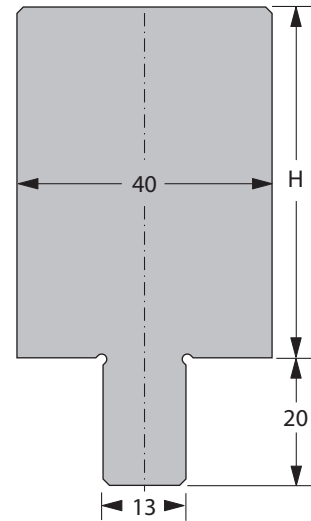
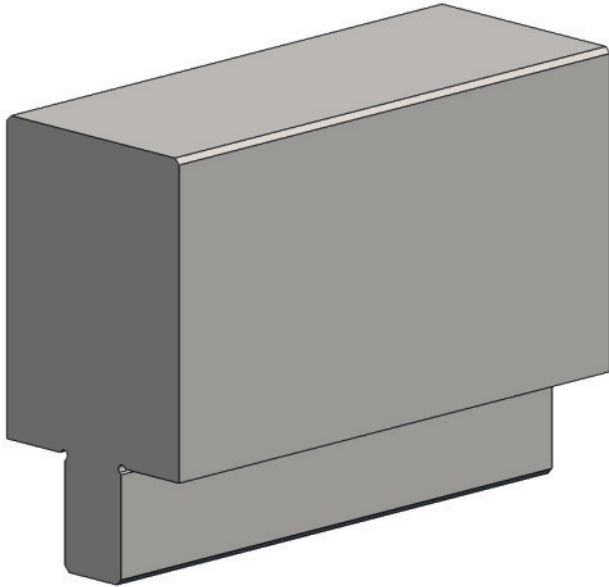

[R] Radius (mm)	-
[a] V - Winkel	-
[H] Höhe (mm)	55

Bestell-Nr. Datenblatt OTD: 10166101

Standardlänge	Teilenummer
515 mm	64201.0000.5002
1030 mm	64201.0000.3002
1000 mm FSC	64201.0000.0010



$F_{max} = 2000 \text{ kN/m}$



19.3 kg/m



V-Flach H100

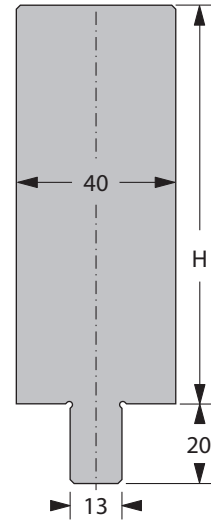
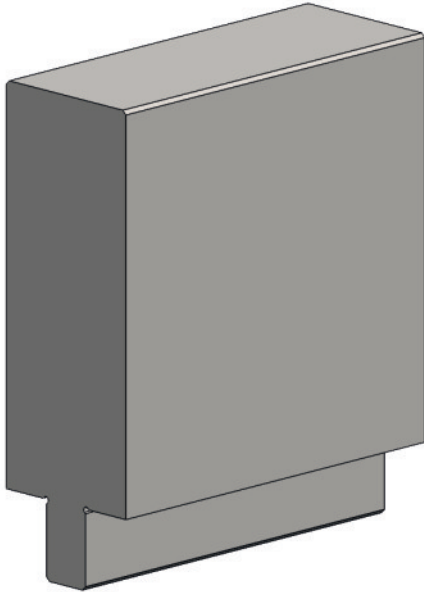

[R] Radius (mm)	-
[a] V - Winkel	-
[H] Höhe (mm)	100

Bestell-Nr. Datenblatt OTD: 10166102

Standardlänge	Teilenummer
515 mm	64201.0000.5003
1030 mm	64201.0000.3007
1000 mm FSC	64201.0000.0011



F max = 2000 kN/m



33.5 kg/m



P900/06 RF-A H175

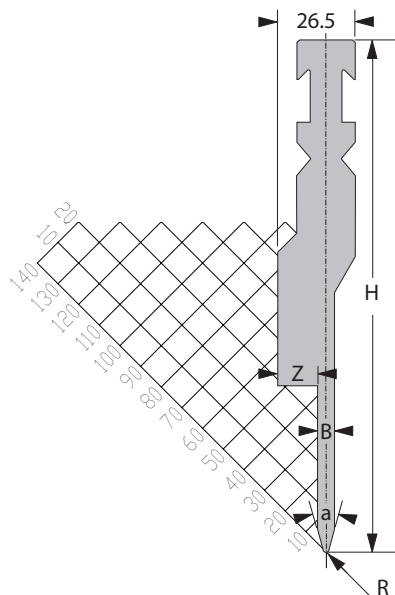
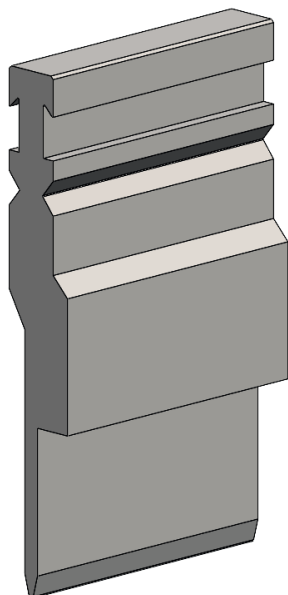

[R] Radius (mm)	1.0
[a] V - Winkel	30°
[H] Höhe (mm)	175

[B] Breite (mm)	5.8
[Z] Breite (mm)	13.6
Bestell-Nr. Datenblatt OTD: 10165778	

Standardlänge	Teilenummer
515 mm	65206.0900.5013
1030 mm	65206.0900.3004
1000 mm FSC	65206.0900.0010



F max = 1000 kN/m



19.6 kg/m



Matrizeneinsatz 13 mm



P900/06 RF-A H250

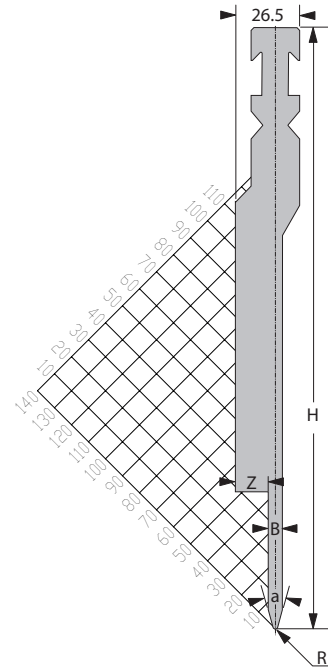
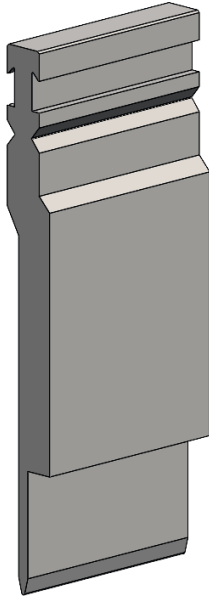

[R] Radius (mm)	1.0
[a] V - Winkel	30°
[H] Höhe (mm)	250

[B] Breite (mm)	5.8
[Z] Breite (mm)	13.6

Bestell-Nr. Datenblatt OTD: 10165783

Standardlänge	Teilenummer
515 mm	65206.0900.5029
1030 mm	65206.0900.3007
1000 mm FSC	65206.0900.0019



F max = 1000 kN/m



31.0 kg/m



Matrizeneinsatz 13 mm



P900/08 RF-A H175

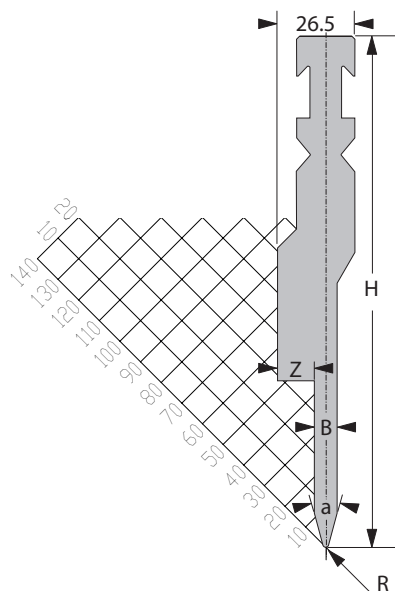
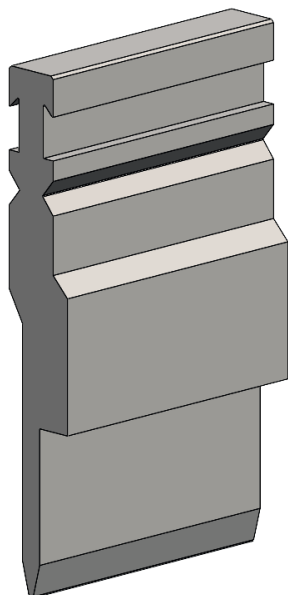

[R] Radius (mm)	1.0
[a] V - Winkel	30°
[H] Höhe (mm)	175

[B] Breite (mm)	7.8
[Z] Breite (mm)	12.6
Bestell-Nr. Datenblatt OTD: 10165785	

Standardlänge	Teilenummer
515 mm	65206.0900.5005
1030 mm	65206.0900.3002
1000 mm FSC	65206.0900.0002



F max = 1000 kN/m



21.2 kg/m



Matrizeneinsatz 13 mm



P900/08 RF-A H250

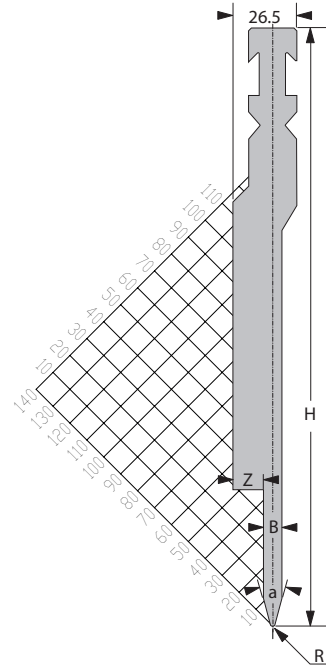
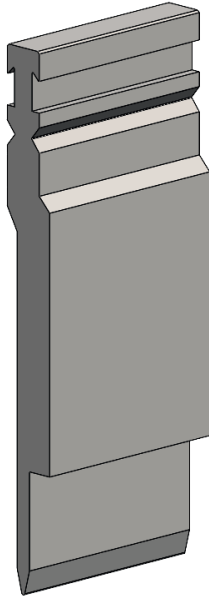

[R] Radius (mm)	1.0
[a] V - Winkel	30°
[H] Höhe (mm)	250

[B] Breite (mm)	7.8
[Z] Breite (mm)	12.6

Bestell-Nr. Datenblatt OTD: 10165793

Standardlänge	Teilenummer
515 mm	65206.0900.5027
1030 mm	65206.0900.3008
1000 mm FSC	65206.0900.0016



F max = 1000 kN/m



29.2 kg/m



Matrizeneinsatz 13 mm



P900/10 RF-A H175

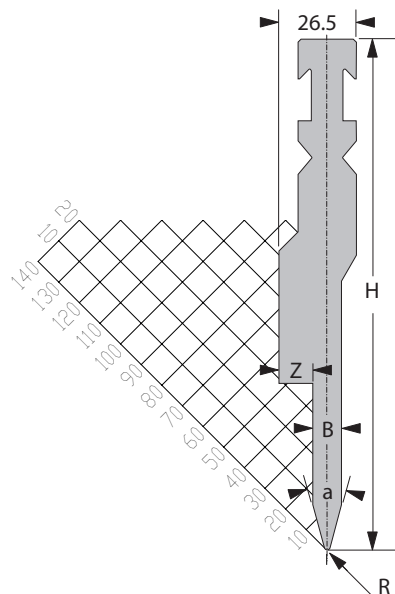
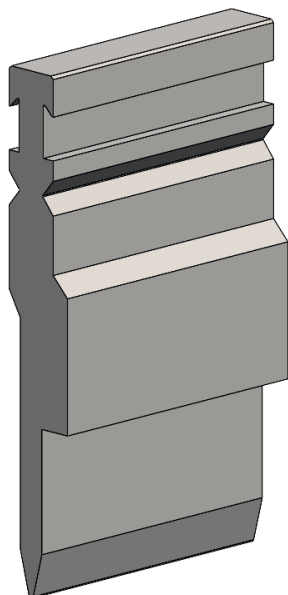

[R] Radius (mm)	1.0
[a] V - Winkel	30°
[H] Höhe (mm)	175

[B] Breite (mm)	9.8
[Z] Breite (mm)	11.6
Bestell-Nr. Datenblatt OTD: 10165796	

Standardlänge	Teilenummer
515 mm	65206.0900.5004
1030 mm	65206.0900.3005
1000 mm FSC	65206.0900.0004



F max = 1000 kN/m



21.7 kg/m



Matrizeneinsatz 13 mm



P900/10 RF-A H250

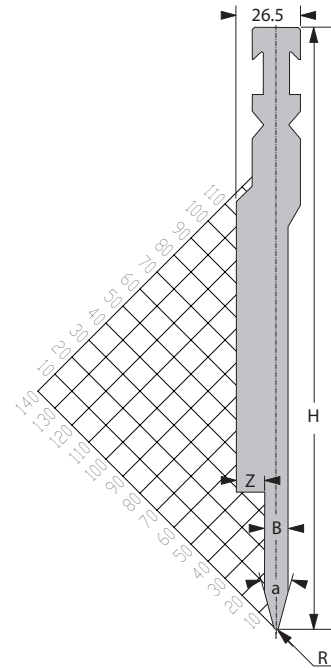
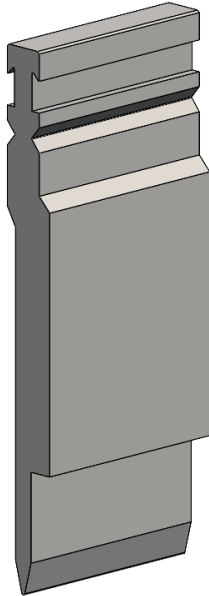

[R] Radius (mm)	1.0
[a] V - Winkel	30°
[H] Höhe (mm)	250

[B] Breite (mm)	9.8
[Z] Breite (mm)	11.6
Bestell-Nr. Datenblatt OTD: 10165798	

Standardlänge	Teilenummer
515 mm	65206.0900.5008
1030 mm	65206.0900.3009
1000 mm FSC	65206.0900.0006



F max = 1000 kN/m



34.3 kg/m



Matrizeneinsatz 13 mm



P900/12 RF-A H175

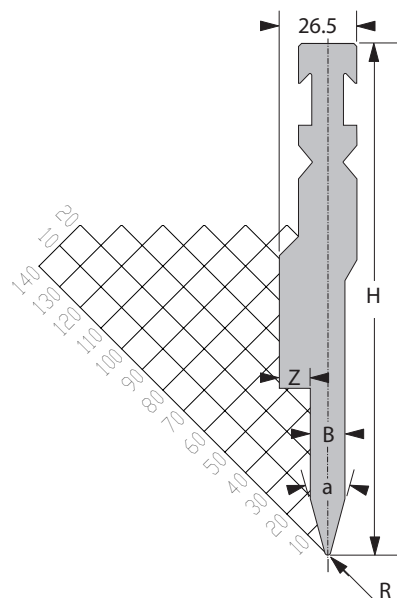
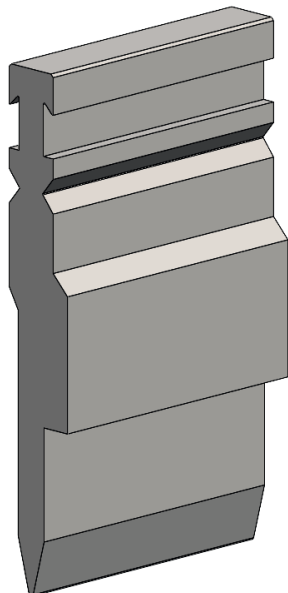

[R] Radius (mm)	1.0
[a] V - Winkel	30°
[H] Höhe (mm)	175

[B] Breite (mm)	11.8
[Z] Breite (mm)	10.6

Bestell-Nr. Datenblatt OTD: 10165804

Standardlänge	Teilenummer
515 mm	65206.0900.5007
1030 mm	65206.0900.3003
1000 mm FSC	65206.0900.0003



F max = 1000 kN/m



22.6 kg/m



Matrizeneinsatz 13 mm



P900/12 RF-A H250

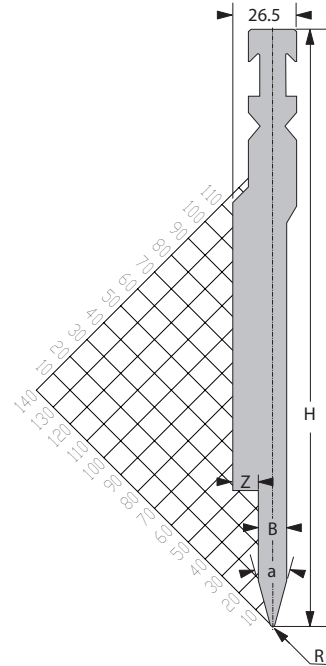
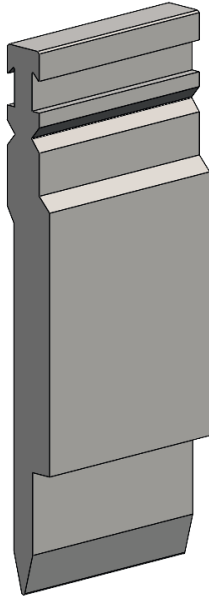

[R] Radius (mm)	1.0
[a] V - Winkel	30°
[H] Höhe (mm)	250

[B] Breite (mm)	11.8
[Z] Breite (mm)	10.6

Bestell-Nr. Datenblatt OTD: 10165806

Standardlänge	Teilenummer
515 mm	65206.0900.5015
1030 mm	65206.0900.3010
1000 mm FSC	65206.0900.0018



F max = 1000 kN/m



35.7 kg/m



Matrizeneinsatz 13 mm



V900/06 H85

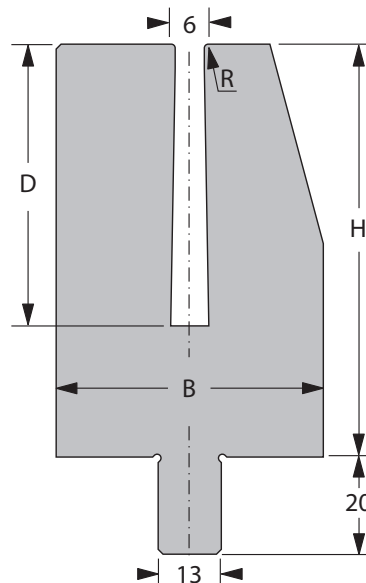
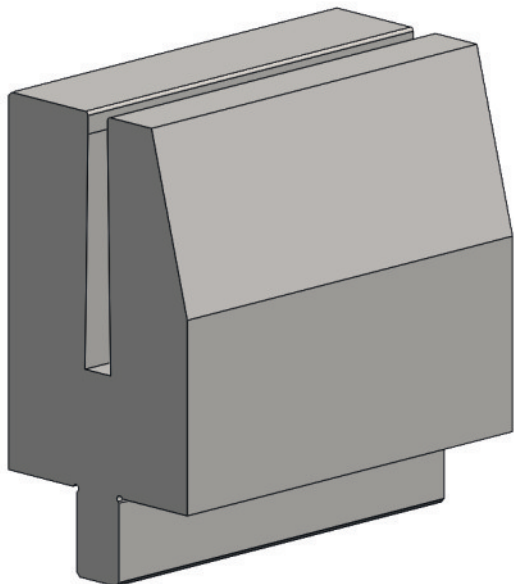

[R] Radius (mm)	0.8
[a] V - Winkel	-
[H] Höhe (mm)	85

[B] Breite (mm)	55
[T] Tiefe (mm)	58

Bestell-Nr. Datenblatt OTD: 10166107

Standardlänge	Teilenummer
515 mm	64201.0900.5010
1030 mm	64201.0900.3007
1000 mm FSC	64201.0900.0006



F max = 250 kN/m



34.5 kg/m



Matrizeneinsatz 13 mm



V900/08 H85

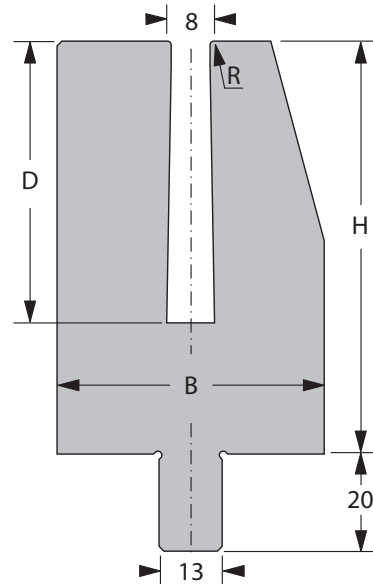
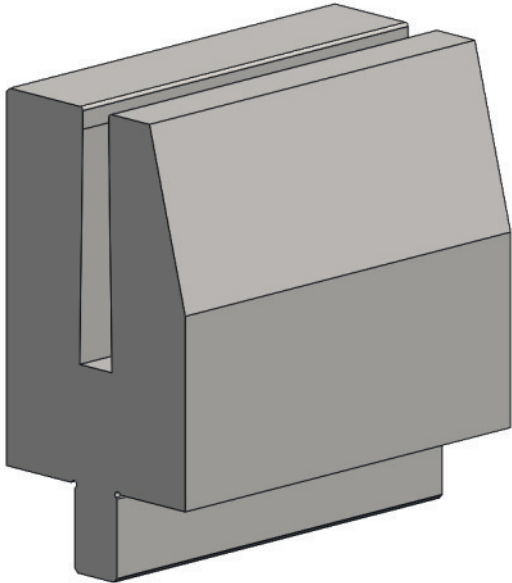

[R] Radius (mm)	0.8
[a] V - Winkel	-
[H] Höhe (mm)	85

[B] Breite (mm)	55
[T] Tiefe (mm)	58

Bestell-Nr. Datenblatt OTD: 10166109

Standardlänge	Teilenummer
515 mm	64201.0900.5005
1030 mm	64201.0900.3003
1000 mm FSC	64201.0900.0002



F max = 250 kN/m



33.5 kg/m



Matrizeneinsatz 13 mm



V900/10 H85

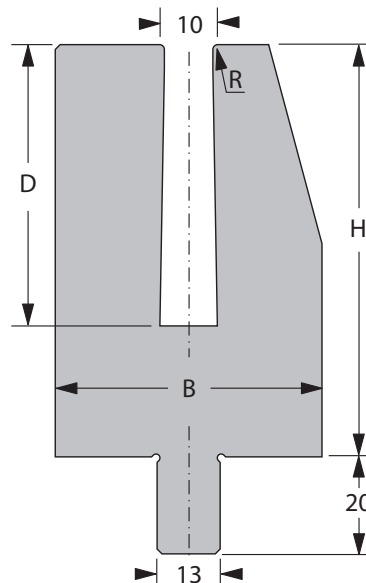
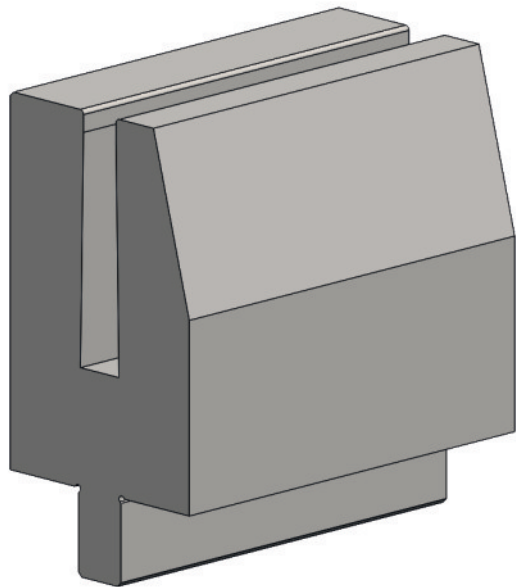

[R] Radius (mm)	1.0
[a] V - Winkel	-
[H] Höhe (mm)	85

[B] Breite (mm)	55
[T] Tiefe (mm)	58

Bestell-Nr. Datenblatt OTD: 10166110

Standardlänge	Teilenummer
515 mm	64201.0900.5004
1030 mm	64201.0900.3004
1000 mm FSC	64201.0900.0004



F max = 250 kN/m



32.0 kg/m



Matrizeneinsatz 13 mm



V900/12 H85

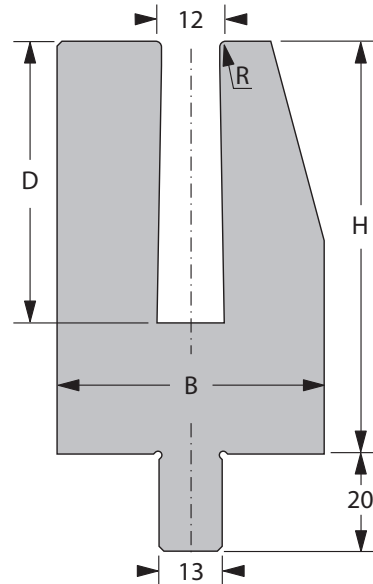
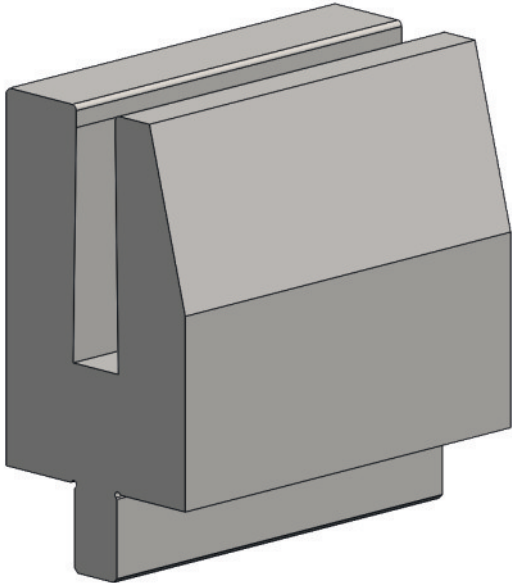

[R] Radius (mm)	1.2
[a] V - Winkel	-
[H] Höhe (mm)	85

[B] Breite (mm)	55
[T] Tiefe (mm)	58

Bestell-Nr. Datenblatt OTD: 10166111

Standardlänge	Teilenummer
515 mm	64201.0900.5007
1030 mm	64201.0900.3006
1000 mm FSC	64201.0900.0003



F max = 250 kN/m



31.0 kg/m



Matrizeneinsatz 13 mm



Sonderbiegewerkzeuge

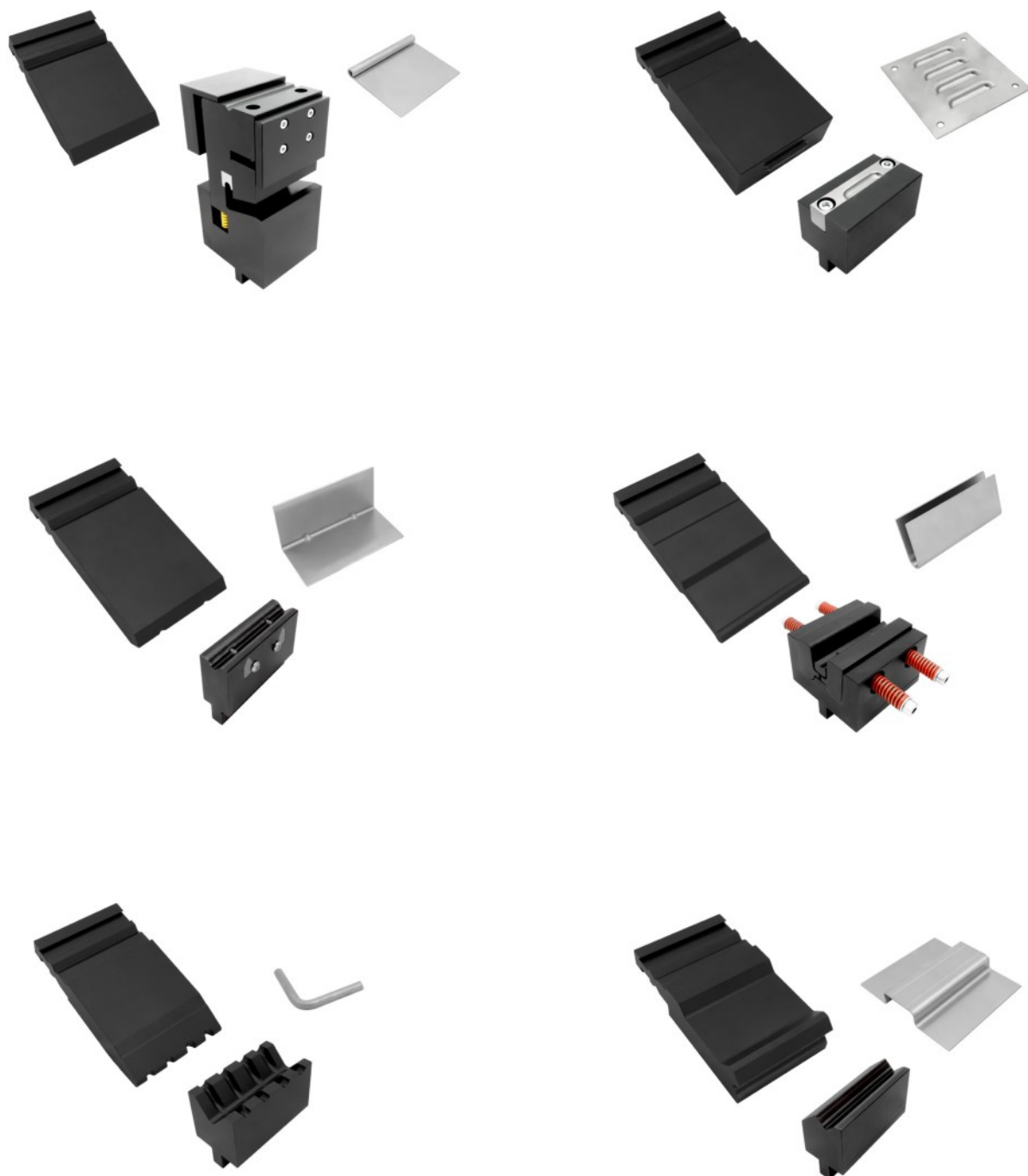

Auch Sonderwerkzeuge gehören zum Werkzeugprogramm von Bystronic.

Bei Interesse wenden Sie sich bitte an Ihren örtlichen Händler oder unsere örtliche Tochtergesellschaft.



Hochleistungswerkzeuge

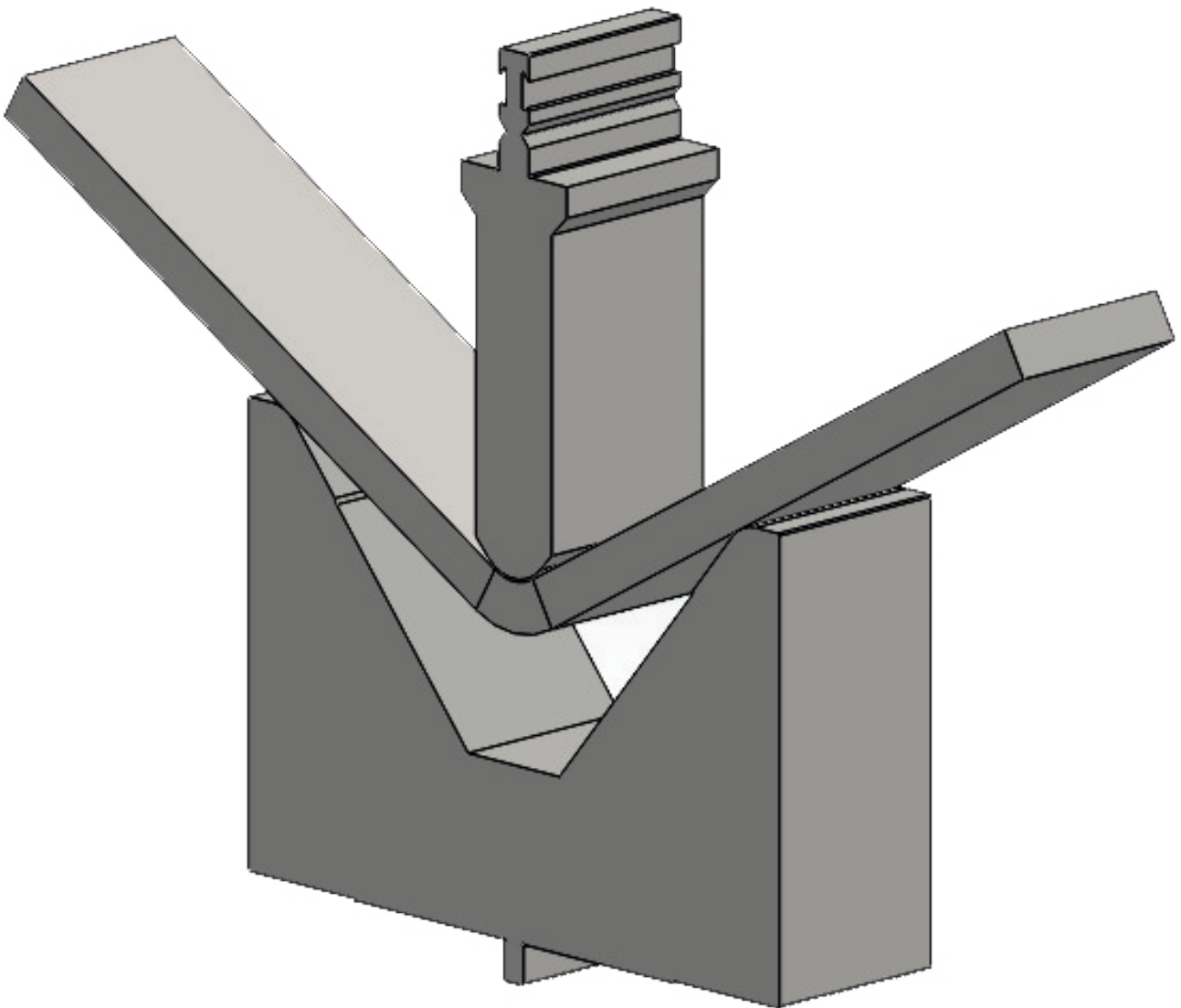

Auch Hochleistungswerkzeuge gehören zum Werkzeugprogramm von Bystronic.
Bei Interesse wenden Sie sich bitte an Ihren örtlichen Händler oder die örtliche Tochtergesellschaft.



Kontakte weltweit

Bystronic Laser AG
Industriestrasse 21
3362 Niederönz
Schweiz
Tel. +41 62 956 33 33
E-Mail: info.laser@bystronic.com

Bystronic Australia Pty. Ltd.
4 Latchford Street
Cranbourne West VIC 3977
Australien
Tel.: +61 1300 975 761
E-Mail: info.au@bystronic.com

Bystronic Austria GmbH
Schärdinger Strasse 15
4061 Pasching
Österreich
Tel. +43 7229 64411
E-Mail: office.at@bystronic.com

Bystronic do Brasil Ltda.
Rua Parma 203
83413-587 – Colombo – PR
Brasilien
Tel. +55 41 3666 9000
E-Mail: bystronic.br@bystronic.com

Bystronic Canada Ltd
3330 Ridgeway Drive, Unit #11
Mississauga, ON L5L 5Z9
Kanada
Tel.: +1 905 890 2999
E-Mail: sales.canada@bystronic.com

Bystronic (Tianjin) Laser Ltd.
No. 46 Xishi Road
Airport Industrial Park
300308 Tianjin
China
Tel.: +86 22 5980 1888
E-Mail: info.tj.cn@bystronic.com

Bystronic Czech Republic s.r.o.
Turanka 115/1222
627 00 Brno Slatina
Tschechische Republik
Tel. +420 532 123 314
E-Mail: info.cz@bystronic.com

Bystronic Ibérica, S.A.
Avda. Tenerife n° 2
Edificio 1, Planta 3, Oficina D
28700 San Sebastián de los Reyes
(Madrid) Spanien
Tel. +34 91 654 48 78
E-Mail: sales.es@bystronic.com

Bystronic France SAS
Parc Technopolis
3, Avenue du Canada
91940 Les Ulis Cedex
Frankreich
Tel. +33 1 69 41 99 84
E-Mail: info.fr@bystronic.com

Bystronic Maschinenbau GmbH
Mühlhäuser Strasse 3
99867 Gotha
Deutschland
Tel. +49 3621 38 30
E-Mail: info.bending@bystronic.com

Bystronic Deutschland GmbH
Römerstrasse 14
71296 Heimsheim
Deutschland
Tel. +49 7033 46 99 0
E-Mail: info.de@bystronic.com

Bystronic Magyarország Kft.
Budaörs Business Center
Puskás Tivadarút 5
2040 Budaörs
Ungarn
Tel.: +36 23 610 433
E-Mail: info.hu@bystronic.com

Bystronic Laser India (Pvt) Ltd.
7C, Tadiwala Road
Neben Hotel Pancharatna
Pune 411 001
Indien
Tel.: +91 20 67294800
E-Mail: info.in@bystronic.com

Bystronic Italia SRL
Via del Lavoro, 30
20813 Bovisio-Masciago
Italien
Tel. +39 0362 5993 1
E-Mail: sales.it@bystronic.com

Bystronic Japan, Ltd.
2-95-3 Inadaira Musashimurayama-shi
Tokio 208-0023
Japan
Tel.: +81 42 506 8271
E-Mail: Cesar.Mujica@bystronic.com





Bystronic Laser Pte. Ltd.

(Vertretungsbüro)
Level 8, MCT Tower, Sky Park,
One City, Jalan USJ 25/1
Subang Jaya
47650 Selangor
Malaysia
Tel.: +60 3 8022 8268

Bystronic Mexico S.A. de C.V.

Helios 401 A, Parque Industrial FINSA
Apodaca
66600 Nuevo León
Mexiko
Tel. +52 81 2133 7600
E-Mail: sales.mexico@bystronic.com

Bystronic Benelux B.V.

Duurzaamheidsring 11
4231 EX Meerkerk
Niederlande
Tel. +31 184 611 020
E-Mail: sales.benelux@bystronic.com

Bystronic Korea, Ltd.

3F Bystronic Building,
32-18, LS-ro
91 Beon-gil, Dongan-gu Anyang-si
14119 Gyeonggi-do
Korea
Tel. +82 31 389 9800
E-Mail: info.kr@bystronic.com

Bystronic Polska Sp. z o.o.

Ul. Sokolowska 47
PL-05-806 Sokolów
Polen
Tel. +48 22 331 37 70
E-Mail: info.pl@bystronic.com

S.C. Bystronic Laser S.R.L.

Str. Poienelor no. 5
Industrial Pro Roman Park
500419 Brasov
Rumänien
Tel.: +40 268 322 140
E-Mail: info.ro@bystronic.com

Bystronic Laser

Zorge Street, 9A
Stroenie 2 (Building 2)
125252 Moskau
Russland
Tel.: +7 495 984 71 44
E-Mail: info.ru@bystronic.com

Bystronic Co., Ltd. (Shanghai)

Room 602, Part A,
No. 388 North Fu Quan Road
Changning District
Shanghai, 200335
Tel. +86 21 6082 9300
E-Mail: info.sha.cn@bystronic.com

Bystronic Pte. Ltd.

Thye Hong Centre
2 Leng Kee Road #02-04
159086 Singapur
Tel. +65 6472 6300
E-Mail: info.sg@bystronic.com

Bystronic Scandinavia AB

Metallvägen 30A
195 72 Rosersberg
Schweden
Tel.: +46 (0)8 594 415 50
E-Mail: Services.SE@bystronic.com

Bystronic Sales AG

Industriestrasse 21
3362 Niederörsz
Schweiz
Tel. +41 62 956 37 83
E-Mail: info.sales@bystronic.com

Bystronic International Laser Ltd.

No. 66, Wuquan Rd.,
Wugu District,
New Taipei City 248
Taiwan (R.O.C)
Tel.: +886 2 2299 2699
E-Mail: hotline.tw@bystronic.com

Bystronic Lazer ve Su Isinlari

Makineleri Sanayi ve Ticaret Ltd. Sti.
Serifali Mevkii, Barbaros Caddesi
No.: 66 K:1
34775 Ümraniye/Istanbul
Türkei
Tel.: +90 216 464 6160
E-Mail: info.tr@bystronic.com

LLC Bystronic Ukraine

59 Zhylyanskaya Street
Diplomat Hall, 2nd floor, Office 207
1033 Kyiv
Ukraine
Tel. +380 44 569 74 37
E-Mail: info.cis@bystronic.com

Bystronic UK Ltd.

6 Wayside Business Park
Wilson's Lane
Coventry
Warwickshire CV6 6NY
Vereinigtes Königreich
Tel.: +44 (0)844 848 5850
E-Mail: sales.uk@bystronic.com

Bystronic Inc.

2200 West Central Road
US-Hoffman Estates
IL 60192
USA
Tel. +1 847 214 0300
E-Mail: sales.us@bystronic.com

Bystronic Vietnam Co. Ltd.

38/7 Truong Chinh Str.
Tan Thoi Nhat Ward
District 12
Hochiminh City
Vietnam
Tel.: +84 28 3719 2278
E-Mail: Anhtuan.Ha@bystronic.com

