

Best choice.

Cięcie. Gięcie. Automatykacja.

Bystronic

Narzędzia Bystronic

Nasze narzędzia RF-AC

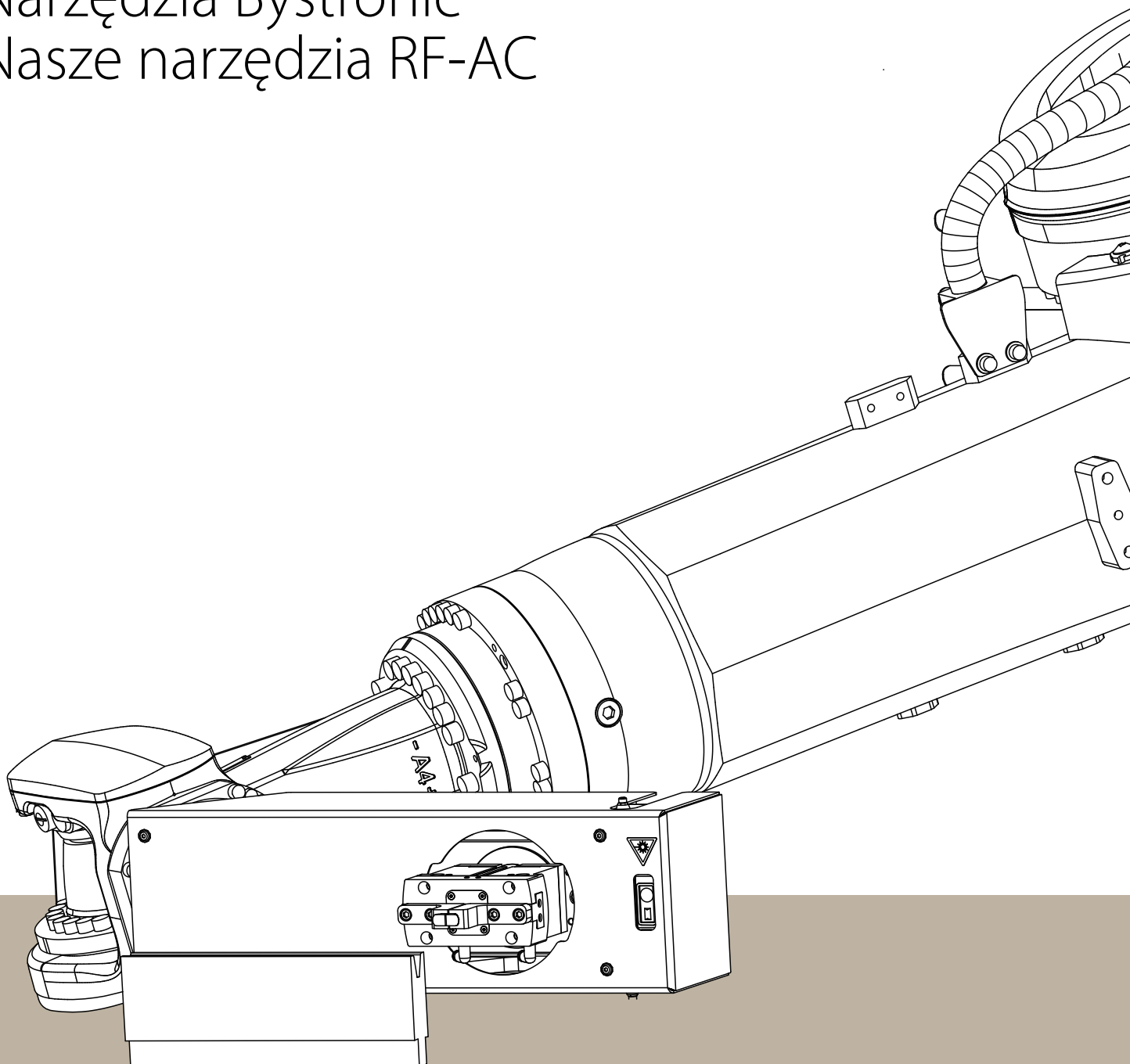



Spis treści

Informacje podstawowe	3
Ikony używane w tym katalogu.....	3
Podstawy obliczania gięcia powietrznego....	4
Jak przebiega wymiana narzędzi?	8
Wycięcia.....	9
Segmentacje.....	10
Narzędzia górne	14
Segmenty narzędzi górnych.....	16
Matryce	22
Opcje stołu dolnego	24
Segmentacja matrycy	25
Narzędzia do zaginania	60
Dane kontaktowe na świecie.....	70



Informacje podstawowe

Ikony używane w tym katalogu



twardość: 58 - 62 HRC



maks. dopuszczalne obciążenie



maks. głębokość skrzynki



masa



narzędzie odwracalne

Ten katalog dotyczy następujących maszyn:

Xpert Tool Changer - XTC

Modular Tool Changer - MTC

Bending Cell - BC



Podstawy obliczania gięcia powietrznego

Tabela wydajności gięcia powietrznego

Zamieszczone dane zostały obliczone na podstawie gięcia materiału o sile rozciągania $R_m = 420 \text{ N/mm}^2$ na długości 1 m.

V	6	8	10	12	16	18	20	24	32	40	50	60	80
R	1	1,2	1,6	2	2,5	2,8	3	3,5	5	6	8	9,5	12
t	F	Siła gięcia w kN/1 m długości gięcia											
	a	Minimalna długość kołnierza w mm											
0,5	25												
	4,3												
0,8	70	48											
	4,6	5,7											
1	115	80	60										
	5	6	7										
1,2		120	90	70									
		6	7,5	8,5									
1,5			150	120									
			8	9									
2,0				235	160	135	120	95					
				10	12	13	14,5	17					
2,5					265	225	200	155	110				
					12,5	14	15,5	17,5	23				
3,0							300	240	165	125			
							15,5	17,5	23,5	28			
4,0									315	235	180		
									25	29	35		
5,0									535	430	310	250	
									26	31	35,5	43	
6,0										610	450	360	
										32	36	44	
8,0											880	690	470
											40	46	57
10												800	
												60	
12												1200	
												62	
16													
18													
20													

Arkusze z zanieczyszczeniami hutniczymi zwiększą siłę gięcia o wartość współczynnika 1,05–1,1



100	120	130	140	150	160	180	190	200	230	260	290	320	V
15,5	19	21	23	24,5	26	28	30	32	36	40	45	50	R
F													t
Siła gięcia w kN/1 m długości gięcia													
a													
Minimalna długość kołnierza w mm													
													0,5
													0,8
													1
													1,2
													1,5
													2,0
													2,5
													3,0
													4,0
													5,0
													6,0
360													8,0
71													10
600	470	430	390										12
71	85	92	100										16
900	710	650	580	550	500								18
73	86	92	100	105	115								20
	1400	1250	1150	1050	950	810	800	710	600				
	90	98	105	110	115	130	135	140	160				
			1480	1350	1250	1100	1000	950	800	700	600		
			105	110	120	130	135	140	160	180	205		
						1400	1300	1200	1000	900	850	700	
						135	140	145	165	180	205	225	

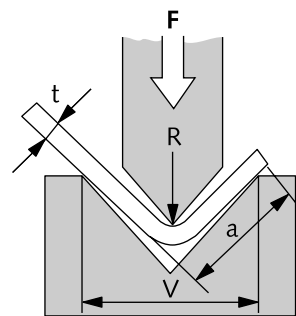

Promień wewnętrzny R odpowiada w przybliżeniu 16% otwarcia matrycy V.



Podstawy obliczania gięcia powietrznego

Wzory obliczeniowe

Zalecane otwarcie matrycy V dla gięcia powietrznego

Grubość materiału	t	0,5–2,5 mm	3–8 mm	9–10 mm	> 12 mm
Otwarcie matrycy	V	6 × t	8 × t	10 × t	12 × t

Siła gięcia dla

Aluminium	Rm = 300 N/mm ²	F = F (stół) × 0,65
Stal konstrukcyjna	Rm = 420 N/mm ²	F = F (stół)
Stal nierdzewna	Rm = 700 N/mm ²	F = F (stół) × 1,6

Ustalanie siły gięcia dla gięcia powietrznego (dane referencyjne)

$$F = \frac{R_m \times t^2}{V} \times \left(1 + \frac{4 \times t}{V}\right)$$

Konwersja: Rm = siła rozciągania w N/mm²

$$10 \text{ N} = 1 \text{ Kg}$$

$$10 \text{ kN} = 1 \text{ t}$$

Konwersja dla minimalnych promieni wewnętrznych R

grubość t	1	2	3	4	5	6	8	10	12	16	18	20
min. R	1	2	3	5	6	8	12	16	20	28	36	40



Siła rozciągania

Materiał		Siła rozciągania	
amerykański	europejski	KPSI	N/mm ²
Aluminium 6061	Alu 50	42	290
Aluminium 5052	Alu 35	44	303
Stal konstrukcyjna 1010	DC01	53	366
A536-80 G 60-40-18	GGG-40	58	400
A 351 G CF 8	G-X 6CrNi 18 9	65	450
A 572 G50	S 355 MC	80	550
Domex 80	S 420 MC	80	550
A 36	S 235 JR	80	552
Nierdzewna 304	Inox V2A	85	586
Nierdzewna 316	Inox V4A	87	600
A 572 G 65	S 460 MC	95	655
Domex 100	S 500 MC	102	700
Domex 550	S 550 MC	110	760
Domex 600	S 600 MC	119	820
Weldox 700	Weldox 700	123	850
Domex 650	S 650 MC	128	880
Domex 700	S 700 MC	138	950
Niskostopowa 4140	42 CrMo 4	145	1000
Weldox 900	Weldox 900	149	1030
Weldox 960	Weldox 960	154	1060
Hardox 400	Hardox 400	181	1250
Hardox 500	Hardox 500	225	1550

W sprawie gięcia materiałów o dużej wytrzymałości należy skontaktować się z właściwym konsultantem.



Jak przebiega wymiana narzędzi?

Inteligentna automatyzacja zapewnia szybką i precyzyjną wymianę narzędzi

- Oszczędność czasu i większa jakość gięcia, dzięki automatycznej wymianie narzędzi górnych i dolnych
- Precyzyjne i bezbłędne pozycjonowanie zestawów narzędzi w systemie mocowania belek górnych i dolnych, nawet przy dużych narzędziach (do V80/BC i MTC do V120)
- Prosta rozbudowa narzędzia w dowolnym momencie: inteligentna technologia czujników automatycznie wykrywa nowe narzędzia i integruje je z magazynem narzędzi
- Automatyczny obrót narzędzi górnych zwiększa różnorodność zastosowań
- Wysoce ergonomiczna i zwarta konstrukcja ułatwiająca obsługę, ponieważ wszystkie narzędzia wewnątrz maszyny są gotowe do natychmiastowej pracy
- Automatyczne czyszczenie stołu umożliwia precyzyjną i delikatną obróbkę wygiętych elementów



*** Maksymalny ciężar narzędzi:**

Chwytek XTC - maks. 15,0 kg

Chwytek BC/MTC - maks. 25,0 kg



Wycięcia

Narzędzia górne

Narzędzia górne mają wycięcia z tyłu. Stemple asymetryczne, np. P4 i P5 mają również wycięcia z przodu.

Możliwa jest obsługa stempli typu P2, P3, P4, P5, P6, P7, P8, P9, P11 i P900 o wysokości 250 mm. Na zamówienie dostępne są narzędzia o wysokości 350 mm.

Segmentacje zaczynają się od długości 30 mm do 515 mm*.

Narzędzia dolne

Narzędzia dolne mają wycięcia z tyłu. To właśnie umożliwia robotowi obsługę narzędzi.

Dostępne są wkładki matrycy od V6 do V120**.

Długości segmentacji zaczynają się od 50 mm do 515 mm*.



* części o długości 515 mm są dostępne na zamówienie lub w BC/MTC

** wkładki matrycy do V80 mogą być obsługiwane przez XTC
wkładki matrycy do V120 mogą być obsługiwane przez BC/MTC



Segmentacje

obowiązujące dla Xpert Tool Changer, MTC i BC

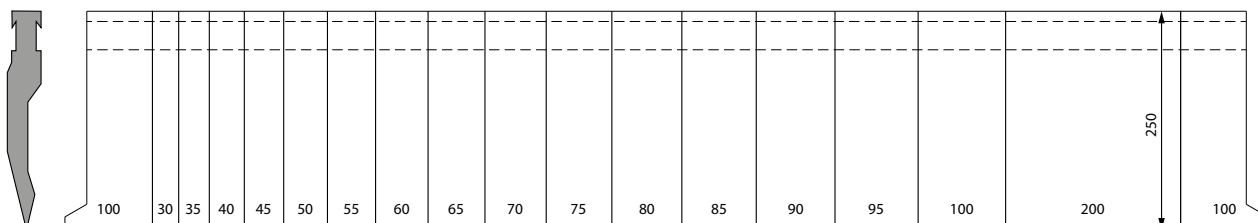

Narzędzia górne	Numer części
Stempel P2 RF-AC/85° H=250 L=1375 odc.	65208.0002.5000
Stempel P4 RF-AC/85° H=250 L=1375 odc.	65208.0004.5000
Stempel P5 RF-AC/30° H=250 L=1375 odc.	65208.0005.5000
Stempel P7 RF-AC/30° H=250 L=1375 odc.	65208.0007.5000

Wszystkie segmentacje składają się z odcinków o następujących długościach:

30 mm, 35 mm, 40 mm, 45 mm, 50 mm, 55 mm, 60 mm, 65 mm, 70 mm, 75 mm, 80 mm, 85 mm, 90 mm, 95 mm, 100 mm, zestaw rogów 100 mm LH + RH

Narzędzia górne	Numer części
Stempel P11 RF-AC B=20 H=250 L=1175 odc.	65208.0011.5000

Segmentacje składają się z odcinków o następujących długościach:

30 mm, 35 mm, 40 mm, 45 mm, 50 mm, 55 mm, 60 mm, 65 mm, 70 mm, 75 mm, 80 mm, 85 mm, 90 mm, 95 mm, 100 mm, 200 mm

Narzędzia dolne	Numer części
Wkładka matrycy, profil płaski V B40 L=1025 odc.	65208.0000.5000

Segmentacje składają się z odcinków o następujących długościach:

50 mm, 55 mm, 60 mm, 65 mm, 70 mm, 75 mm, 80 mm, 85 mm, 90 mm, 95 mm, 100 mm, 200 mm



50	55	60	65	70	75	80	85	90	95	100	200

Narzędzia dolne		Numer części
Wkładka matrycy V6C/30°	L=1025 odc.	64208.0006.5000
Wkładka matrycy V8C/30°	L=1025 odc.	64208.0008.5000
Wkładka matrycy V10C/30°	L=1025 odc.	64208.0010.5000
Wkładka matrycy V12C/30°	L=1025 odc.	64208.0012.5000
Wkładka matrycy V16C/30°	L=1025 odc.	64208.0020.5000
Wkładka matrycy V20C/30°	L=1025 odc.	64208.0020.5000
Wkładka matrycy V24C/30°	L=1025 odc.	64208.0024.5000
Wkładka matrycy V32C/30°	L=1025 odc.	64208.0032.5000
Wkładka matrycy V40C/60°	L=1025 odc.	64208.0040.5000
Wkładka matrycy V50C/60°	L=1025 odc.	64208.0050.5000
Wkładka matrycy V60C/60°	L=1025 odc.	64208.0060.5000
Wkładka matrycy V80C/80°	L=1025 odc.	64208.0080.5000
Wkładka matrycy V100C/80°	L=1025 odc.	64208.0100.5000
Wkładka matrycy V120C/80°	L=1025 odc.	64208.0120.5000
Wkładka matrycy V6SC/30°	L=1025 odc.	64208.0006.5100
Wkładka matrycy V8SC/30°	L=1025 odc.	64208.0008.5100
Wkładka matrycy V10SC/30°	L=1025 odc.	64208.0010.5100
Wkładka matrycy V12SC/30°	L=1025 odc.	64208.0012.5100

Wszystkie segmentacje składają się z odcinków o następujących długościach:

50 mm, 55 mm, 60 mm, 65 mm, 70 mm, 75 mm, 80 mm, 85 mm, 90 mm, 95 mm, 100 mm, 200 mm

*** Narzędzia dolne do V80, są przeznaczone dla XTC**
Narzędzia dolne do V120, są przeznaczone dla BC/MTC



Segmentacje

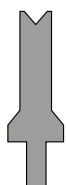

50	55	60	65	70	75	80	85	90	95	100	200

Narzędzia dolne	Numer części
Wkładka matrycy V6C/30° H=100 L=1025 odc.	64208.0006.5031
Wkładka matrycy V8C/30° H=100 L=1025 odc.	64208.0008.5165
Wkładka matrycy V10C/30° H=100 L=1025 odc.	64208.0010.5031
Wkładka matrycy V12C/30° H=100 L=1025 odc.	64208.0012.5030
Wkładka matrycy V16C/30° H=100 L=1025 odc.	64208.0020.5040
Wkładka matrycy V20C/30° H=100 L=1025 odc.	64208.0020.5030
Wkładka matrycy V24C/30° H=100 L=1025 odc.	64208.0024.5031
Wkładka matrycy V32C/30° H=100 L=1025 odc.	64208.0032.5030
Wkładka matrycy V40C/60° H=100 L=1025 odc.	64208.0040.5030
Wkładka matrycy V50C/60° H=100 L=1025 odc.	64208.0050.5030
Wkładka matrycy V60C/60° H=100 L=1025 odc.	64208.0060.5030
Wkładka matrycy V80C/80° H=100 L=1025 odc.	64208.0080.5030

Wszystkie segmentacje składają się z odcinków o następujących długościach:

50 mm, 55 mm, 60 mm, 65 mm, 70 mm, 75 mm, 80 mm, 85 mm, 90 mm, 95 mm,
100 mm, 200 mm

*** Narzędzia dolne do V80, są przeznaczone dla XTC**
Narzędzia dolne do V120, są przeznaczone dla BC/MTC





Narzędzia górne

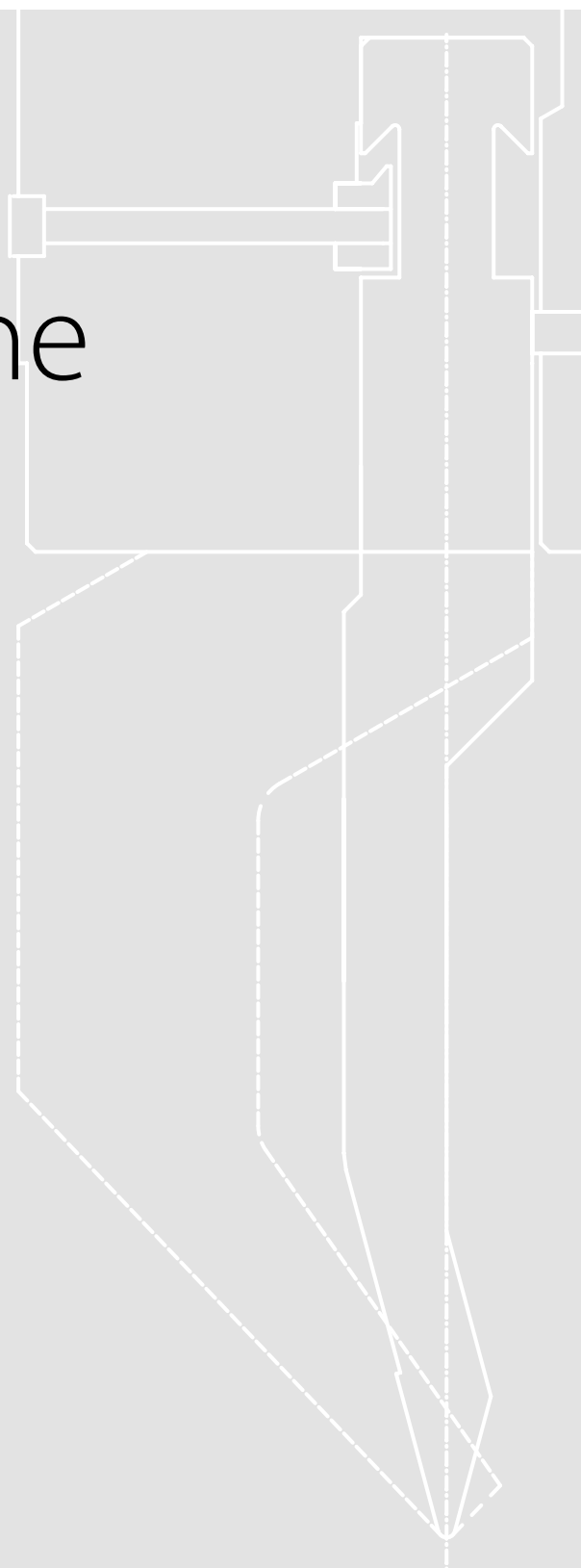

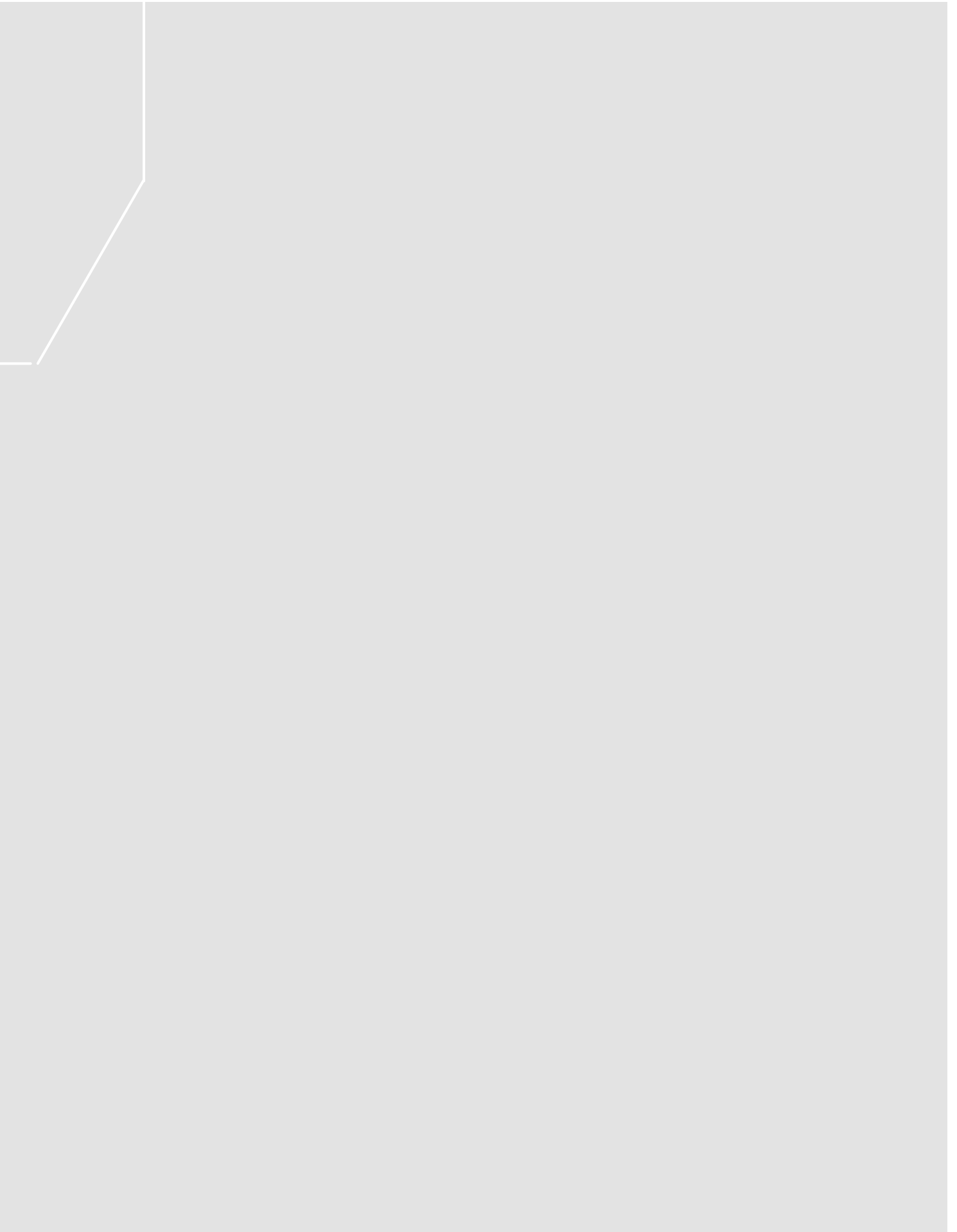



Segmenty narzędzi górnych

Rogi RF-AC

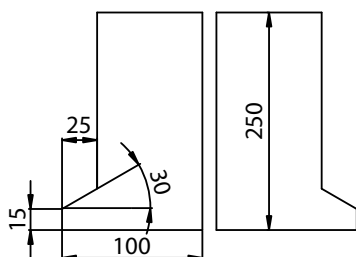

Stempel RF-AC L = 1375 odc.

(30+35+40+45+50+60+65+70+75+80+85+90+95+100+200 +rogi l+r)

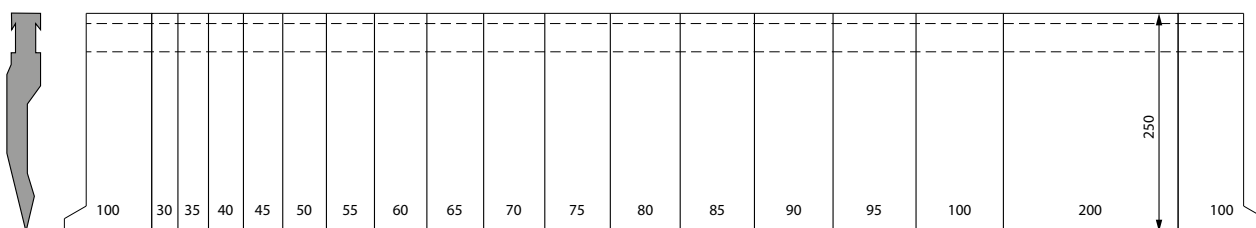

Specjalne segmentacje na zamówienie.

Wszystkie narzędzia górne o innym promieniu są dostępne na zamówienie.

Maksymalny ciężar narzędzi:

Chwytek XTC - maks. 15,0 kg

Chwytek BC/MTC - maks. 25,0 kg



Modular Tool Changer



Bending Cell





P2 RF-AC/85° H250

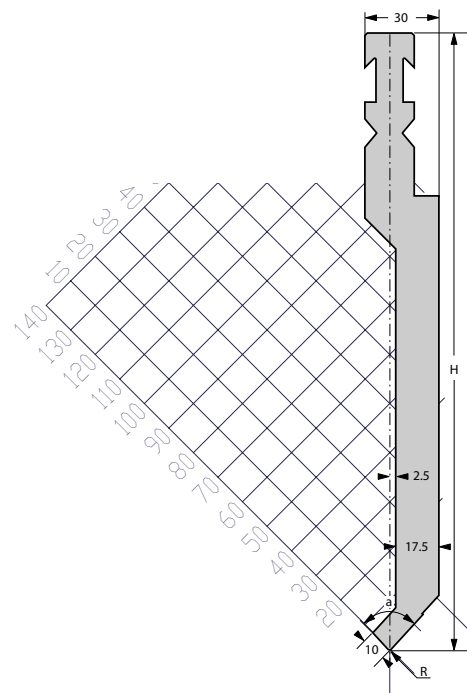

[R] Promień (mm)*	1,0
Kąt naroża	85°
[H] Wysokość (mm)	250

*inny promień na zamówienie

Standardowa długość	Numer części
30 mm	65208.0002.5001
35 mm	65208.0002.5002
40 mm	65208.0002.5003
45 mm	65208.0002.5004
50 mm	65208.0002.5005
55 mm	65208.0002.5006
60 mm	65208.0002.5007
65 mm	65208.0002.5008
70 mm	65208.0002.5015
75 mm	65208.0002.5016
80 mm	65208.0002.5017

Standardowa długość	Numer części
85 mm	65208.0002.5018
90 mm	65208.0002.5019
95 mm	65208.0002.5020
100 mm	65208.0002.5011
200 mm	65208.0002.5012
275 mm	65208.0002.5013
300 mm	65208.0002.5014
515 mm	65208.0002.5019
Zestaw rogów LH + RH	65208.0002.7001
Róg LH	65208.0002.7002
Róg RH	65208.0002.7003



F maks. = 1000 kN/m



34,4 kg/m



98,0 mm



P4 RF-AC/85° H250

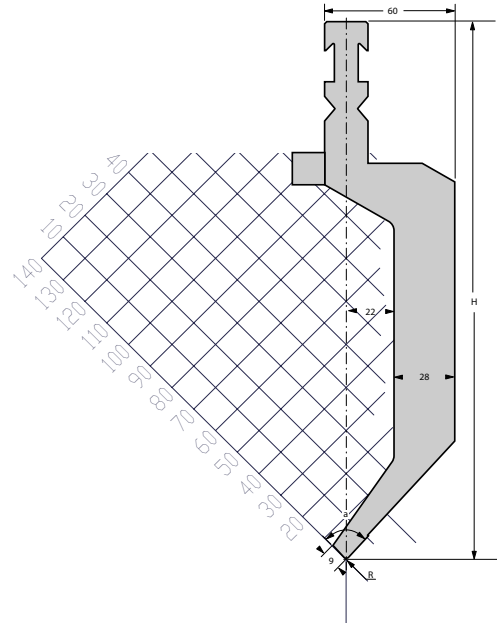

[R] Promień (mm)*	1,5
Kąt naroża	85°
[H] Wysokość (mm)	250

*inny promień na zamówienie

Standardowa długość	Numer części
30 mm	65208.0004.5001
35 mm	65208.0004.5002
40 mm	65208.0004.5003
45 mm	65208.0004.5004
50 mm	65208.0004.5005
55 mm	65208.0004.5006
60 mm	65208.0004.5007
65 mm	65208.0004.5008
70 mm	65208.0004.5015
75 mm	65208.0004.5016
80 mm	65208.0004.5017

Standardowa długość	Numer części
85 mm	65208.0004.5018
90 mm	65208.0004.5019
95 mm	65208.0004.5020
100 mm	65208.0004.5011
200 mm	65208.0004.5012
275 mm	65208.0004.5013
300 mm	65208.0004.5014
Zestaw rogów LH + RH	65208.0004.7003
Róg LH	65208.0004.7001
Róg RH	65208.0004.7002



F maks. = 600 kN/m



48,3 kg/m



98,0 mm



P5 RF-AC/30° H250

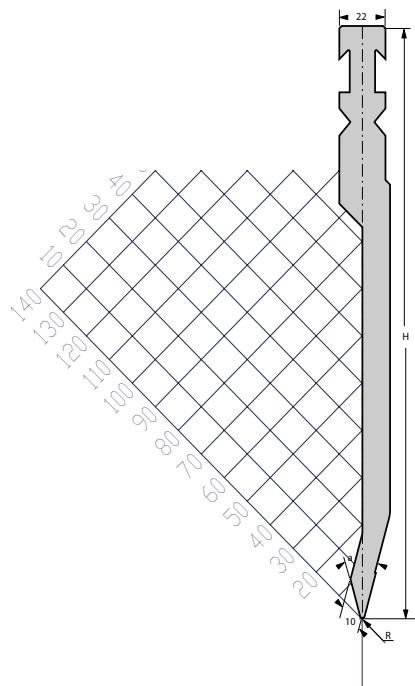

[R] Promień (mm)*	1
Kąt naroża	30°
[H] Wysokość (mm)	250

*inny promień na zamówienie

Standardowa długość	Numer części
30 mm	65208.0005.5001
35 mm	65208.0005.5002
40 mm	65208.0005.5003
45 mm	65208.0005.5004
50 mm	65208.0005.5005
55 mm	65208.0005.5006
60 mm	65208.0005.5007
65 mm	65208.0005.5008
70 mm	65208.0005.5015
75 mm	65208.0005.5016
80 mm	65208.0005.5017

Standardowa długość	Numer części
85 mm	65208.0005.5018
90 mm	65208.0005.5019
95 mm	65208.0005.5020
100 mm	65208.0005.5011
200 mm	65208.0005.5012
275 mm	65208.0005.5013
300 mm	65208.0005.5014
515 mm	65208.0005.5021
Zestaw rogów LH + RH	65208.0005.7003
Róg LH	65208.0005.7001
Róg RH	65208.0005.7002



F maks. = 750 kN/m



26,0 kg/m



98,0 mm



P7 RF-AC/30° H250

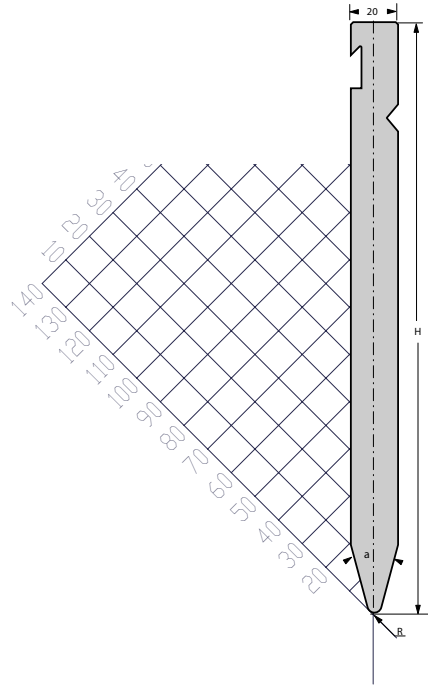

[R] Promień (mm)*	3
Kąt naroża	30°
[H] Wysokość (mm)	250

*inny promień na zamówienie

Standardowa długość	Numer części
30 mm	65208.0007.5001
35 mm	65208.0007.5002
40 mm	65208.0007.5003
45 mm	65208.0007.5004
50 mm	65208.0007.5005
55 mm	65208.0007.5006
60 mm	65208.0007.5007
65 mm	65208.0007.5008
70 mm	65208.0007.5015
75 mm	65208.0007.5016
80 mm	65208.0007.5017

Standardowa długość	Numer części
85 mm	65208.0007.5018
90 mm	65208.0007.5019
95 mm	65208.0007.5020
100 mm	65208.0007.5011
200 mm	65208.0007.5012
275 mm	65208.0007.5013
300 mm	65208.0007.5014
515 mm	65208.0007.5026
Zestaw rogów LH + RH	65208.0007.7003
Róg LH	65208.0007.7001
Róg RH	65208.0007.7002



F maks. = 1400 kN/m



35,9 kg/m



98,0 mm



Matryce

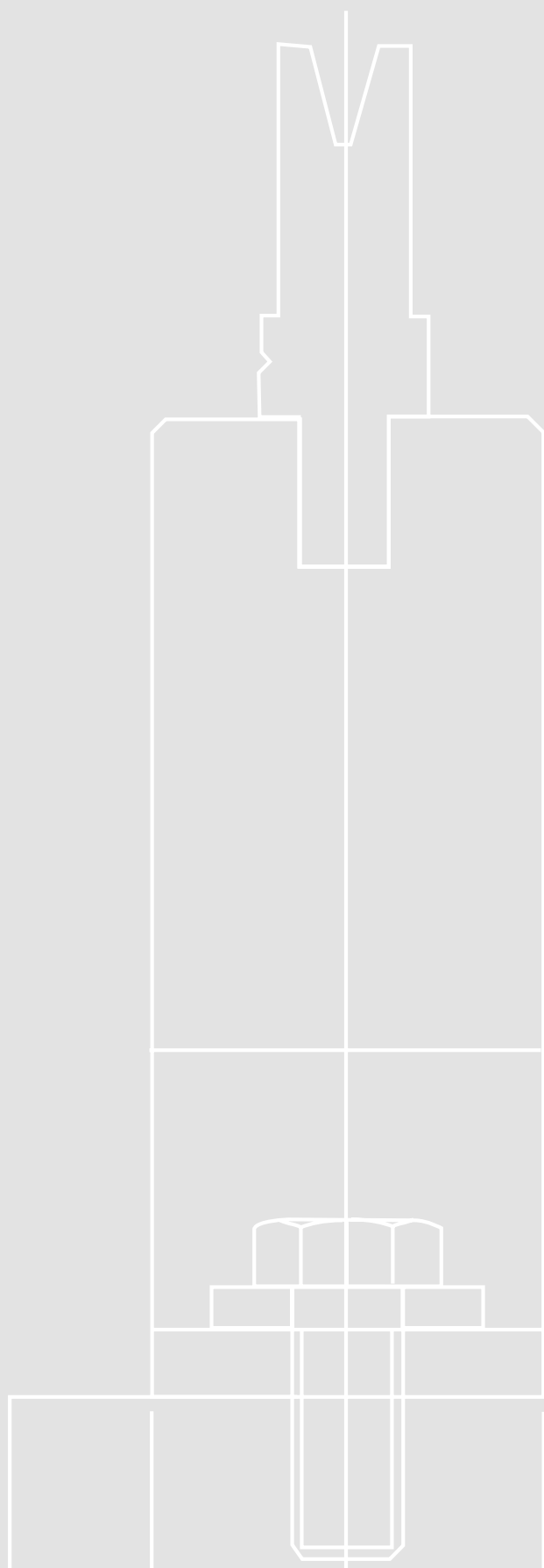





Opcje stołu dolnego

Stół z hydraulicznym mocowaniem narzędzi

T12

(opcjonalne: Xpert 60 - 320 i
Xpert 250 - 1000)

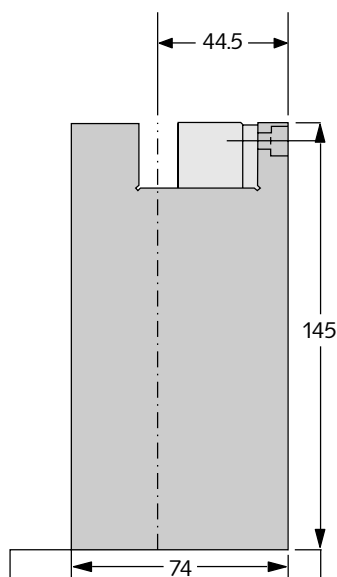

T13

(opcjonalne: Xpert 60 - 320 i
Xpert 250 - 1000)

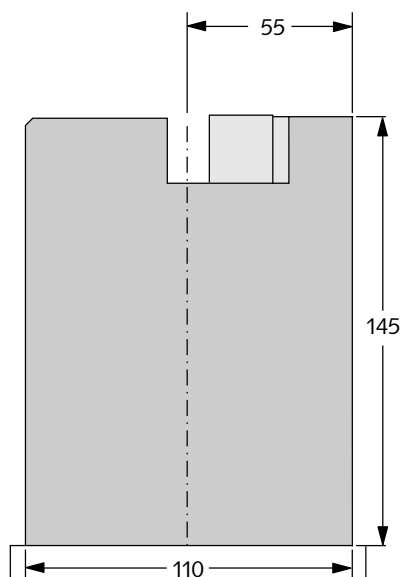



Segmentacja matrycy

Wkładka matrycy VC L = 1025 odc.



50	55	60	65	70	75	80	85	90	95	100	200

Specjalna segmentacja na zamówienie.

Dodatkowo wszystkie narzędzia dolne są dostępne ze zmodyfikowanymi promieniami, kątem i wysokością matrycy (w wersji niestandardowej).



V6C/30° H55

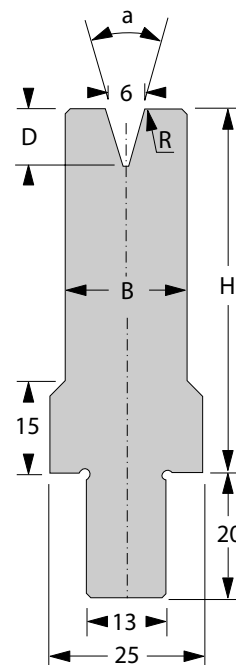

[R] Promień (mm)*	0,75
[a] Kąt V	30°
[H] Wysokość (mm)	55

[B] Szerokość (mm)	20
[D] Głębokość (mm)	9,3

*inny promień na zamówienie

Standardowa długość	Numer części
50 mm	64208.0006.5001
55 mm	64208.0006.5002
60 mm	64208.0006.5003
65 mm	64208.0006.5004
70 mm	64208.0006.5005
75 mm	64208.0006.5006
80 mm	64208.0006.5007
85 mm	64208.0006.5008
90 mm	64208.0006.5009
95 mm	64208.0006.5010
100 mm	64208.0006.5011

Standardowa długość	Numer części
200 mm	64208.0006.5012
275 mm	64208.0006.5013
300 mm	64208.0006.5014
515 mm	64208.0006.5015
1025 mm odc.	64208.0006.5000



F maks. 30° = 400 kN/m



10,9 kg/m



Wkładka matrycy 13 mm



V6C/30° H100

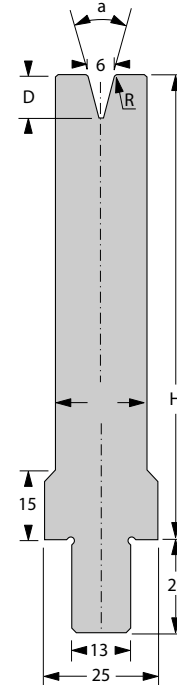

[R] Promień (mm)*	0,75
[a] Kąt V	30°
[H] Wysokość (mm)	100

[B] Szerokość (mm)	20
[D] Głębokość (mm)	9,3

*inny promień na zamówienie

Standardowa długość	Numer części
50 mm	64208.0006.5016
55 mm	64208.0006.5017
60 mm	64208.0006.5018
65 mm	64208.0006.5019
70 mm	64208.0006.5020
75 mm	64208.0006.5021
80 mm	64208.0006.5022
85 mm	64208.0006.5023
90 mm	64208.0006.5024
95 mm	64208.0006.5025
100 mm	64208.0006.5026

Standardowa długość	Numer części
200 mm	64208.0006.5027
275 mm	64208.0006.5028
300 mm	64208.0006.5029
515 mm	64208.0006.5030
1025 mm odc.	64208.0006.5031



F maks. 30° = 400 kN/m



18,0 kg/m



Wkładka matrycy 13 mm



V8C/30° H55

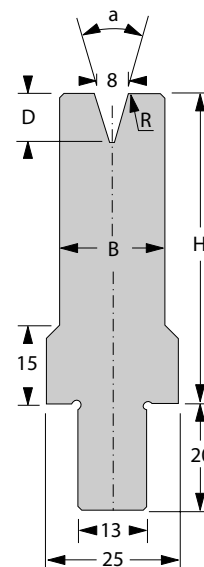

[R] Promień (mm)*	1
[a] Kąt V	30°
[H] Wysokość (mm)	55

[B] Szerokość (mm)	20
[D] Głębokość (mm)	11,2

*inny promień na zamówienie

Standardowa długość	Numer części
50 mm	64208.0008.5001
55 mm	64208.0008.5002
60 mm	64208.0008.5003
65 mm	64208.0008.5004
70 mm	64208.0008.5005
75 mm	64208.0008.5006
80 mm	64208.0008.5007
85 mm	64208.0008.5008
90 mm	64208.0008.5009
95 mm	64208.0008.5010
100 mm	64208.0008.5011

Standardowa długość	Numer części
200 mm	64208.0008.5012
275 mm	64208.0008.5013
300 mm	64208.0008.5014
515 mm	64208.0008.5015
1025 mm odc.	64208.0008.5000



F maks. 30° = 400 kN/m



10,8 kg/m



Wkładka matrycy 13 mm



V8C/30° H100

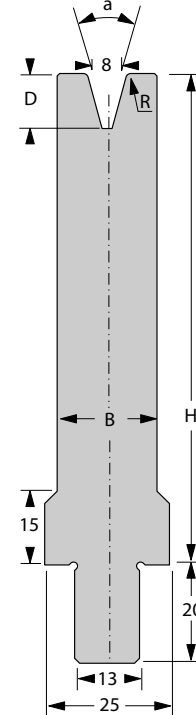

[R] Promień (mm)*	1
[a] Kąt V	30°
[H] Wysokość (mm)	100

[B] Szerokość (mm)	20
[D] Głębokość (mm)	11,2

*inny promień na zamówienie

Standardowa długość	Numer części
50 mm	64208.0008.5016
55 mm	64208.0008.5017
60 mm	64208.0008.5018
65 mm	64208.0008.5019
70 mm	64208.0008.5020
75 mm	64208.0008.5021
80 mm	64208.0008.5022
85 mm	64208.0008.5023
90 mm	64208.0008.5024
95 mm	64208.0008.5025
100 mm	64208.0008.5026

Standardowa długość	Numer części
200 mm	64208.0008.5027
275 mm	64208.0008.5028
300 mm	64208.0008.5029
515 mm	64208.0008.5030
1025 mm odc.	64208.0008.5165



F maks. 30° = 300 kN/m



17,8 kg/m



Wkładka matrycy 13 mm



V10C/30° H55

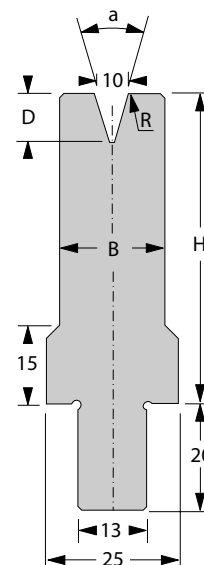
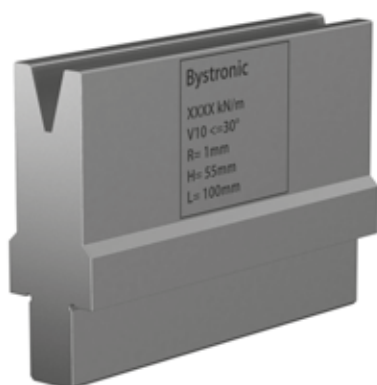

[R] Promień (mm)*	1
[a] Kąt V	30°
[H] Wysokość (mm)	55

[B] Szerokość (mm)	20
[D] Głębokość (mm)	14,9

*inny promień na zamówienie

Standardowa długość	Numer części
50 mm	64208.0010.5001
55 mm	64208.0010.5002
60 mm	64208.0010.5003
65 mm	64208.0010.5004
70 mm	64208.0010.5005
75 mm	64208.0010.5006
80 mm	64208.0010.5007
85 mm	64208.0010.5008
90 mm	64208.0010.5009
95 mm	64208.0010.5010
100 mm	64208.0010.5011

Standardowa długość	Numer części
200 mm	64208.0010.5012
275 mm	64208.0010.5013
300 mm	64208.0010.5014
515 mm	64208.0010.5015
1025 mm odc.	64208.0010.5000



F maks. 30° = 200 kN/m



10,6 kg/m



Wkładka matrycy 13 mm



V10C/30° H100

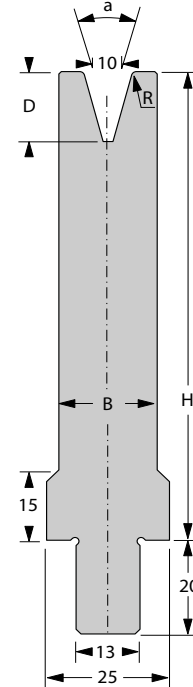

[R] Promień (mm)*	1
[a] Kąt V	30°
[H] Wysokość (mm)	100

[B] Szerokość (mm)	20
[D] Głębokość (mm)	14,9

*inny promień na zamówienie

Standardowa długość	Numer części
50 mm	64208.0010.5016
55 mm	64208.0010.5017
60 mm	64208.0010.5018
65 mm	64208.0010.5019
70 mm	64208.0010.5020
75 mm	64208.0010.5021
80 mm	64208.0010.5022
85 mm	64208.0010.5023
90 mm	64208.0010.5024
95 mm	64208.0010.5025
100 mm	64208.0010.5026

Standardowa długość	Numer części
200 mm	64208.0010.5027
275 mm	64208.0010.5028
300 mm	64208.0010.5029
515 mm	64208.0010.5030
1025 mm odc.	64208.0010.5031



F maks. 30° = 200 kN/m



17,6 kg/m



Wkładka matrycy 13 mm



V12C/30° H55

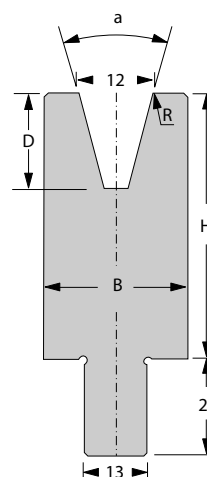

[R] Promień (mm)*	1,5
[a] Kąt V	30°
[H] Wysokość (mm)	55

[B] Szerokość (mm)	25
[D] Głębokość (mm)	18,6

*inny promień na zamówienie

Standardowa długość	Numer części
50 mm	64208.0012.5001
55 mm	64208.0012.5002
60 mm	64208.0012.5003
65 mm	64208.0012.5004
70 mm	64208.0012.5005
75 mm	64208.0012.5006
80 mm	64208.0012.5007
85 mm	64208.0012.5008
90 mm	64208.0012.5009
95 mm	64208.0012.5010
100 mm	64208.0012.5011

Standardowa długość	Numer części
200 mm	64208.0012.5012
275 mm	64208.0012.5013
300 mm	64208.0012.5014
515 mm	64208.0012.5015
1025 mm odc.	64208.0012.5000



F maks. 30° = 250 kN/m



11,8 kg/m



Wkładka matrycy 13 mm



V12C/30° H100

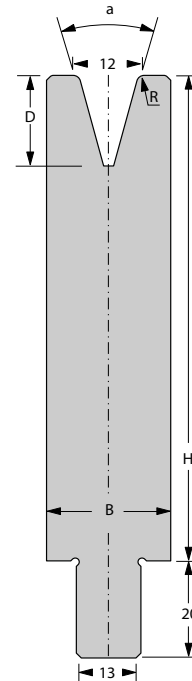

[R] Promień (mm)*	1,5
[a] Kąt V	30°
[H] Wysokość (mm)	100

[B] Szerokość (mm)	25
[D] Głębokość (mm)	18,6

*inny promień na zamówienie

Standardowa długość	Numer części
50 mm	64208.0012.5017
55 mm	64208.0012.5018
60 mm	64208.0012.5019
65 mm	64208.0012.5020
70 mm	64208.0012.5021
75 mm	64208.0012.5022
80 mm	64208.0012.5023
85 mm	64208.0012.5024
90 mm	64208.0012.5025
95 mm	64208.0012.5026
100 mm	64208.0012.5027

Standardowa długość	Numer części
200 mm	64208.0012.5028
275 mm	64208.0012.5029
300 mm	64208.0012.5016
515 mm	64208.0012.5031
1025 mm odc.	64208.0012.5030



F maks. 30° = 250 kN/m



20,6 kg/m



Wkładka matrycy 13 mm



V16C/30° H55

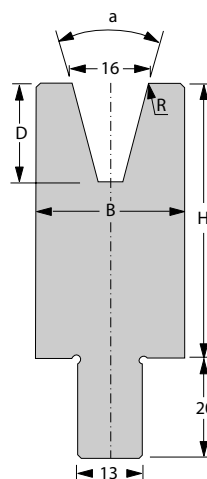

[R] Promień (mm)*	2
[a] Kąt V	30°
[H] Wysokość (mm)	55

[B] Szerokość (mm)	30
[D] Głębokość (mm)	20,5

*inny promień na zamówienie

Standardowa długość	Numer części
50 mm	64208.0016.5001
55 mm	64208.0016.5002
60 mm	64208.0016.5003
65 mm	64208.0016.5004
70 mm	64208.0016.5005
75 mm	64208.0016.5006
80 mm	64208.0016.5007
85 mm	64208.0016.5008
90 mm	64208.0016.5009
95 mm	64208.0016.5010
100 mm	64208.0016.5011

Standardowa długość	Numer części
200 mm	64208.0016.5012
275 mm	64208.0016.5013
300 mm	64208.0016.5014
515 mm	64208.0016.5015
1025 mm odc.	64208.0016.5000



F maks. 30° = 250 kN/m



13,3 kg/m



Wkładka matrycy 13 mm



V16C/30° H100

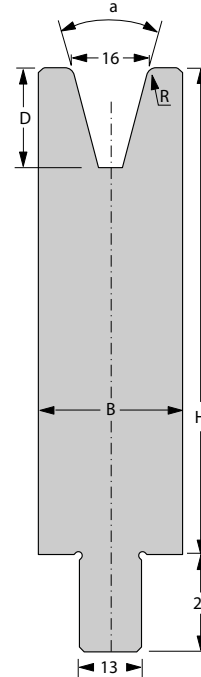

[R] Promień (mm)*	2
[a] Kąt V	30°
[H] Wysokość (mm)	100

[B] Szerokość (mm)	30
[D] Głębokość (mm)	20,5

*inny promień na zamówienie

Standardowa długość	Numer części
50 mm	64208.0016.5016
55 mm	64208.0016.5017
60 mm	64208.0016.5018
65 mm	64208.0016.5019
70 mm	64208.0016.5020
75 mm	64208.0016.5021
80 mm	64208.0016.5022
85 mm	64208.0016.5023
90 mm	64208.0016.5024
95 mm	64208.0016.5025
100 mm	64208.0016.5026

Standardowa długość	Numer części
200 mm	64208.0016.5027
275 mm	64208.0016.5028
300 mm	64208.0016.5029
515 mm	64208.0016.5030
1025 mm odc.	64208.0016.5040



F maks. 30° = 250 kN/m



23,9 kg/m



Wkładka matrycy 13 mm



V20C/30° H55

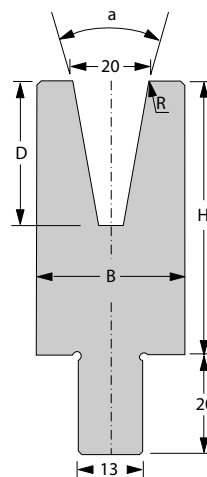

[R] Promień (mm)*	2,5
[a] Kąt V	30°
[H] Wysokość (mm)	55

[B] Szerokość (mm)	30
[D] Głębokość (mm)	28

*inny promień na zamówienie

Standardowa długość	Numer części
50 mm	64208.0020.5001
55 mm	64208.0020.5002
60 mm	64208.0020.5003
65 mm	64208.0020.5004
70 mm	64208.0020.5005
75 mm	64208.0020.5006
80 mm	64208.0020.5007
85 mm	64208.0020.5008
90 mm	64208.0020.5009
95 mm	64208.0020.5010
100 mm	64208.0020.5011

Standardowa długość	Numer części
200 mm	64208.0020.5012
275 mm	64208.0020.5013
300 mm	64208.0020.5014
515 mm	64208.0020.5015
1025 mm odc.	64208.0020.5000



F maks. 30° = 150 kN/m



12,2 kg/m



Wkładka matrycy 13 mm



V20C/30° H100

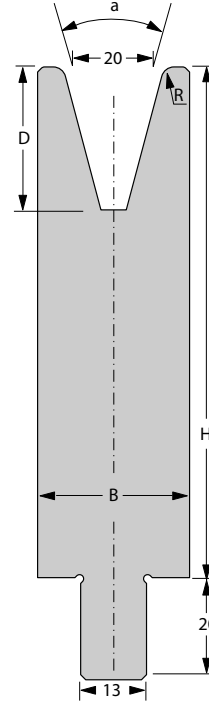

[R] Promień (mm)*	2,5
[a] Kąt V	30°
[H] Wysokość (mm)	100

[B] Szerokość (mm)	30
[D] Głębokość (mm)	28

*inny promień na zamówienie

Standardowa długość	Numer części
50 mm	64208.0020.5017
55 mm	64208.0020.5018
60 mm	64208.0020.5019
65 mm	64208.0020.5020
70 mm	64208.0020.5021
75 mm	64208.0020.5022
80 mm	64208.0020.5023
85 mm	64208.0020.5024
90 mm	64208.0020.5025
95 mm	64208.0020.5026
100 mm	64208.0020.5027

Standardowa długość	Numer części
200 mm	64208.0020.5028
275 mm	64208.0020.5029
300 mm	64208.0020.5016
515 mm	64208.0020.5031
1025 mm odc.	64208.0020.5030



F maks. 30° = 150 kN/m



22,8 kg/m



Wkładka matrycy 13 mm



V24C/30° H55

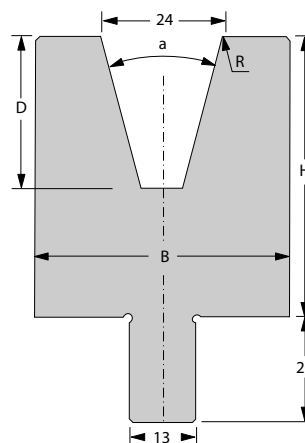

[R] Promień (mm)*	3
[a] Kąt V	30°
[H] Wysokość (mm)	55

[B] Szerokość (mm)	40
[D] Głębokość (mm)	29,8

*inny promień na zamówienie

Standardowa długość	Numer części
50 mm	64208.0024.5001
55 mm	64208.0024.5002
60 mm	64208.0024.5003
65 mm	64208.0024.5004
70 mm	64208.0024.5005
75 mm	64208.0024.5006
80 mm	64208.0024.5007
85 mm	64208.0024.5008
90 mm	64208.0024.5009
95 mm	64208.0024.5010
100 mm	64208.0024.5011

Standardowa długość	Numer części
200 mm	64208.0024.5012
275 mm	64208.0024.5013
300 mm	64208.0024.5014
515 mm	64208.0024.5015
1025 mm odc.	64208.0024.5000



F maks. 30° = 300 kN/m



15,5 kg/m



Wkładka matrycy 13 mm



V24C/30° H100

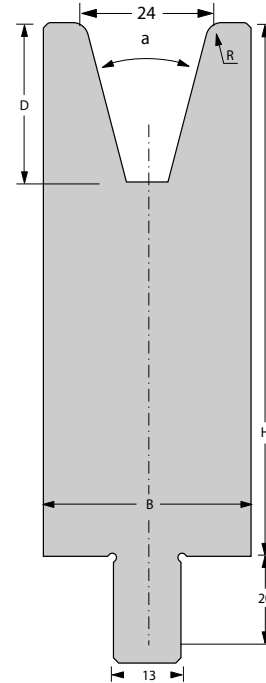

[R] Promień (mm)*	3
[a] Kąt V	30°
[H] Wysokość (mm)	100

[B] Szerokość (mm)	40
[D] Głębokość (mm)	29,8

*inny promień na zamówienie

Standardowa długość	Numer części
50 mm	64208.0024.5016
55 mm	64208.0024.5017
60 mm	64208.0024.5018
65 mm	64208.0024.5019
70 mm	64208.0024.5020
75 mm	64208.0024.5021
80 mm	64208.0024.5022
85 mm	64208.0024.5023
90 mm	64208.0024.5024
95 mm	64208.0024.5025
100 mm	64208.0024.5026

Standardowa długość	Numer części
200 mm	64208.0024.5027
275 mm	64208.0024.5028
300 mm	64208.0024.5029
515 mm	64208.0024.5030
1025 mm odc.	64208.0024.5031



F maks. 30° = 300 kN/m



29,6 kg/m



Wkładka matrycy 13 mm



V32C/30° H55

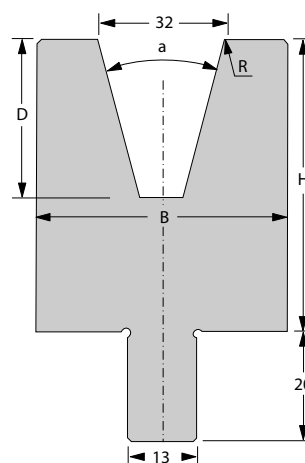
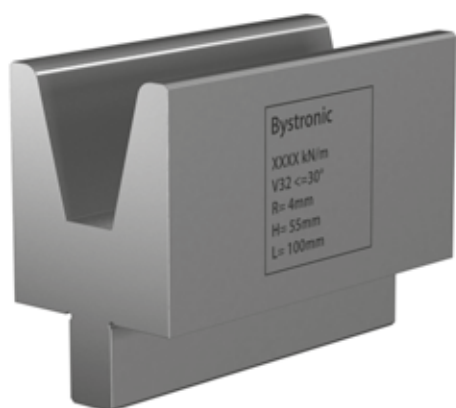

[R] Promień (mm)*	4
[a] Kąt V	30°
[H] Wysokość (mm)	55

[B] Szerokość (mm)	48
[D] Głębokość (mm)	33,6

*inny promień na zamówienie

Standardowa długość	Numer części
50 mm	64208.0032.5001
55 mm	64208.0032.5002
60 mm	64208.0032.5003
65 mm	64208.0032.5004
70 mm	64208.0032.5005
75 mm	64208.0032.5006
80 mm	64208.0032.5007
85 mm	64208.0032.5008
90 mm	64208.0032.5009
95 mm	64208.0032.5010
100 mm	64208.0032.5011

Standardowa długość	Numer części
200 mm	64208.0032.5012
275 mm	64208.0032.5013
300 mm	64208.0032.5014
515 mm	64208.0032.5015
1025 mm odc.	64208.0032.5000



F maks. 30° = 300 kN/m



16,7 kg/m



Wkładka matrycy 13 mm



V32C/30° H100

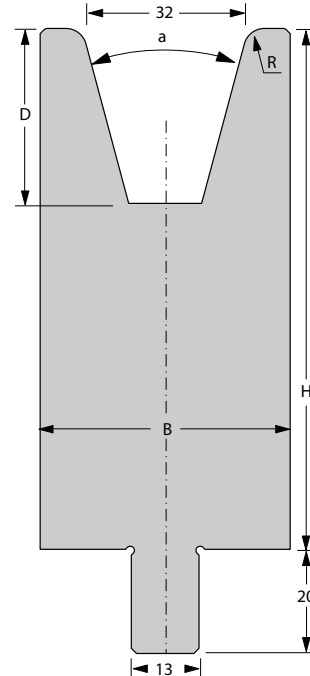

[R] Promień (mm)*	4
[a] Kąt V	30°
[H] Wysokość (mm)	100

[B] Szerokość (mm)	48
[D] Głębokość (mm)	33,6

*inny promień na zamówienie

Standardowa długość	Numer części
50 mm	64208.0032.5017
55 mm	64208.0032.5018
60 mm	64208.0032.5019
65 mm	64208.0032.5020
70 mm	64208.0032.5021
75 mm	64208.0032.5022
80 mm	64208.0032.5023
85 mm	64208.0032.5024
90 mm	64208.0032.5025
95 mm	64208.0032.5026
100 mm	64208.0032.5027

Standardowa długość	Numer części
200 mm	64208.0032.5028
275 mm	64208.0032.5029
300 mm	64208.0032.5016
515 mm	64208.0032.5031
1025 mm odc.	64208.0032.5030



F maks. 30° = 300 kN/m



33,7 kg/m



Wkładka matrycy 13 mm



V40C/60° H55

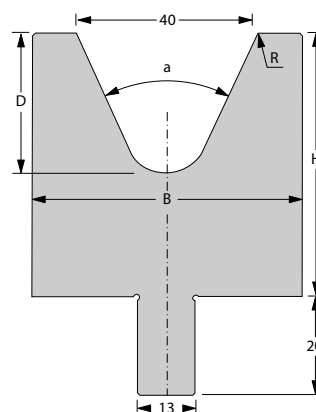
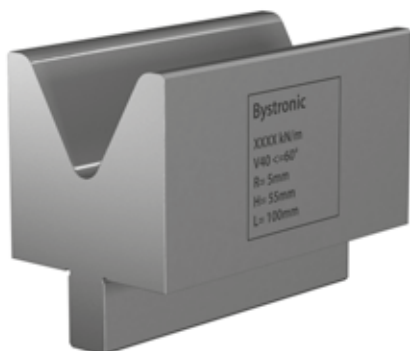

[R] Promień (mm)*	5
[a] Kąt V	60°
[H] Wysokość (mm)	55

[B] Szerokość (mm)	55
[D] Głębokość (mm)	29,6

*inny promień na zamówienie

Standardowa długość	Numer części
50 mm	64208.0040.5001
55 mm	64208.0040.5002
60 mm	64208.0040.5003
65 mm	64208.0040.5004
70 mm	64208.0040.5005
75 mm	64208.0040.5006
80 mm	64208.0040.5007
85 mm	64208.0040.5008
90 mm	64208.0040.5009
95 mm	64208.0040.5010
100 mm	64208.0040.5011

Standardowa długość	Numer części
200 mm	64208.0040.5012
275 mm	64208.0040.5013
300 mm	64208.0040.5014
515 mm	64208.0040.5015
1025 mm odc.	64208.0040.5000



F maks. 60° = 1800 kN/m



20,5 kg/m



Wkładka matrycy 13 mm



V40C/60° H100

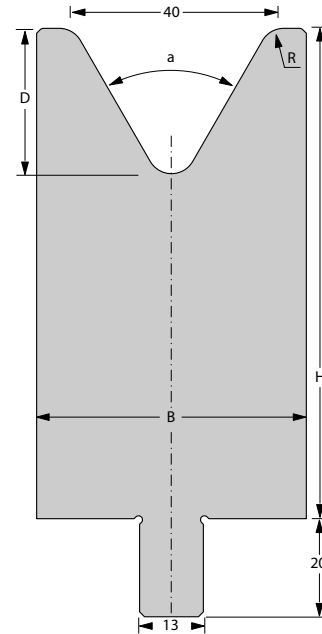

[R] Promień (mm)*	5
[a] Kąt V	60°
[H] Wysokość (mm)	100

[B] Szerokość (mm)	55
[D] Głębokość (mm)	29,6

*inny promień na zamówienie

Standardowa długość	Numer części
50 mm	64208.0040.5017
55 mm	64208.0040.5018
60 mm	64208.0040.5019
65 mm	64208.0040.5020
70 mm	64208.0040.5021
75 mm	64208.0040.5022
80 mm	64208.0040.5023
85 mm	64208.0040.5024
90 mm	64208.0040.5025
95 mm	64208.0040.5026
100 mm	64208.0040.5027

Standardowa długość	Numer części
200 mm	64208.0040.5028
275 mm	64208.0040.5029
300 mm	64208.0040.5016
515 mm	64208.0040.5031
1025 mm odc.	64208.0040.5030



F maks. 60° = 1300 kN/m



39,9 kg/m



Wkładka matrycy 13 mm



V50C/60° H55

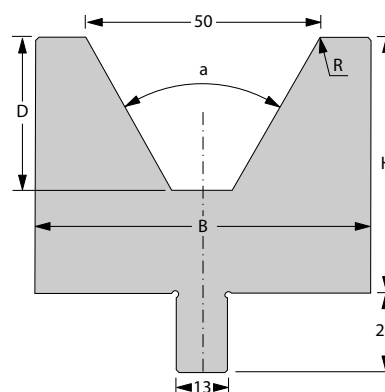
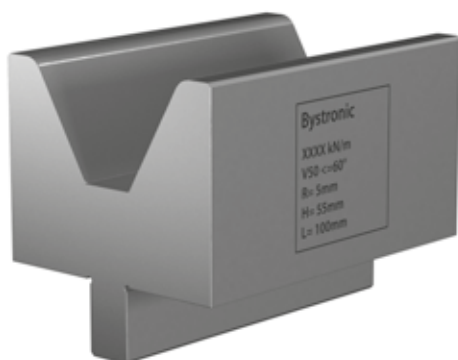

[R] Promień (mm)*	5
[a] Kąt V	60°
[H] Wysokość (mm)	55

[B] Szerokość (mm)	70
[D] Głębokość (mm)	30,3

*inny promień na zamówienie

Standardowa długość	Numer części
50 mm	64208.0050.5001
55 mm	64208.0050.5002
60 mm	64208.0050.5003
65 mm	64208.0050.5004
70 mm	64208.0050.5005
75 mm	64208.0050.5006
80 mm	64208.0050.5007
85 mm	64208.0050.5008
90 mm	64208.0050.5009
95 mm	64208.0050.5010
100 mm	64208.0050.5011

Standardowa długość	Numer części
200 mm	64208.0050.5012
275 mm	64208.0050.5013
300 mm	64208.0050.5014
515 mm	64208.0050.5015
1025 mm odc.	64208.0050.5000



F maks. 60° = 1200 kN/m



24,5 kg/m



Wkładka matrycy 13 mm



V50C/60° H100

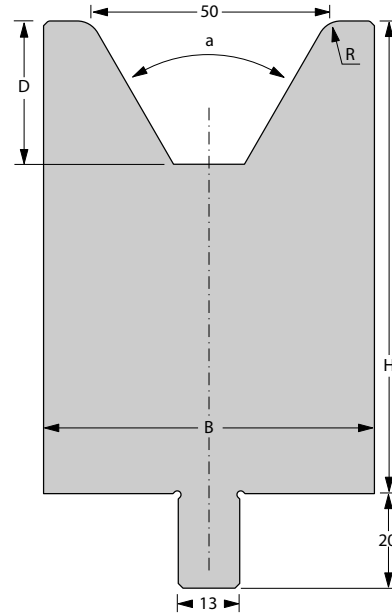

[R] Promień (mm)*	5
[a] Kąt V	60°
[H] Wysokość (mm)	100

[B] Szerokość (mm)	70
[D] Głębokość (mm)	30,3

*inny promień na zamówienie

Standardowa długość	Numer części
50 mm	64208.0050.5016
55 mm	64208.0050.5017
60 mm	64208.0050.5018
65 mm	64208.0050.5019
70 mm	64208.0050.5020
75 mm	64208.0050.5021
80 mm	64208.0050.5022
85 mm	64208.0050.5023
90 mm	64208.0050.5024
95 mm	64208.0050.5025
100 mm	64208.0050.5026

Standardowa długość	Numer części
200 mm	64208.0050.5027
275 mm	64208.0050.5028
300 mm	64208.0050.5029
515 mm	64208.0050.5031
1025 mm odc.	64208.0050.5030



F maks. 60° = 2000 kN/m



49,2 kg/m



Wkładka matrycy 13 mm



V60C/60° H65

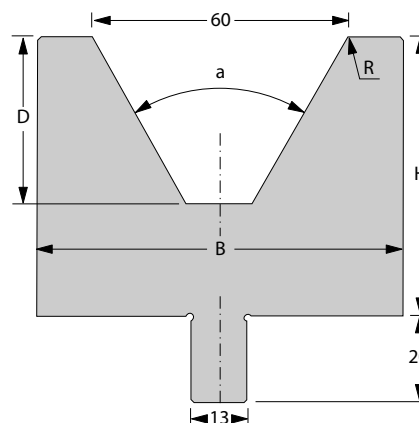
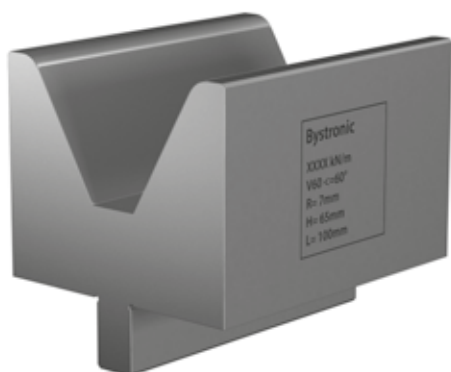

[R] Promień (mm)*	7
[a] Kąt V	60°
[H] Wysokość (mm)	65

[B] Szerokość (mm)	80
[D] Głębokość (mm)	39

*inny promień na zamówienie

Standardowa długość	Numer części
50 mm	64208.0060.5001
55 mm	64208.0060.5002
60 mm	64208.0060.5003
65 mm	64208.0060.5004
70 mm	64208.0060.5005
75 mm	64208.0060.5006
80 mm	64208.0060.5007
85 mm	64208.0060.5008
90 mm	64208.0060.5009
95 mm	64208.0060.5010
100 mm	64208.0060.5011

Standardowa długość	Numer części
200 mm	64208.0060.5012
275 mm	64208.0060.5013
300 mm	64208.0060.5014
515 mm	64208.0060.5031
1025 mm odc.	64208.0060.5000



F maks. 60° = 1600 kN/m



31,4 kg/m



Wkładka matrycy 13 mm



V60C/60° H100

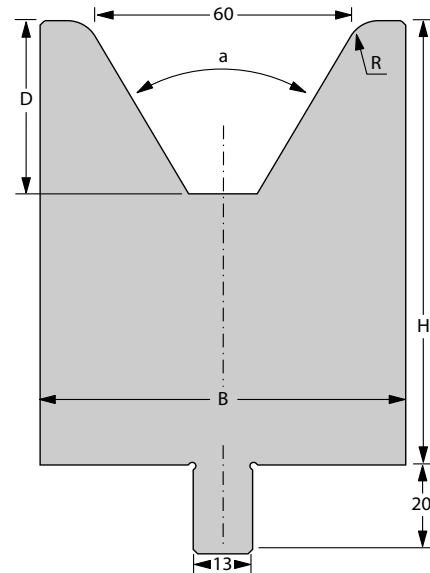

[R] Promień (mm)*	7
[a] Kąt V	60°
[H] Wysokość (mm)	100

[B] Szerokość (mm)	80
[D] Głębokość (mm)	39

*inny promień na zamówienie

Standardowa długość	Numer części
50 mm	64208.0060.5016
55 mm	64208.0060.5017
60 mm	64208.0060.5018
65 mm	64208.0060.5019
70 mm	64208.0060.5020
75 mm	64208.0060.5021
80 mm	64208.0060.5022
85 mm	64208.0060.5023
90 mm	64208.0060.5024
95 mm	64208.0060.5025
100 mm	64208.0060.5026

Standardowa długość	Numer części
200 mm	64208.0060.5015
275 mm	64208.0060.5027
300 mm	64208.0060.5028
1025 mm odc.	64208.0060.5030



F maks. 60° = 2000 kN/m



53,4 kg/m



Wkładka matrycy 13 mm



V80C/80° H65

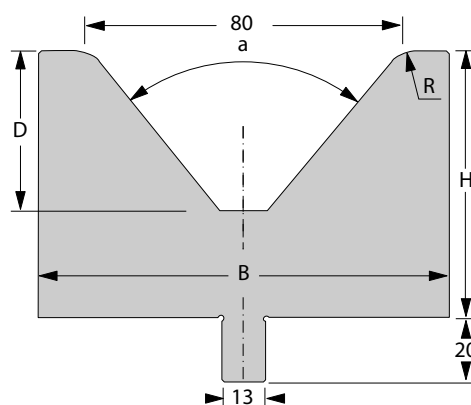
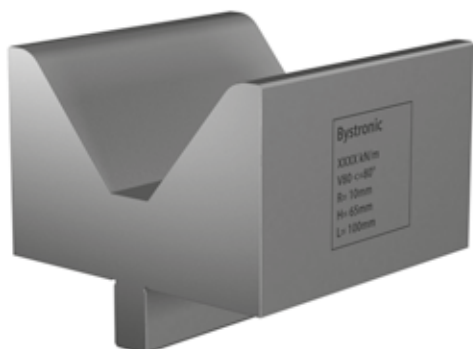

[R] Promień (mm)*	10
[a] Kąt V	80°
[H] Wysokość (mm)	65

[B] Szerokość (mm)	100
[D] Głębokość (mm)	38,7

*inny promień na zamówienie

Standardowa długość	Numer części
50 mm	64208.0080.5001
55 mm	64208.0080.5002
60 mm	64208.0080.5003
65 mm	64208.0080.5004
70 mm	64208.0080.5005
75 mm	64208.0080.5006
80 mm	64208.0080.5007
85 mm	64208.0080.5008
90 mm	64208.0080.5009
95 mm	64208.0080.5010
100 mm	64208.0080.5011

Standardowa długość	Numer części
200 mm	64208.0080.5012
275 mm	64208.0080.5013
300 mm	64208.0080.5014
515 mm	64208.0080.5029
1025 mm odc.	64208.0080.5000



F maks. 80° = 1400 kN/m



38,6 kg/m



Wkładka matrycy 13 mm



V80C/80° H100

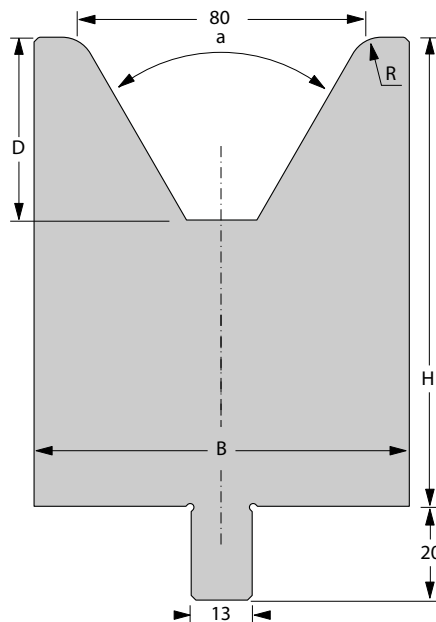

[R] Promień (mm)*	10
[a] Kąt V	80°
[H] Wysokość (mm)	100

[B] Szerokość (mm)	100
[D] Głębokość (mm)	38,7

*inny promień na zamówienie

Standardowa długość	Numer części
50 mm	64208.0080.5015
55 mm	64208.0080.5016
60 mm	64208.0080.5017
65 mm	64208.0080.5018
70 mm	64208.0080.5019
75 mm	64208.0080.5020
80 mm	64208.0080.5021
85 mm	64208.0080.5022
90 mm	64208.0080.5023
95 mm	64208.0080.5024
100 mm	64208.0080.5025

Standardowa długość	Numer części
200 mm	64208.0080.5026
275 mm	64208.0080.5027
300 mm	64208.0080.5028
1025 mm odc.	64208.0080.5030



F maks. 80° = 1400 kN/m



66,0 kg/m



Wkładka matrycy 13 mm



V100C/80° H85

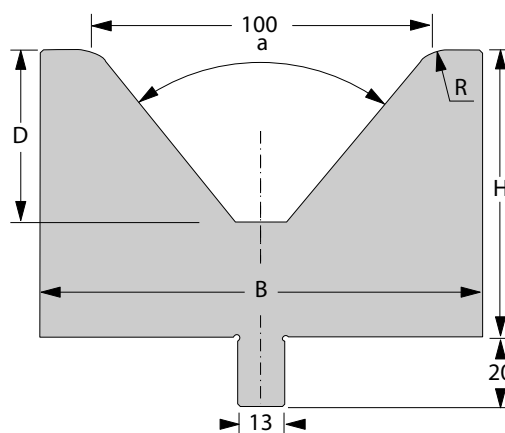
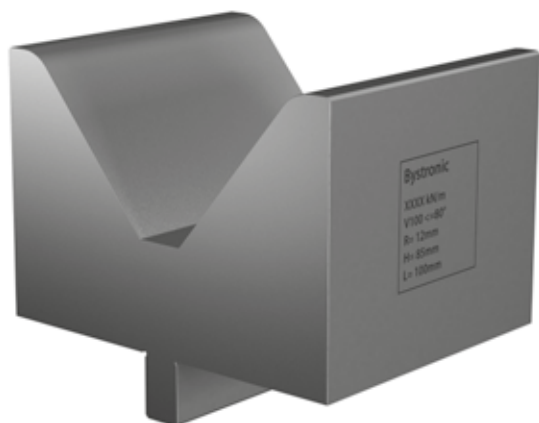

[R] Promień (mm)*	12
[a] Kąt V	80°
[H] Wysokość (mm)	85

[B] Szerokość (mm)	125
[D] Głębokość (mm)	50,5

*inny promień na zamówienie

Standardowa długość	Numer części
50 mm	64208.0100.5001
55 mm	64208.0100.5002
60 mm	64208.0100.5003
65 mm	64208.0100.5004
70 mm	64208.0100.5005
75 mm	64208.0100.5006
80 mm	64208.0100.5007
85 mm	64208.0100.5008
90 mm	64208.0100.5009
95 mm	64208.0100.5010
100 mm	64208.0100.5011

Standardowa długość	Numer części
200 mm	64208.0100.5012
275 mm	64208.0100.5013
300 mm	64208.0100.5014
1025 mm odc.	64208.0100.5000



F maks. 80° = 1800 kN/m



60,5 kg/m



Wkładka matrycy 13 mm



V120C/80° H105

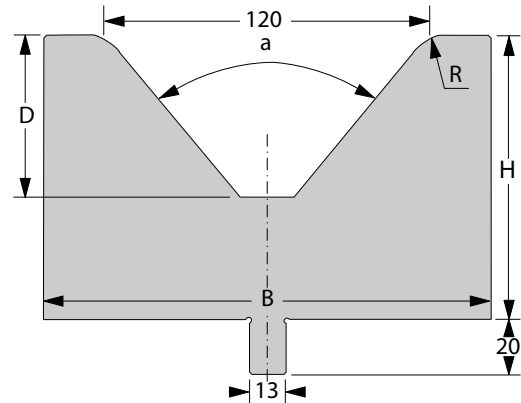
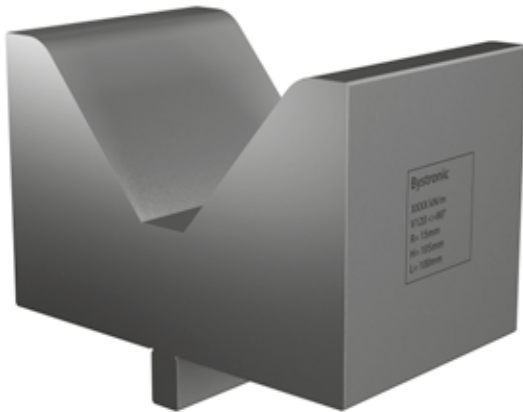

[R] Promień (mm)*	15
[a] Kąt V	80°
[H] Wysokość (mm)	105

[B] Szerokość (mm)	160
[D] Głębokość (mm)	59,5

*inny promień na zamówienie

Standardowa długość	Numer części
50 mm	64208.0120.5001
55 mm	64208.0120.5002
60 mm	64208.0120.5003
65 mm	64208.0120.5004
70 mm	64208.0120.5005
75 mm	64208.0120.5006
80 mm	64208.0120.5007
85 mm	64208.0120.5008
90 mm	64208.0120.5009
95 mm	64208.0120.5010
100 mm	64208.0120.5011

Standardowa długość	Numer części
200 mm	64208.0120.5012
275 mm	64208.0120.5013
300 mm	64208.0120.5014
1025 mm odc.	64208.0120.5000



F maks. 80° = 2000 kN/m



101,0 kg/m



Wkładka matrycy 13 mm



V6SC/30° H55

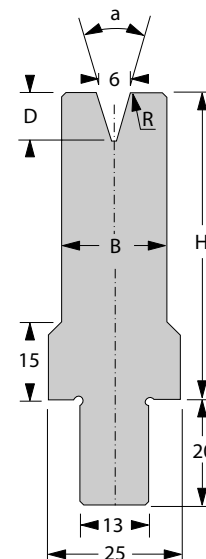

[R] Promień (mm)*	0,75
[a] Kąt V	30°
[H] Wysokość (mm)	55

[B] Szerokość (mm)	12
[D] Głębokość (mm)	9,3

*inny promień na zamówienie

Standardowa długość	Numer części
50 mm	64208.0006.5101
55 mm	64208.0006.5102
60 mm	64208.0006.5103
65 mm	64208.0006.5104
70 mm	64208.0006.5105
75 mm	64208.0006.5106
80 mm	64208.0006.5107
85 mm	64208.0006.5108
90 mm	64208.0006.5109
95 mm	64208.0006.5110
100 mm	64208.0006.5111

Standardowa długość	Numer części
200 mm	64208.0006.5112
275 mm	64208.0006.5113
300 mm	64208.0006.5114
515 mm	64208.0006.5115
1025 mm odc.	64208.0006.5100



F maks. 30° = 100 kN/m



8,1 kg/m



Wkładka matrycy 13 mm



V6SC/30° H100

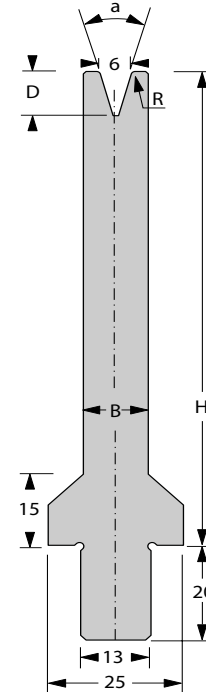

[R] Promień (mm)*	0,75
[a] Kąt V	30°
[H] Wysokość (mm)	100

[B] Szerokość (mm)	12
[D] Głębokość (mm)	9,3

*inny promień na zamówienie

Standardowa długość	Numer części
50 mm	64208.0006.5151
55 mm	64208.0006.5152
60 mm	64208.0006.5153
65 mm	64208.0006.5154
70 mm	64208.0006.5155
75 mm	64208.0006.5156
80 mm	64208.0006.5157
85 mm	64208.0006.5158
90 mm	64208.0006.5159
95 mm	64208.0006.5160
100 mm	64208.0006.5161

Standardowa długość	Numer części
200 mm	64208.0006.5162
275 mm	64208.0006.5163
300 mm	64208.0006.5164
515 mm	64208.0006.5165
1025 mm odc.	64208.0006.5150



F maks. 30° = 100 kN/m



12,3 kg/m



Wkładka matrycy 13 mm



V8SC/30° H55

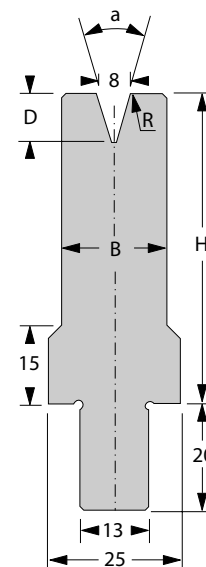

[R] Promień (mm)*	1
[a] Kąt V	30°
[H] Wysokość (mm)	55

[B] Szerokość (mm)	14
[D] Głębokość (mm)	11,2

*inny promień na zamówienie

Standardowa długość	Numer części
50 mm	64208.0008.5102
55 mm	64208.0008.5103
60 mm	64208.0008.5104
65 mm	64208.0008.5105
70 mm	64208.0008.5106
75 mm	64208.0008.5107
80 mm	64208.0008.5108
85 mm	64208.0008.5109
90 mm	64208.0008.5110
95 mm	64208.0008.5111
100 mm	64208.0008.5112

Standardowa długość	Numer części
200 mm	64208.0008.5113
275 mm	64208.0008.5114
300 mm	64208.0008.5115
515 mm	64208.0008.5116
1025 mm odc.	64208.0008.5100



F maks. 30° = 100 kN/m



8,7 kg/m



Wkładka matrycy 13 mm



V8SC/30° H100

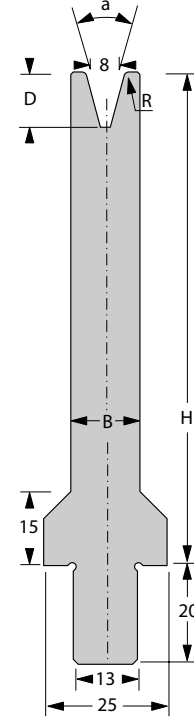

[R] Promień (mm)*	1
[a] Kąt V	30°
[H] Wysokość (mm)	100

[B] Szerokość (mm)	14
[D] Głębokość (mm)	11,2

*inny promień na zamówienie

Standardowa długość	Numer części
50 mm	64208.0008.5151
55 mm	64208.0008.5152
60 mm	64208.0008.5153
65 mm	64208.0008.5154
70 mm	64208.0008.5155
75 mm	64208.0008.5156
80 mm	64208.0008.5157
85 mm	64208.0008.5158
90 mm	64208.0008.5159
95 mm	64208.0008.5160
100 mm	64208.0008.5161

Standardowa długość	Numer części
200 mm	64208.0008.5162
275 mm	64208.0008.5163
300 mm	64208.0008.5164
515 mm	64208.0008.5166
1025 mm odc.	64208.0008.5150



F maks. 30° = 1000 kN/m



13,7 kg/m



Wkładka matrycy 13 mm



V10SC/30° H55

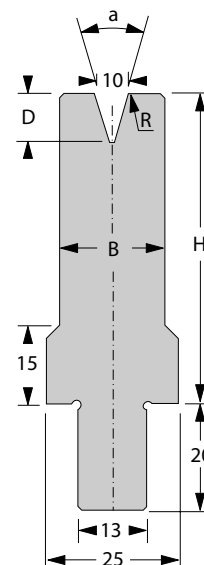

[R] Promień (mm)*	1
[a] Kąt V	30°
[H] Wysokość (mm)	55

[B] Szerokość (mm)	16
[D] Głębokość (mm)	14,9

*inny promień na zamówienie

Standardowa długość	Numer części
50 mm	64208.0010.5101
55 mm	64208.0010.5102
60 mm	64208.0010.5103
65 mm	64208.0010.5104
70 mm	64208.0010.5105
75 mm	64208.0010.5106
80 mm	64208.0010.5107
85 mm	64208.0010.5108
90 mm	64208.0010.5109
95 mm	64208.0010.5110
100 mm	64208.0010.5111

Standardowa długość	Numer części
200 mm	64208.0010.5112
275 mm	64208.0010.5113
300 mm	64208.0010.5114
515 mm	64208.0010.5115
1025 mm odc.	64208.0010.5100



F maks. 30° = 100 kN/m



9,1 kg/m



Wkładka matrycy 13 mm



V10SC/30° H100

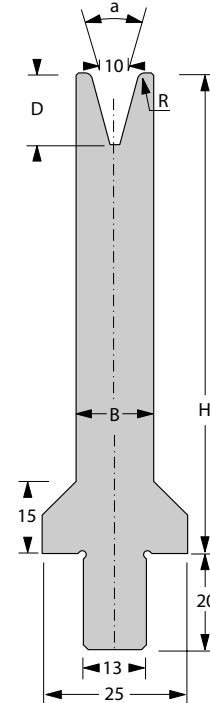

[R] Promień (mm)*	1
[a] Kąt V	30°
[H] Wysokość (mm)	100

[B] Szerokość (mm)	16
[D] Głębokość (mm)	14,9

*inny promień na zamówienie

Standardowa długość	Numer części
50 mm	64208.0010.5117
55 mm	64208.0010.5118
60 mm	64208.0010.5119
65 mm	64208.0010.5120
70 mm	64208.0010.5121
75 mm	64208.0010.5122
80 mm	64208.0010.5123
85 mm	64208.0010.5124
90 mm	64208.0010.5125
95 mm	64208.0010.5126
100 mm	64208.0010.5127

Standardowa długość	Numer części
200 mm	64208.0010.5128
275 mm	64208.0010.5129
300 mm	64208.0010.5130
515 mm	64208.0010.5131
1025 mm odc.	64208.0010.5116



F maks. 30° = 100 kN/m



14,7 kg/m



Wkładka matrycy 13 mm



V12SC/30° H55

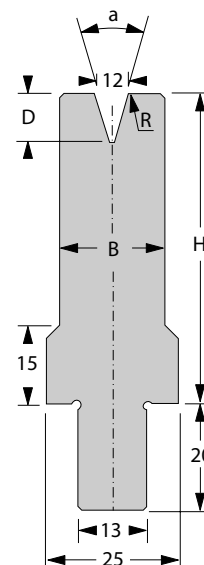
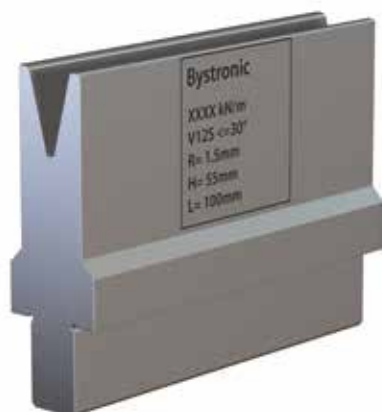

[R] Promień (mm)*	1,5
[a] Kąt V	30°
[H] Wysokość (mm)	55

[B] Szerokość (mm)	18
[D] Głębokość (mm)	18,6

*inny promień na zamówienie

Standardowa długość	Numer części
50 mm	64208.0012.5101
55 mm	64208.0012.5102
60 mm	64208.0012.5103
65 mm	64208.0012.5104
70 mm	64208.0012.5105
75 mm	64208.0012.5106
80 mm	64208.0012.5107
85 mm	64208.0012.5108
90 mm	64208.0012.5109
95 mm	64208.0012.5110
100 mm	64208.0012.5111

Standardowa długość	Numer części
200 mm	64208.0012.5112
275 mm	64208.0012.5113
300 mm	64208.0012.5114
515 mm	64208.0012.5115
1025 mm odc.	64208.0012.5100



F maks. 30° = 100 kN/m



9,5 kg/m



Wkładka matrycy 13 mm



V12SC/30° H100

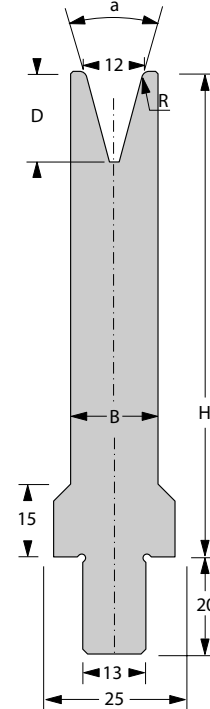

[R] Promień (mm)*	1,5
[a] Kąt V	30°
[H] Wysokość (mm)	100

[B] Szerokość (mm)	18
[D] Głębokość (mm)	18,6

*inny promień na zamówienie

Standardowa długość	Numer części
50 mm	64208.0012.5117
55 mm	64208.0012.5118
60 mm	64208.0012.5119
65 mm	64208.0012.5120
70 mm	64208.0012.5121
75 mm	64208.0012.5122
80 mm	64208.0012.5123
85 mm	64208.0012.5124
90 mm	64208.0012.5125
95 mm	64208.0012.5126
100 mm	64208.0012.5127

Standardowa długość	Numer części
200 mm	64208.0012.5128
275 mm	64208.0012.5129
300 mm	64208.0012.5130
515 mm	64208.0012.5131
1025 mm odc.	64208.0012.5116



F maks. 30° = 100 kN/m



15,9 kg/m



Wkładka matrycy 13 mm



Narzędzia do zaginania

Narzędzia do rozplaszczania

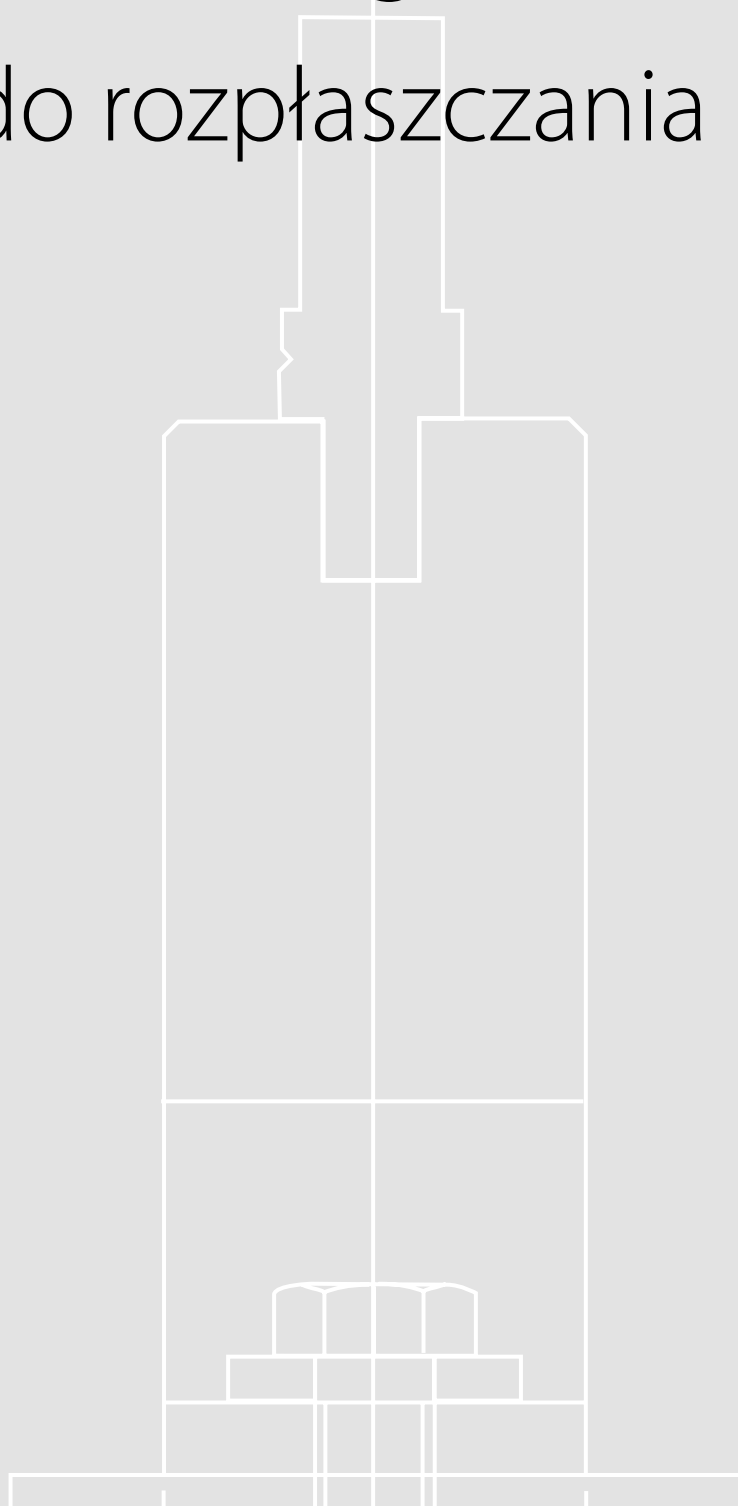





P11 RF-AC H250

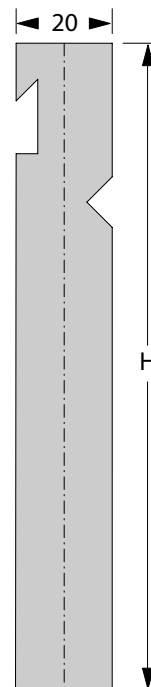

[B] Szerokość (mm) 20

[H] Wysokość (mm) 250

Standardowa długość	Numer części
30 mm	65208.0011.5001
35 mm	65208.0011.5002
40 mm	65208.0011.5003
45 mm	65208.0011.5004
50 mm	65208.0011.5005
55 mm	65208.0011.5006
60 mm	65208.0011.5007
65 mm	65208.0011.5008
70 mm	65208.0011.5009
75 mm	65208.0011.5010
80 mm	65208.0011.5011

Standardowa długość	Numer części
85 mm	65208.0011.5012
90 mm	65208.0011.5013
95 mm	65208.0011.5014
100 mm	65208.0011.5015
200 mm	65208.0011.5016
275 mm	65208.0011.5017
300 mm	65208.0011.5018
515 mm	65208.0011.5023
1175 mm odc.	65208.0011.5000



F maks. = 1400 kN/m



35,9 kg/m



98,0 mm



P900/8 RF-AC/30° H250

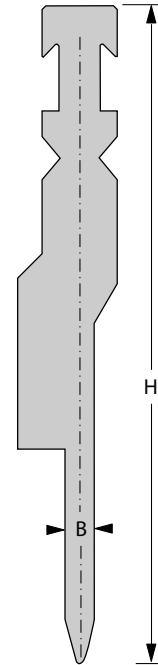

[B] Szerokość (mm) 26,5

[H] Wysokość (mm) 250

Standardowa długość	Numer części
30 mm	65208.0900.5002
35 mm	65208.0900.5003
40 mm	65208.0900.5004
45 mm	65208.0900.5005
50 mm	65208.0900.5006
55 mm	65208.0900.5007
60 mm	65208.0900.5008
65 mm	65208.0900.5009
70 mm	65208.0900.5010
75 mm	65208.0900.5011
80 mm	65208.0900.5012

Standardowa długość	Numer części
85 mm	65208.0900.5013
90 mm	65208.0900.5014
95 mm	65208.0900.5015
100 mm	65208.0900.5016
200 mm	65208.0900.5017
275 mm	65208.0900.5018
300 mm	65208.0900.5019
515 mm	65208.0900.5020
1175 mm odc.	65208.0900.5000



F maks. = 1000 kN/m



29,2 kg/m



P900/10 RF-AC/30° H250

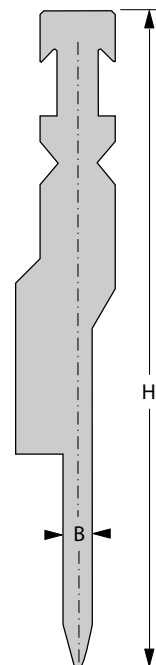

[B] Szerokość (mm) 26,5

[H] Wysokość (mm) 250

Standardowa długość	Numer części
30 mm	65208.0900.5050
35 mm	65208.0900.5041
40 mm	65208.0900.5042
45 mm	65208.0900.5043
50 mm	65208.0900.5044
55 mm	65208.0900.5045
60 mm	65208.0900.5046
65 mm	65208.0900.5047
70 mm	65208.0900.5048
75 mm	65208.0900.5049
80 mm	65208.0900.5040

Standardowa długość	Numer części
85 mm	65208.0900.5051
90 mm	65208.0900.5052
95 mm	65208.0900.5053
100 mm	65208.0900.5054
200 mm	65208.0900.5055
275 mm	65208.0900.5056
300 mm	65208.0900.5057
515 mm	65208.0900.5058
1175 mm odc.	65208.0900.5059



F maks. = 1000 kN/m



29,2 kg/m



P900/12 RF-AC/30° H250

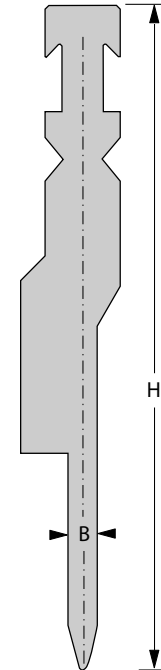

[B] Szerokość (mm)	26,5
[H] Wysokość (mm)	250

Standardowa długość	Numer części
30 mm	65208.0900.5021
35 mm	65208.0900.5022
40 mm	65208.0900.5023
45 mm	65208.0900.5024
50 mm	65208.0900.5025
55 mm	65208.0900.5026
60 mm	65208.0900.5027
65 mm	65208.0900.5028
70 mm	65208.0900.5029
75 mm	65208.0900.5030
80 mm	65208.0900.5031

Standardowa długość	Numer części
85 mm	65208.0900.5032
90 mm	65208.0900.5033
95 mm	65208.0900.5034
100 mm	65208.0900.5035
200 mm	65208.0900.5036
275 mm	65208.0900.5037
300 mm	65208.0900.5001
515 mm	65208.0900.5038
1175 mm odc.	65208.0900.5039



F maks. = 1000 kN/m



34,3 kg/m



Profil płaski V B40

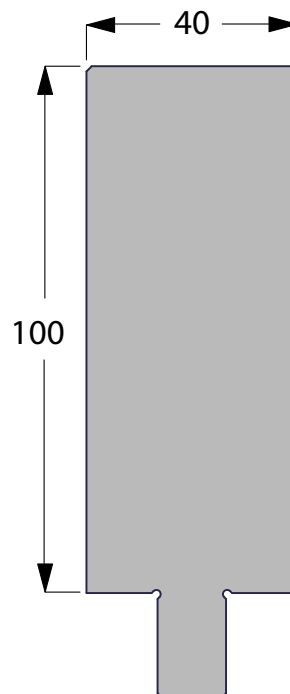

[B] Szerokość (mm)	40
--------------------	----

[H] Wysokość (mm)	100
-------------------	-----

Standardowa długość	Numer części
50 mm	64208.0000.5001
55 mm	64208.0000.5002
60 mm	64208.0000.5003
65 mm	64208.0000.5004
70 mm	64208.0000.5005
75 mm	64208.0000.5006
80 mm	64208.0000.5007
85 mm	64208.0000.5008
90 mm	64208.0000.5009
95 mm	64208.0000.5010
100 mm	64208.0000.5011

Standardowa długość	Numer części
200 mm	64208.0000.5012
275 mm	64208.0000.5013
300 mm	64208.0000.5014
515 mm	64208.0000.5015
1025 mm odc.	64208.0000.5000



F maks. 30° = 2000 kN/m



35,5 kg/m



Wkładka matrycy 13 mm



V900/08C

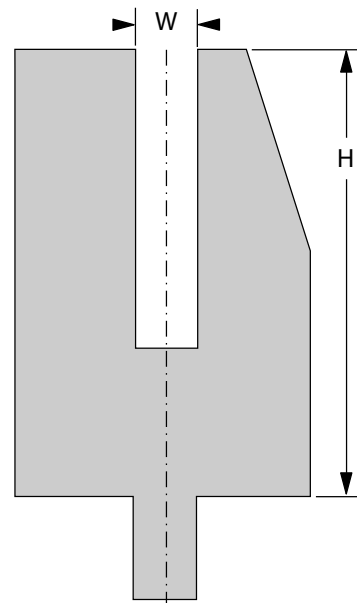

[B] Szerokość (mm) 55

[H] Wysokość (mm) 85

Standardowa długość	Numer części
50 mm	64208.0900.5003
55 mm	64208.0900.5004
60 mm	64208.0900.5005
65 mm	64208.0900.5006
70 mm	64208.0900.5007
75 mm	64208.0900.5008
80 mm	64208.0900.5009
85 mm	64208.0900.5010
90 mm	64208.0900.5011
95 mm	64208.0900.5012
100 mm	64208.0900.5013

Standardowa długość	Numer części
200 mm	64208.0900.5014
275 mm	64208.0900.5015
300 mm	64208.0900.5002
515 mm	64208.0900.5016
1025 mm odc.	64208.0900.5000



F maks. 30° = 250 kN/m



35,5 kg/m



Wkładka matrycy 13 mm



V900/10C

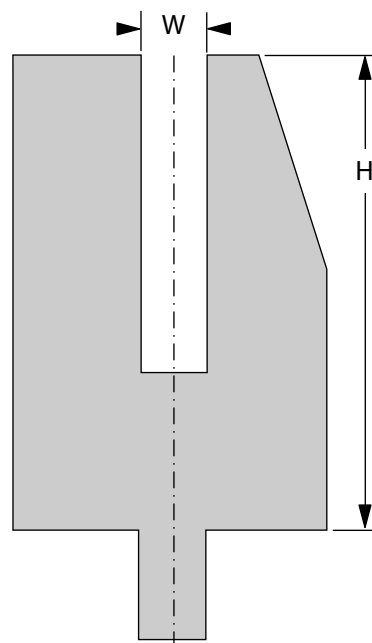

[B] Szerokość (mm) 55

[H] Wysokość (mm) 85

Standardowa długość	Numer części
50 mm	64208.0900.5032
55 mm	64208.0900.5033
60 mm	64208.0900.5034
65 mm	64208.0900.5047
70 mm	64208.0900.5035
75 mm	64208.0900.5036
80 mm	64208.0900.5037
85 mm	64208.0900.5038
90 mm	64208.0900.5039
95 mm	64208.0900.5040
100 mm	64208.0900.5041

Standardowa długość	Numer części
200 mm	64208.0900.5042
275 mm	64208.0900.5043
300 mm	64208.0900.5044
515 mm	64208.0900.5045
1025 mm odc.	64208.0900.5046



F maks. 30° = 250 kN/m



32,0 kg/m



Wkładka matrycy 13 mm



V900/12C

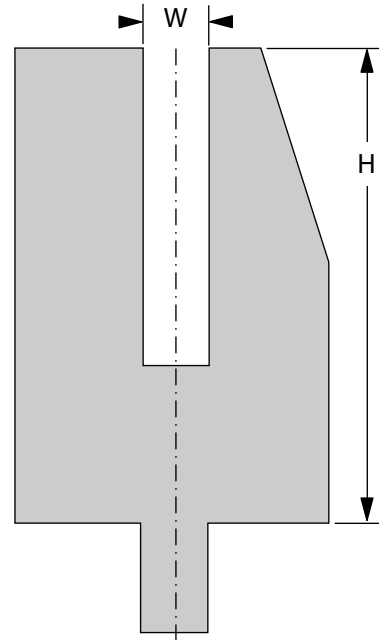

[B] Szerokość (mm)	55
[H] Wysokość (mm)	85

Standardowa długość	Numer części
50 mm	64208.0900.5017
55 mm	64208.0900.5018
60 mm	64208.0900.5019
65 mm	64208.0900.5020
70 mm	64208.0900.5021
75 mm	64208.0900.5022
80 mm	64208.0900.5023
85 mm	64208.0900.5024
90 mm	64208.0900.5025
95 mm	64208.0900.5026
100 mm	64208.0900.5027

Standardowa długość	Numer części
200 mm	64208.0900.5028
275 mm	64208.0900.5029
300 mm	64208.0900.5001
515 mm	64208.0900.5030
1025 mm odc.	64208.0900.5031



F maks. 30° = 250 kN/m



31,0 kg/m



Wkładka matrycy 13 mm



Dane kontaktowe na świecie

Bystronic Laser AG
Industriestrasse 21
3362 Niederönz
Szwajcaria
Tel. +41 62 956 33 33
E-mail info.laser@bystronic.com

Bystronic Australia Pty. Ltd.
4 Latchford Street
Cranbourne West VIC 3977
Australia
Tel.: +61 1300 975 761
E-mail info.au@bystronic.com

Bystronic Austria GmbH
Schärdinger Straße 15
4061 Pasching
Austria
Tel. +43 7229 64411
E-mail office.at@bystronic.com

Bystronic do Brasil Ltda.
Rua Parma 203
83413-587 – Colombo – PR
Brazylia
Tel. +55 41 3666 9000
E-mail bystronic.br@bystronic.com

Bystronic Canada Ltd
3330 Ridgeway Drive, Unit #11
Mississauga, ON L5L 5Z9
Kanada
Tel: +1 905 890 2999
E-mail sales.canada@bystronic.com

Bystronic (Tianjin) Laser Ltd.
No. 46 Xishi Road
Airport Industrial Park
300308 Tianjin
Chiny
Tel: +86 22 5980 1888
E-mail info.tj.cn@bystronic.com

Bystronic Czech Republic s.r.o.
Turanka 115/1222
627 00 Brno Slatina
Czechy
Tel. +420 532 123 314
E-mail info.cz@bystronic.com

Bystronic Ibérica, S.A.
Avda. Tenerife n° 2
Edificio 1, Planta 3, Oficina D
28700 San Sebastián de los Reyes
(Madryt) Hiszpania
Tel. +34 91 654 48 78
E-mail sales.es@bystronic.com

Bystronic France SAS
Parc Technopolis
3, Avenue du Canada
91940 Les Ulis Cedex
Francja
Tel. +33 1 69 41 99 84
E-mail info.fr@bystronic.com

Bystronic Maschinenbau GmbH
Mühlhäuser Strasse 3
99867 Gotha
Niemcy
Tel. +49 3621 38 30
E-mail info.bending@bystronic.com

Bystronic Deutschland GmbH
Römerstrasse 14
71296 Heimsheim
Niemcy
Tel. +49 7033 46 99 0
E-mail info.de@bystronic.com

Bystronic Magyarország Kft.
Budaörs Business Center
Puskás Tivadarút 5
2040 Budaörs
Węgry
Tel: +36 23 610 433
E-mail info.hu@bystronic.com

Bystronic Laser India (Pvt) Ltd.
7C, Tadiwala Road
Next to Hotel Pancharatna
Pune 411 001
Indie
Tel: +91 20 67294800
E-mail info.in@bystronic.com

Bystronic Italia SRL
Via del Lavoro, 30
20813 Bovisio-Masciago
Włochy
Tel. +39 0362 5993 1
E-mail sales.it@bystronic.com

Bystronic Japan, Ltd.
2-95-3 Inadaira Musashimurayama-shi
Tokyo 208-0023
Japonia
Tel: +81 42 506 8271
E-mail Cesar.Mujica@bystronic.com

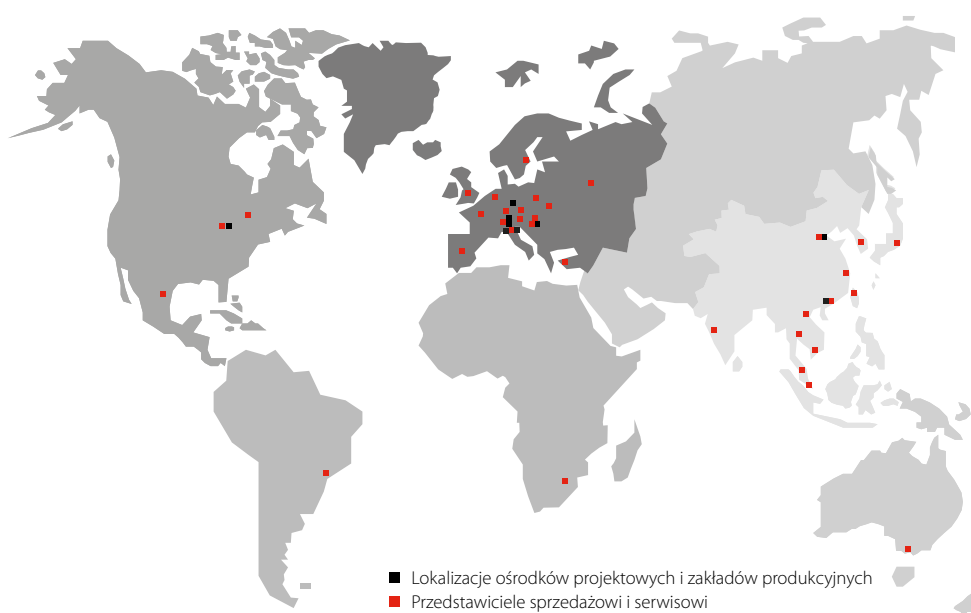



Bystronic Laser Pte. Ltd.

(Representative Office)
Level 8, MCT Tower, Sky Park,
One City, Jalan USJ 25/1
Subang Jaya
47650 Selangor
Malezja
Tel: +60 3 8022 8268

Bystronic Mexico S.A. de C.V.

Helios 401 A, Parque Industrial FINSA
Apodaca
66600 Nuevo León
Meksyk
Tel. +52 81 2133 7600
E-mail sales.mexico@bystronic.com

Bystronic Benelux B.V.

Duurzaamheidsring 11
4231 EX Meerkerk
Holandia
Tel. +31 184 611 020
E-mail sales.benelux@bystronic.com

Bystronic Korea, Ltd.

3F Bystronic Bldg,
32-18, LS-ro
91 Beon-gil, Dongan-gu Anyang-si
14119 Gyeonggi-do
Korea
Tel. +82 31 389 9800
E-mail info.kr@bystronic.com

Bystronic Polska Sp. z o.o.

Ul. Sokołowska 47
PL-05-806 Sokołów
Polska
Tel. +48 22 331 37 70
E-mail info.pl@bystronic.com

S.C. Bystronic Laser S.R.L.

Str. Poienelor no. 5
Industrial Pro Roman Park
500419 Brasov
Rumunia
Tel: +40 268 322 140
E-mail info.ro@bystronic.com

Bystronic Laser

Zorge Street, 9A
Stroenie 2 (Building 2)
125252 Moscow
Rosja
Tel: +7 495 984 71 44
E-mail info.ru@bystronic.com

Bystronic Co., Ltd. (Shanghai)

Room 602, Part A,
No. 388 North Fu Quan Road
Changning District
Shanghai, 200335
Tel. +86 21 6082 9300
E-mail info.sha.cn@bystronic.com

Bystronic Pte. Ltd.

Thye Hong Centre
2 Leng Kee Road #02-04
159086 Singapur
Tel. +65 6472 6300
E-mail info.sg@bystronic.com

Bystronic Scandinavia AB

Metallvägen 30A
195 72 Rosersberg
Szwecja
Tel: +46 (0)8 594 415 50
E-mail Services.SE@bystronic.com

Bystronic Sales AG

Industriestrasse 21
3362 Niederönz
Szwajcaria
Tel. +41 62 956 37 83
E-mail info.sales@bystronic.com

Bystronic International Laser Ltd.

No. 66, Wuquan Rd.,
Wugu Dist.,
New Taipei City 248
Tajwan (R.O.C)
Tel: +886 2 2299 2699
E-mail hotline.tw@bystronic.com

Bystronic Lazer ve Su Isinlari

Makineleri Sanayi ve Ticaret Ltd. Sti.
Serifali Mevkii, Barbaros Caddesi
No: 66 K:1
34775 Ümraniye/Istanbul
Turcja
Tel: +90 216 464 6160
E-mail info.tr@bystronic.com

LLC Bystronic Ukraine

59 Zhylyanskaya Street
Diplomat Hall, 2nd floor, Office 207
1033 Kyiv
Ukraina
Tel. +380 44 569 74 37
E-mail info.cis@bystronic.com

Bystronic UK Ltd.

6 Wayside Business Park
Wilson's Lane
Coventry
Warwickshire CV6 6NY
Wielka Brytania
Tel: +44 (0)844 848 5850
E-mail sales.uk@bystronic.com

Bystronic Inc.

2200 West Central Road
US-Hoffman Estates
IL 60192
USA
Tel. +1 847 214 0300
E-mail sales.us@bystronic.com

Bystronic Vietnam Co. Ltd.

38/7 Truong Chinh Str.
Tan Thoi Nhat Ward
District 12
Hochiminh City
Wietnam
Tel: +84 28 3719 2278
E-mail Anhtuan.Ha@bystronic.com

