

Best choice.
切割.折弯.自动化

Bystronic

Bystronic 模具系列 RF-AC 型模具

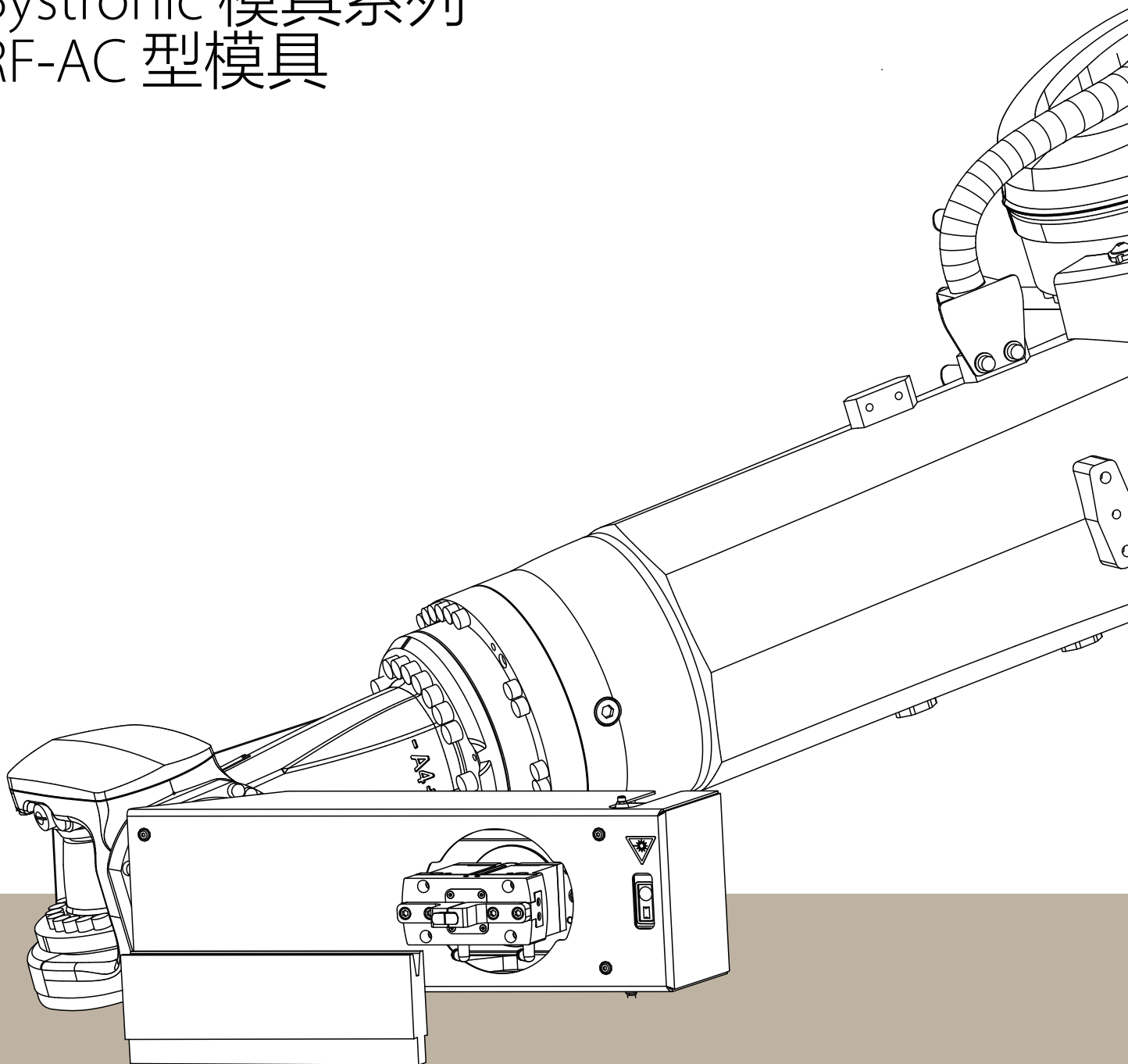



目录

基本信息	3
本产品目录中使用的图标.....	3
自由折弯的计算基本信息.....	4
模具更换是如何实现的?	8
槽口设计	9
分段.....	10
上模	14
上模分段	16
下模	22
下模工作台选项.....	24
下模分段	25
折边模具	60
全球网点联系方式	70



基本信息

本产品目录中使用的图标



硬度：58 - 62 HRC



最大允许载荷



最大腔体深度



重量



可翻转模具

本产品目录涉及以下机型：

Xpert Tool Changer - XTC

Modular Tool Changer - MTC

Bending Cell - BC



自由折弯的计算基本信息

自由折弯的折弯压力对照表

表格中的数据是在折弯长度为 1 m、抗拉强度为 $R_m=420 \text{ N/mm}^2$ 基础上计算的结果。

V	6	8	10	12	16	18	20	24	32	40	50	60	80	
R	1	1.2	1.6	2	2.5	2.8	3	3.5	5	6	8	9.5	12	
t	F 折弯压力 (kN)/折弯长度 1 m													
	a 最小翻边长度 (mm)													
0.5	25													
	4.3													
0.8	70	48												
	4.6	5.7												
1	115	80	60											
	5	6	7											
1.2		120	90	70										
		6	7.5	8.5										
1.5			150	120										
			8	9										
2.0				235	160	135	120	95						
				10	12	13	14.5	17						
2.5					265	225	200	155	110					
					12.5	14	15.5	17.5	23					
3.0							300	240	165	125				
							15.5	17.5	23.5	28				
4.0									315	235	180			
									25	29	35			
5.0									535	430	310	250		
									26	31	35.5	43		
6.0										610	450	360		
										32	36	44		
8.0											880	690	470	
											40	46	57	
10													800	
														60
12														1200
														62
16														
18														
20														

带轧屑的板材会使折弯压力增加 1.05 – 1.1倍



100	120	130	140	150	160	180	190	200	230	260	290	320	V
15.5	19	21	23	24.5	26	28	30	32	36	40	45	50	R
F 折弯压力 (kN)/折弯长度 1 m													t
a 最小翻边长度 (mm)													
													0.5
													0.8
													1
													1.2
													1.5
													2.0
													2.5
													3.0
													4.0
													5.0
													6.0
360													8.0
71													10
600	470	430	390										12
71	85	92	100										16
900	710	650	580	550	500								18
73	86	92	100	105	115								20
	1400	1250	1150	1050	950	810	800	710	600				
	90	98	105	110	115	130	135	140	160				
			1480	1350	1250	1100	1000	950	800	700	600		
			105	110	120	130	135	140	160	180	205		
						1400	1300	1200	1000	900	850	700	
						135	140	145	165	180	205	225	

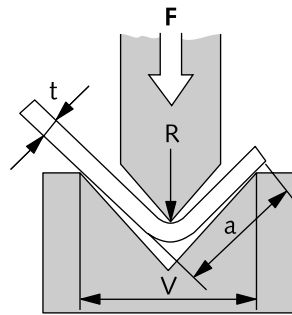

内径 R 约等于凹模开口宽度 V 的 16%。



自由折弯的计算基本信息

计算公式

自由折弯的推荐下模开口宽度 V

材料厚度	t	0.5–2.5 mm	3–8 mm	9–10 mm	> 12 mm
下模开口宽度	V	6 × t	8 × t	10 × t	12 × t

折弯压力

铝	Rm = 300 N/mm ²	F = F (表格) × 0.65
碳钢	Rm = 420 N/mm ²	F = F (表格)
不锈钢	Rm = 700 N/mm ²	F = F (表格) × 1.6

自由折弯的折弯压力计算公式 (参考值)

$$F = \frac{Rm \times t^2}{V} \times \left(1 + \frac{4 \times t}{V}\right)$$

换算: Rm = 抗拉强度 (N/mm²)

10 N = 1 Kg

10 kN = 1 t

最小内径 R 换算表

厚度t	1	2	3	4	5	6	8	10	12	16	18	20
最小内径R	1	2	3	5	6	8	12	16	20	28	36	40



抗拉强度

材料		抗拉强度	
美标	欧标	KPSI	N/mm ²
6061 铝合金	Alu 50	42	290
5052 铝合金	Alu 35	44	303
1010 低碳钢	DC01	53	366
A536-80 G 60-40-18	GGG-40	58	400
A 351 G CF 8	G-X 6CrNi 18 9	65	450
A 572 G50	S 355 MC	80	550
Domex 80	S 420 MC	80	550
A 36	S 235 JR	80	552
304 不锈钢	Inox V2A	85	586
316 不锈钢	Inox V4A	87	600
A 572 G 65	S 460 MC	95	655
Domex 100	S 500 MC	102	700
Domex 550	S 550 MC	110	760
Domex 600	S 600 MC	119	820
Weldox 700	Weldox 700	123	850
Domex 650	S 650 MC	128	880
Domex 700	S 700 MC	138	950
4140 低合金钢	42 CrMo 4	145	1000
Weldox 900	Weldox 900	149	1030
Weldox 960	Weldox 960	154	1060
Hardox 400	Hardox 400	181	1250
Hardox 500	Hardox 500	225	1550

请咨询高强度材料折弯专业顾问。



模具更换是如何实现的？

智能自动化设备，快速精准更换模具

- 支持自动更换上/下模，显著节省时间并提升折弯质量
- 即使使用大型模具 (BC 最大可处理 V80 模具；MTC 最大可处理 V120 模具)，也能在上/下工作台的夹紧系统中精准无误地定位模具套件
- 随时便捷扩展模具：智能传感器技术自动检测新模具，并将其添加到模具库中
- 上模可自动旋转，满足更多样化的折弯应用需求
- 所有模具都在机器内部准备就绪，符合人体工学设计，操作简便
- 支持自动清洁折弯工作台，确保精细加工折弯工件



* 模具最大重量：

Gripper XTC	- 最大重量：15.0 kg
Gripper BC/MTC	- 最大重量：25.0 kg



槽口设计

上模

上模背面带有槽口。非对称结构的冲头 (例如 P4 和 P5) 的正面也带有槽口。
可以处理高度 250 mm 的 P2、P3、P4、P5、P6、P7、P8、P9、P11 和 P900 型冲头。按需提供高度 350 mm 高度的模具。
最小分段长度为 30 mm，最大分段长度为 515 mm*。

下模

下模背面带有槽口。因此可以通过机械手搬运模具。
与 V6 到 V120 的凹模镶件搭配使用**。
最小分段长度为 50 mm，最大分段长度为 515 mm*。



* 515 mm 分段长度按需提供，或者在 BC/MTC 上标配提供

** XTC 最大可处理 V80 凹模镶件
BC/MTC 最大可处理 V120 凹模镶件



分段

适用 Xpert Tool Changer、MTC 和 BC

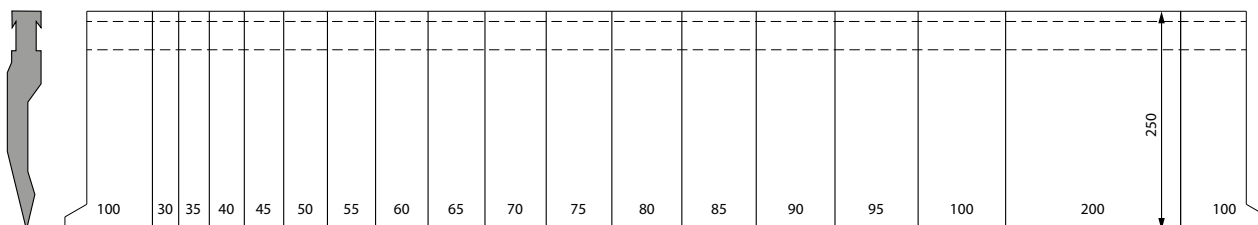

上模	零件号
冲头 P2 RF-AC/85° H=250 L=1375 sect.	65208.0002.5000
冲头 P4 RF-AC/85° H=250 L=1375 sect.	65208.0004.5000
冲头 P5 RF-AC/30° H=250 L=1375 sect.	65208.0005.5000
冲头 P7 RF-AC/30° H=250 L=1375 sect.	65208.0007.5000

所有可选分段长度如下：

30 mm、35 mm、40 mm、45 mm、50 mm、55 mm、60 mm、65 mm、70 mm、75 mm、80 mm、85 mm、90 mm、95 mm、100 mm、200 mm、砧座套件 100 mm (左侧+右侧)

上模	零件号
冲头 P11 RF-AC B=20 H=250 L=1175 sect.	65208.0011.5000

可选分段长度如下：

30 mm、35 mm、40 mm、45 mm、50 mm、55 mm、60 mm、65 mm、70 mm、75 mm、80 mm、85 mm、90 mm、95 mm、100 mm、200 mm

下模	零件号
凹模镶件 V-Flat B40 L=1025 sect.	65208.0000.5000

可选分段长度如下：

50 mm、55 mm、60 mm、65 mm、70 mm、75 mm、80 mm、85 mm、90 mm、95 mm、100 mm、200 mm

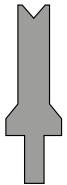

50	55	60	65	70	75	80	85	90	95	100	200

下模		零件号
凹模镶件 V6C/30°	L=1025 sect.	64208.0006.5000
凹模镶件 V8C/30°	L=1025 sect.	64208.0008.5000
凹模镶件 V10C/30°	L=1025 sect.	64208.0010.5000
凹模镶件 V12C/30°	L=1025 sect.	64208.0012.5000
凹模镶件 V16C/30°	L=1025 sect.	64208.0020.5000
凹模镶件 V20C/30°	L=1025 sect.	64208.0020.5000
凹模镶件 V24C/30°	L=1025 sect.	64208.0024.5000
凹模镶件 V32C/30°	L=1025 sect.	64208.0032.5000
凹模镶件 V40C/60°	L=1025 sect.	64208.0040.5000
凹模镶件 V50C/60°	L=1025 sect.	64208.0050.5000
凹模镶件 V60C/60°	L=1025 sect.	64208.0060.5000
凹模镶件 V80C/80°	L=1025 sect.	64208.0080.5000
凹模镶件 V100C/80°	L=1025 sect.	64208.0100.5000
凹模镶件 V120C/80°	L=1025 sect.	64208.0120.5000
凹模镶件 V6SC/30°	L=1025 sect.	64208.0006.5100
凹模镶件 V8SC/30°	L=1025 sect.	64208.0008.5100
凹模镶件 V10SC/30°	L=1025 sect.	64208.0010.5100
凹模镶件 V12SC/30°	L=1025 sect.	64208.0012.5100

所有可选分段长度如下:

50 mm、55 mm、60 mm、65 mm、70 mm、75 mm、80 mm、85 mm、90 mm、95 mm、100 mm、200 mm

*** XTC 最大可处理 V80 下模**
BC/MTC 最大可处理 V120 下模



分段

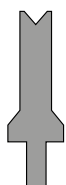

50	55	60	65	70	75	80	85	90	95	100	200

下模	零件号
凹模镶件 V6C/30° H=100 L=1025 sect.	64208.0006.5031
凹模镶件 V8C/30° H=100 L=1025 sect.	64208.0008.5165
凹模镶件 V10C/30° H=100 L=1025 sect.	64208.0010.5031
凹模镶件 V12C/30° H=100 L=1025 sect.	64208.0012.5030
凹模镶件 V16C/30° H=100 L=1025 sect.	64208.0020.5040
凹模镶件 V20C/30° H=100 L=1025 sect.	64208.0020.5030
凹模镶件 V24C/30° H=100 L=1025 sect.	64208.0024.5031
凹模镶件 V32C/30° H=100 L=1025 sect.	64208.0032.5030
凹模镶件 V40C/60° H=100 L=1025 sect.	64208.0040.5030
凹模镶件 V50C/60° H=100 L=1025 sect.	64208.0050.5030
凹模镶件 V60C/60° H=100 L=1025 sect.	64208.0060.5030
凹模镶件 V80C/80° H=100 L=1025 sect.	64208.0080.5030

所有可选分段长度如下：

50 mm、55 mm、60 mm、65 mm、70 mm、75 mm、80 mm、85 mm、90 mm、
95 mm、100 mm、200 mm

*** XTC 最大可处理 V80 下模**
BC/MTC 最大可处理 V120 下模

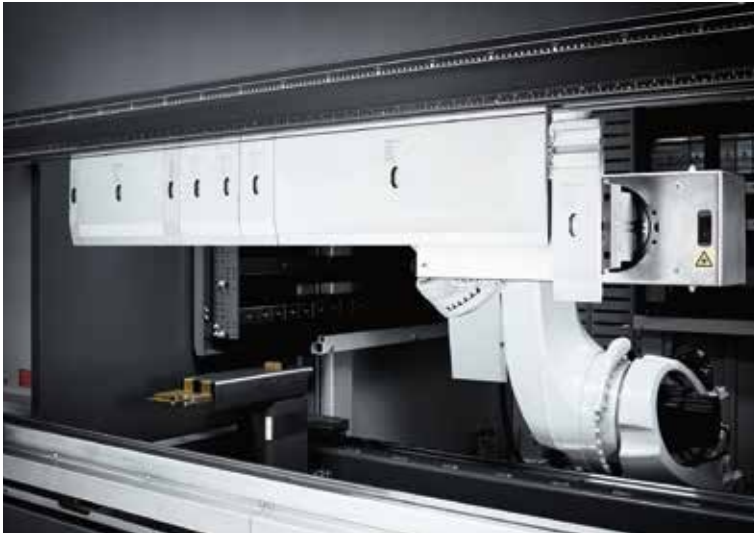



上模

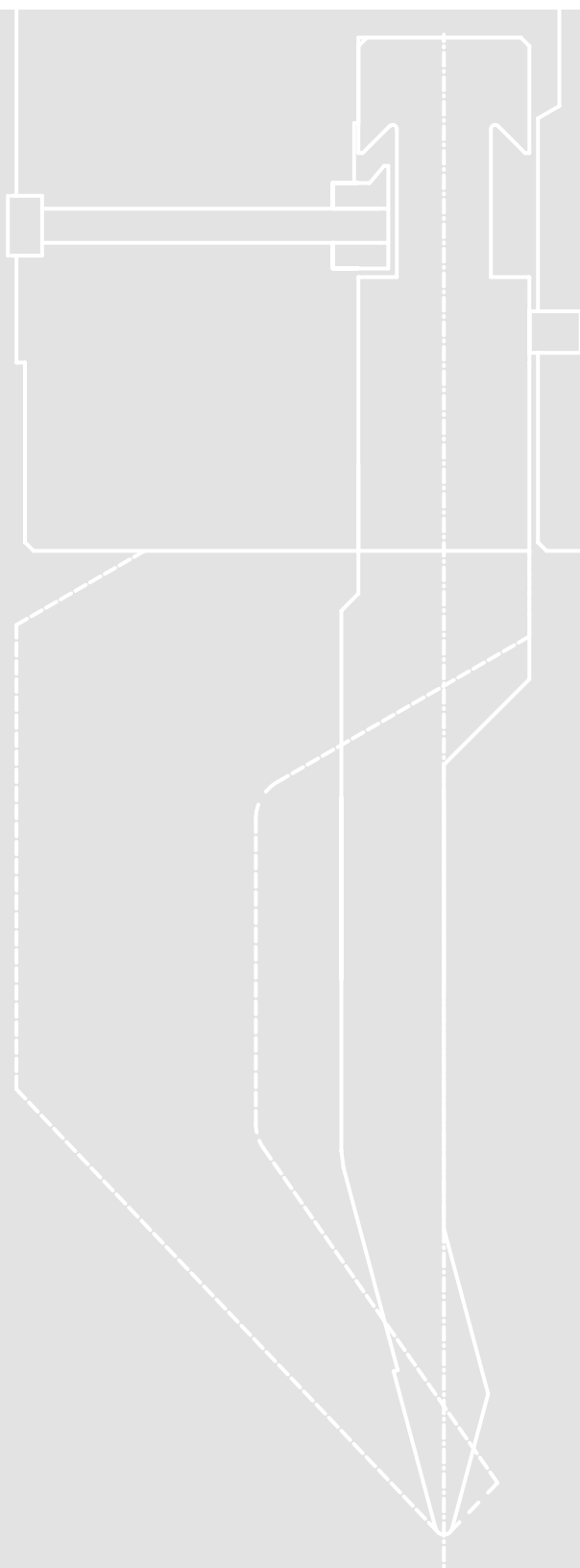





上模分段

砧座 RF-AC

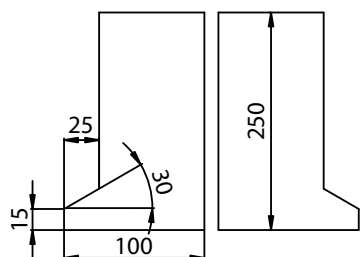

冲头 RF-AC L = 1375 sect.

(30+35+40+45+50+60+65+70+75+80+85+90+95+100+200+砧座 (左侧+右侧))

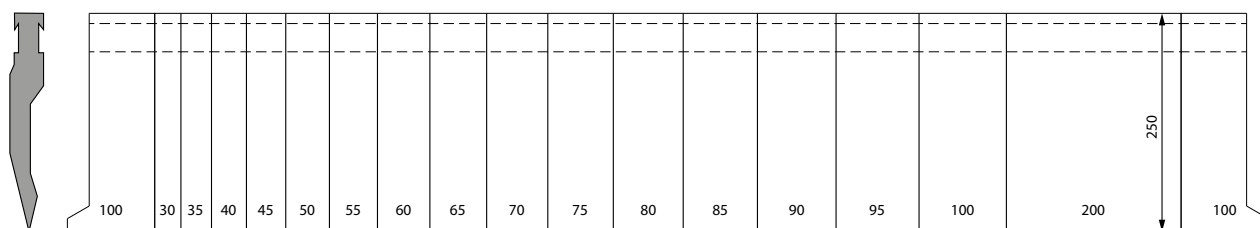

按需提供特殊分段。

按需提供其他半径规格的所有上模。

模具最大重量：

Gripper XTC - 最大重量：15.0 kg

Gripper BC/MTC - 最大重量：25.0 kg



Modular Tool Changer



Bending Cell





P2 RF-AC/85° H250

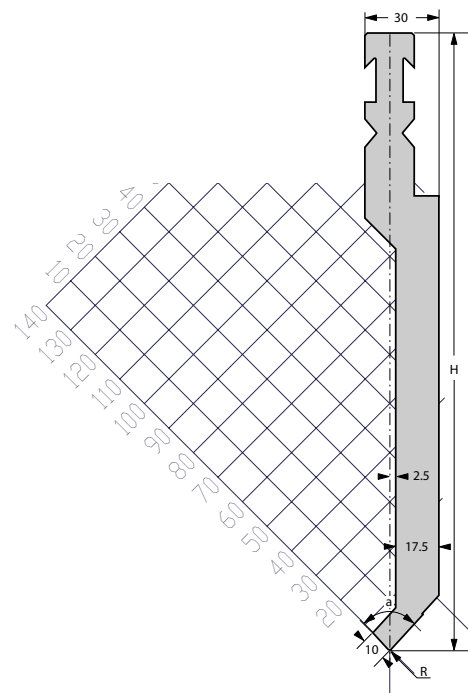

[R] 半径 (mm)*	1.0
尖端角度	85°
[H] 高度	250

*按需提供其他半径规格

标准长度	零件号
30 mm	65208.0002.5001
35 mm	65208.0002.5002
40 mm	65208.0002.5003
45 mm	65208.0002.5004
50 mm	65208.0002.5005
55 mm	65208.0002.5006
60 mm	65208.0002.5007
65 mm	65208.0002.5008
70 mm	65208.0002.5015
75 mm	65208.0002.5016
80 mm	65208.0002.5017

标准长度	零件号
85 mm	65208.0002.5018
90 mm	65208.0002.5019
95 mm	65208.0002.5020
100 mm	65208.0002.5011
200 mm	65208.0002.5012
275 mm	65208.0002.5013
300 mm	65208.0002.5014
515 mm	65208.0002.5019
沾座套件 (左侧+右侧)	65208.0002.7001
沾座 (左侧)	65208.0002.7002
沾座 (右侧)	65208.0002.7003



F max = 1000 kN/m



34.4 kg/m



98.0 mm



P4 RF-AC/85° H250

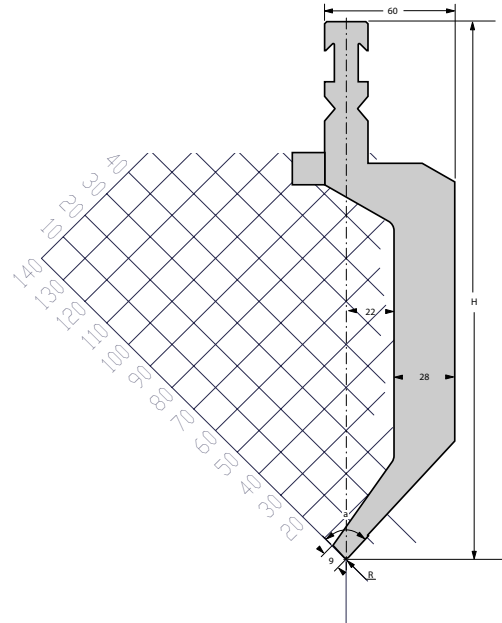

[R] 半径 (mm)*	1.5
尖端角度	85°
[H] 高度	250

*按需提供其他半径规格

标准长度	零件号
30 mm	65208.0004.5001
35 mm	65208.0004.5002
40 mm	65208.0004.5003
45 mm	65208.0004.5004
50 mm	65208.0004.5005
55 mm	65208.0004.5006
60 mm	65208.0004.5007
65 mm	65208.0004.5008
70 mm	65208.0004.5015
75 mm	65208.0004.5016
80 mm	65208.0004.5017

标准长度	零件号
85 mm	65208.0004.5018
90 mm	65208.0004.5019
95 mm	65208.0004.5020
100 mm	65208.0004.5011
200 mm	65208.0004.5012
275 mm	65208.0004.5013
300 mm	65208.0004.5014
沾座套件 (左侧+右侧)	65208.0004.7003
沾座 (左侧)	65208.0004.7001
沾座 (右侧)	65208.0004.7002



F max = 600 kN/m



48.3 kg/m



98.0 mm



P5 RF-AC/30° H250

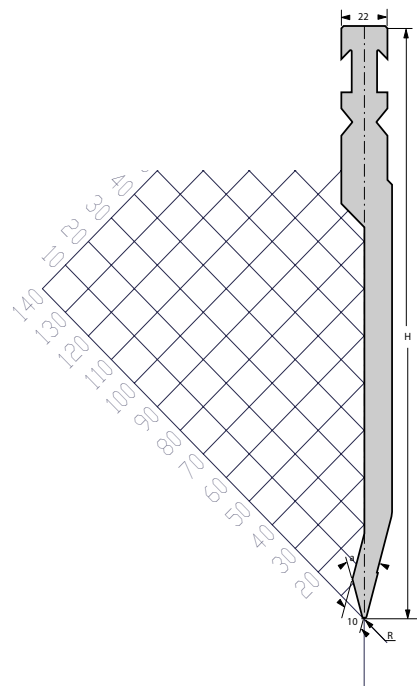

[R] 半径 (mm)*	1
尖端角度	30°
[H] 高度	250

*按需提供其他半径规格

标准长度	零件号
30 mm	65208.0005.5001
35 mm	65208.0005.5002
40 mm	65208.0005.5003
45 mm	65208.0005.5004
50 mm	65208.0005.5005
55 mm	65208.0005.5006
60 mm	65208.0005.5007
65 mm	65208.0005.5008
70 mm	65208.0005.5015
75 mm	65208.0005.5016
80 mm	65208.0005.5017

标准长度	零件号
85 mm	65208.0005.5018
90 mm	65208.0005.5019
95 mm	65208.0005.5020
100 mm	65208.0005.5011
200 mm	65208.0005.5012
275 mm	65208.0005.5013
300 mm	65208.0005.5014
515 mm	65208.0005.5021
沾座套件 (左侧+右侧)	65208.0005.7003
沾座 (左侧)	65208.0005.7001
沾座 (右侧)	65208.0005.7002



F max = 750 kN/m



26.0 kg/m



98.0 mm



P7 RF-AC/30° H250

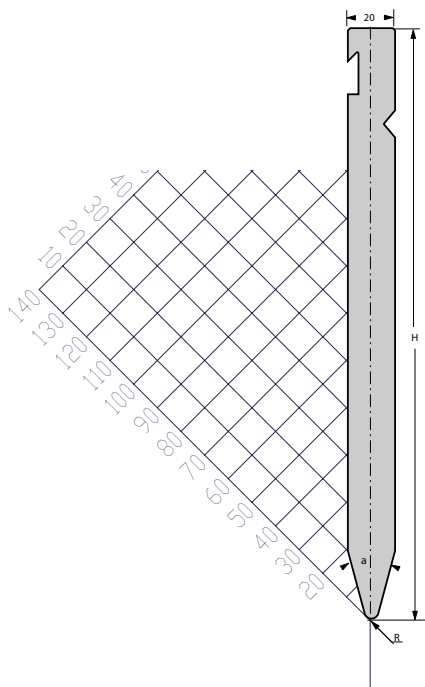

[R] 半径 (mm)*	3
尖端角度	30°
[H] 高度	250

*按需提供其他半径规格

标准长度	零件号
30 mm	65208.0007.5001
35 mm	65208.0007.5002
40 mm	65208.0007.5003
45 mm	65208.0007.5004
50 mm	65208.0007.5005
55 mm	65208.0007.5006
60 mm	65208.0007.5007
65 mm	65208.0007.5008
70 mm	65208.0007.5015
75 mm	65208.0007.5016
80 mm	65208.0007.5017

标准长度	零件号
85 mm	65208.0007.5018
90 mm	65208.0007.5019
95 mm	65208.0007.5020
100 mm	65208.0007.5011
200 mm	65208.0007.5012
275 mm	65208.0007.5013
300 mm	65208.0007.5014
515 mm	65208.0007.5026
站座套件 (左侧+右侧)	65208.0007.7003
站座 (左侧)	65208.0007.7001
站座 (右侧)	65208.0007.7002



F max = 1400 kN/m



35.9 kg/m



98.0 mm



下模

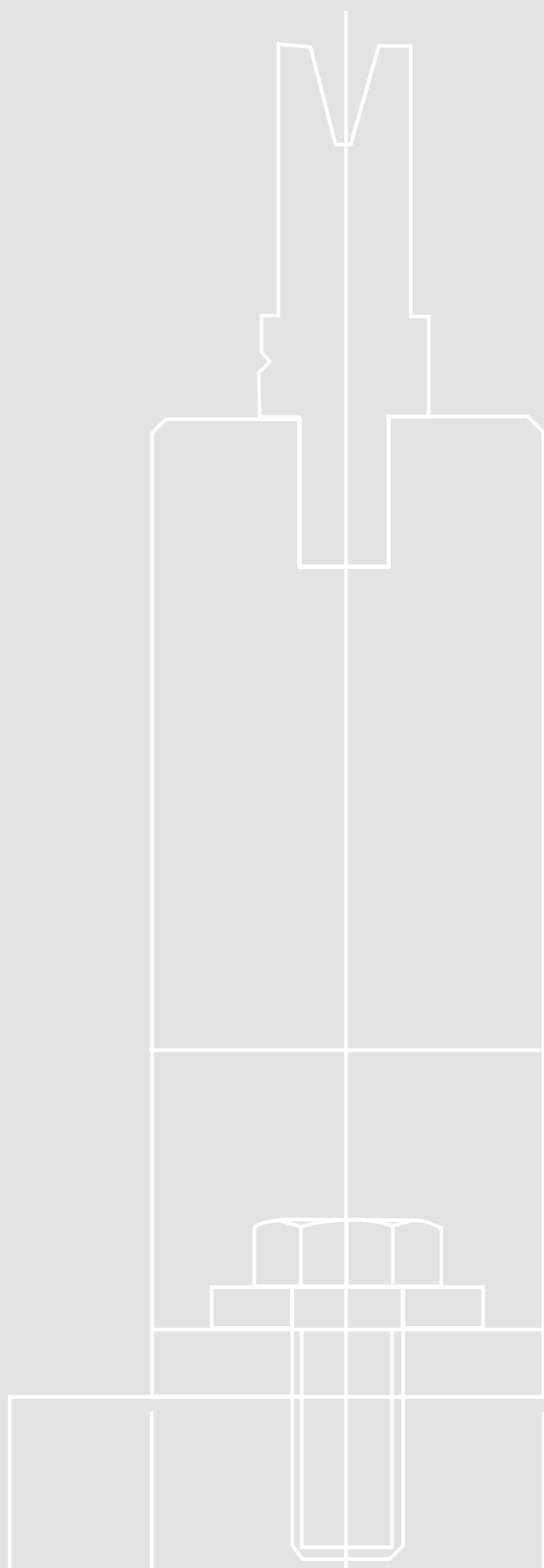





下模工作台选项

带液压模具夹紧块的工作台

T12

(可选 Xpert 60 - 320 和
Xpert 250 - 1000)

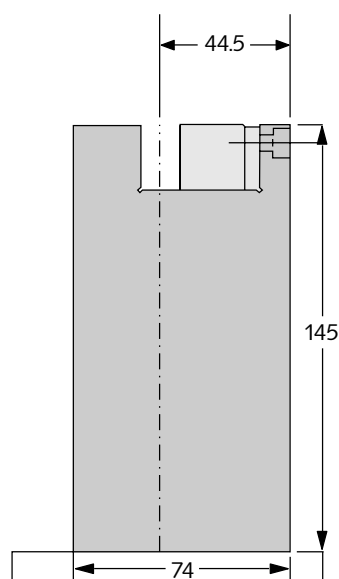

T13

(可选 Xpert 60 - 320 和
Xpert 250 - 1000)

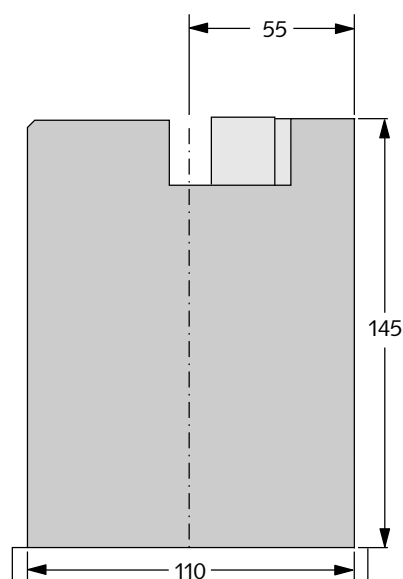



下模分段

凹模镶件 VC L = 1025 sect.



50	55	60	65	70	75	80	85	90	95	100	200

按需提供特殊分段。

此外，支持自定义所有下模半径、模角和高度 (非标参数)。



V6C/30° H55

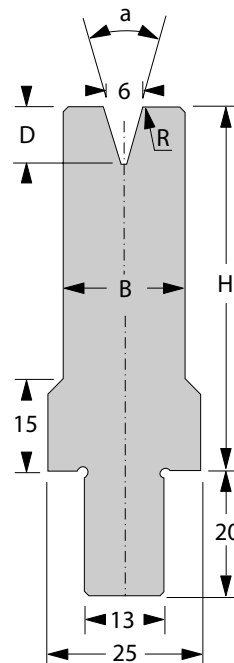

[R] 半径 (mm)* 0.75

[a] V - 角度 30°

[H] 高度 55

[B] 宽度 20

[D] 深度 9.3

*按需提供其他半径规格

标准长度	零件号
50 mm	64208.0006.5001
55 mm	64208.0006.5002
60 mm	64208.0006.5003
65 mm	64208.0006.5004
70 mm	64208.0006.5005
75 mm	64208.0006.5006
80 mm	64208.0006.5007
85 mm	64208.0006.5008
90 mm	64208.0006.5009
95 mm	64208.0006.5010
100 mm	64208.0006.5011

标准长度	零件号
200 mm	64208.0006.5012
275 mm	64208.0006.5013
300 mm	64208.0006.5014
515 mm	64208.0006.5015
1025 mm sect.	64208.0006.5000



F max 30° = 400 kN/m



10.9 kg/m



凹模镶件 13 mm



V6C/30° H100

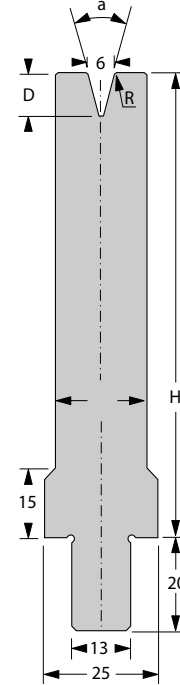

[R] 半径 (mm)*	0.75
[a] V - 角度	30°
[H] 高度	100

[B] 宽度	20
[D] 深度	9.3

*按需提供其他半径规格

标准长度	零件号
50 mm	64208.0006.5016
55 mm	64208.0006.5017
60 mm	64208.0006.5018
65 mm	64208.0006.5019
70 mm	64208.0006.5020
75 mm	64208.0006.5021
80 mm	64208.0006.5022
85 mm	64208.0006.5023
90 mm	64208.0006.5024
95 mm	64208.0006.5025
100 mm	64208.0006.5026

标准长度	零件号
200 mm	64208.0006.5027
275 mm	64208.0006.5028
300 mm	64208.0006.5029
515 mm	64208.0006.5030
1025 mm sect.	64208.0006.5031



F max 30° = 400 kN/m



18.0 kg/m



凹模镶件 13 mm



V8C/30° H55

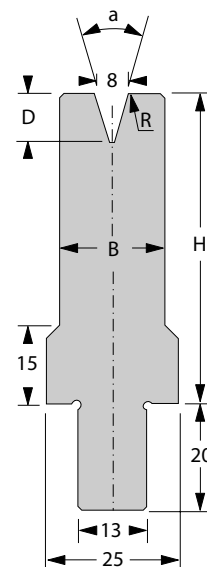

[R] 半径 (mm)*	1
[a] V - 角度	30°
[H] 高度	55

[B] 宽度	20
[D] 深度	11.2

*按需提供其他半径规格

标准长度	零件号
50 mm	64208.0008.5001
55 mm	64208.0008.5002
60 mm	64208.0008.5003
65 mm	64208.0008.5004
70 mm	64208.0008.5005
75 mm	64208.0008.5006
80 mm	64208.0008.5007
85 mm	64208.0008.5008
90 mm	64208.0008.5009
95 mm	64208.0008.5010
100 mm	64208.0008.5011

标准长度	零件号
200 mm	64208.0008.5012
275 mm	64208.0008.5013
300 mm	64208.0008.5014
515 mm	64208.0008.5015
1025 mm sect.	64208.0008.5000



F max 30° = 400 kN/m



10.8 kg/m



凹模镶件 13 mm



V8C/30° H100

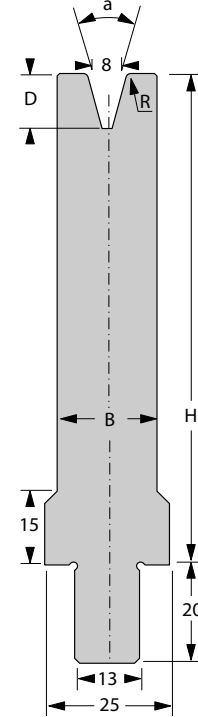

[R] 半径 (mm)*	1
[a] V - 角度	30°
[H] 高度	100

[B] 宽度	20
[D] 深度	11.2

*按需提供其他半径规格

标准长度	零件号
50 mm	64208.0008.5016
55 mm	64208.0008.5017
60 mm	64208.0008.5018
65 mm	64208.0008.5019
70 mm	64208.0008.5020
75 mm	64208.0008.5021
80 mm	64208.0008.5022
85 mm	64208.0008.5023
90 mm	64208.0008.5024
95 mm	64208.0008.5025
100 mm	64208.0008.5026

标准长度	零件号
200 mm	64208.0008.5027
275 mm	64208.0008.5028
300 mm	64208.0008.5029
515 mm	64208.0008.5030
1025 mm sect.	64208.0008.5165



$F_{max} 30^\circ = 300 \text{ kN/m}$



17.8 kg/m



凹模镶件 13 mm



V10C/30° H55

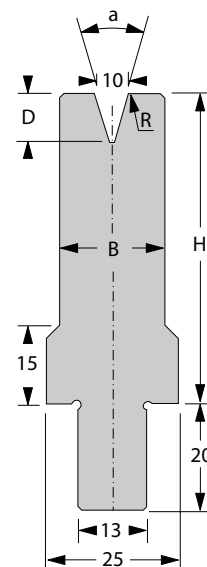
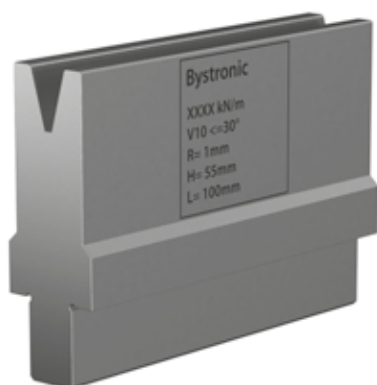

[R] 半径 (mm)*	1
[a] V - 角度	30°
[H] 高度	55

[B] 宽度	20
[D] 深度	14.9

*按需提供其他半径规格

标准长度	零件号
50 mm	64208.0010.5001
55 mm	64208.0010.5002
60 mm	64208.0010.5003
65 mm	64208.0010.5004
70 mm	64208.0010.5005
75 mm	64208.0010.5006
80 mm	64208.0010.5007
85 mm	64208.0010.5008
90 mm	64208.0010.5009
95 mm	64208.0010.5010
100 mm	64208.0010.5011
200 mm	64208.0010.5012

标准长度	零件号
275 mm	64208.0010.5013
300 mm	64208.0010.5014
515 mm	64208.0010.5015
1025 mm sect.	64208.0010.5000



F max 30° = 200 kN/m



10.6 kg/m



凹模镶件 13 mm



V10C/30° H100

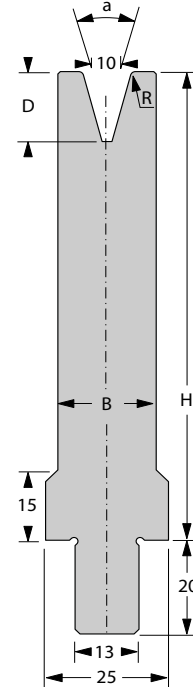

[R] 半径 (mm)*	1
[a] V - 角度	30°
[H] 高度	100

[B] 宽度	20
[D] 深度	14.9

*按需提供其他半径规格

标准长度	零件号
50 mm	64208.0010.5016
55 mm	64208.0010.5017
60 mm	64208.0010.5018
65 mm	64208.0010.5019
70 mm	64208.0010.5020
75 mm	64208.0010.5021
80 mm	64208.0010.5022
85 mm	64208.0010.5023
90 mm	64208.0010.5024
95 mm	64208.0010.5025
100 mm	64208.0010.5026

标准长度	零件号
200 mm	64208.0010.5027
275 mm	64208.0010.5028
300 mm	64208.0010.5029
515 mm	64208.0010.5030
1025 mm sect.	64208.0010.5031



$F_{max} 30^\circ = 200 \text{ kN/m}$



17.6 kg/m



凹模镶件 13 mm



V12C/30° H55

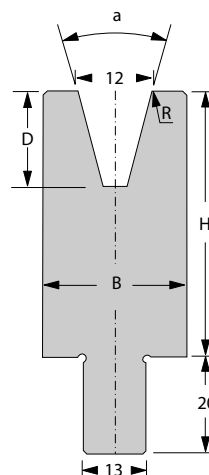

[R] 半径 (mm)*	1.5
[a] V - 角度	30°
[H] 高度	55

[B] 宽度	25
[D] 深度	18.6

*按需提供其他半径规格

标准长度	零件号
50 mm	64208.0012.5001
55 mm	64208.0012.5002
60 mm	64208.0012.5003
65 mm	64208.0012.5004
70 mm	64208.0012.5005
75 mm	64208.0012.5006
80 mm	64208.0012.5007
85 mm	64208.0012.5008
90 mm	64208.0012.5009
95 mm	64208.0012.5010
100 mm	64208.0012.5011

标准长度	零件号
200 mm	64208.0012.5012
275 mm	64208.0012.5013
300 mm	64208.0012.5014
515 mm	64208.0012.5015
1025 mm sect.	64208.0012.5000



F max 30° = 250 kN/m



11.8 kg/m



凹模镶件 13 mm



V12C/30° H100

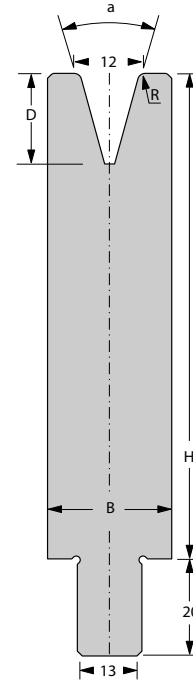

[R] 半径 (mm)*	1.5
[a] V - 角度	30°
[H] 高度	100

[B] 宽度	25
[D] 深度	18.6

*按需提供其他半径规格

标准长度	零件号
50 mm	64208.0012.5017
55 mm	64208.0012.5018
60 mm	64208.0012.5019
65 mm	64208.0012.5020
70 mm	64208.0012.5021
75 mm	64208.0012.5022
80 mm	64208.0012.5023
85 mm	64208.0012.5024
90 mm	64208.0012.5025
95 mm	64208.0012.5026
100 mm	64208.0012.5027

标准长度	零件号
200 mm	64208.0012.5028
275 mm	64208.0012.5029
300 mm	64208.0012.5016
515 mm	64208.0012.5031
1025 mm sect.	64208.0012.5030



$F_{max} 30^\circ = 250 \text{ kN/m}$



20.6 kg/m



凹模镶件 13 mm



V16C/30° H55

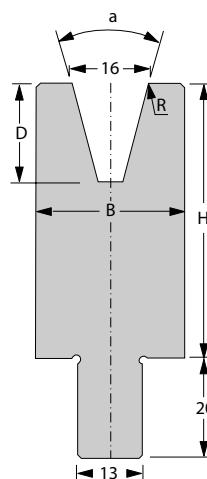

[R] 半径 (mm)*	2
[a] V - 角度	30°
[H] 高度	55

[B] 宽度	30
[D] 深度	20.5

*按需提供其他半径规格

标准长度	零件号
50 mm	64208.0016.5001
55 mm	64208.0016.5002
60 mm	64208.0016.5003
65 mm	64208.0016.5004
70 mm	64208.0016.5005
75 mm	64208.0016.5006
80 mm	64208.0016.5007
85 mm	64208.0016.5008
90 mm	64208.0016.5009
95 mm	64208.0016.5010
100 mm	64208.0016.5011

标准长度	零件号
200 mm	64208.0016.5012
275 mm	64208.0016.5013
300 mm	64208.0016.5014
515 mm	64208.0016.5015
1025 mm sect.	64208.0016.5000



F max 30° = 250 kN/m



13.3 kg/m



凹模镶件 13 mm



V16C/30° H100

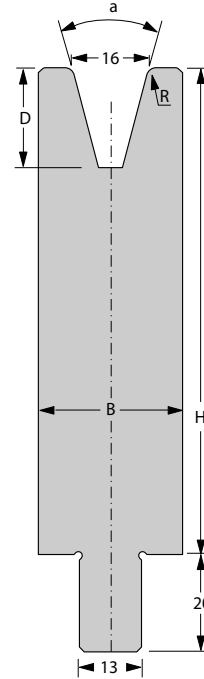

[R] 半径 (mm)*	2
[a] V - 角度	30°
[H] 高度	100

[B] 宽度	30
[D] 深度	20.5

*按需提供其他半径规格

标准长度	零件号
50 mm	64208.0016.5016
55 mm	64208.0016.5017
60 mm	64208.0016.5018
65 mm	64208.0016.5019
70 mm	64208.0016.5020
75 mm	64208.0016.5021
80 mm	64208.0016.5022
85 mm	64208.0016.5023
90 mm	64208.0016.5024
95 mm	64208.0016.5025
100 mm	64208.0016.5026

标准长度	零件号
200 mm	64208.0016.5027
275 mm	64208.0016.5028
300 mm	64208.0016.5029
515 mm	64208.0016.5030
1025 mm sect.	64208.0016.5040



F max 30° = 250 kN/m



23.9 kg/m



凹模镶件 13 mm



V20C/30° H55

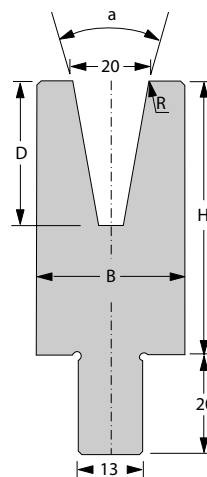

[R] 半径 (mm)*	2.5
[a] V - 角度	30°
[H] 高度	55

[B] 宽度	30
[D] 深度	28

*按需提供其他半径规格

标准长度	零件号
50 mm	64208.0020.5001
55 mm	64208.0020.5002
60 mm	64208.0020.5003
65 mm	64208.0020.5004
70 mm	64208.0020.5005
75 mm	64208.0020.5006
80 mm	64208.0020.5007
85 mm	64208.0020.5008
90 mm	64208.0020.5009
95 mm	64208.0020.5010
100 mm	64208.0020.5011

标准长度	零件号
200 mm	64208.0020.5012
275 mm	64208.0020.5013
300 mm	64208.0020.5014
515 mm	64208.0020.5015
1025 mm sect.	64208.0020.5000



F max 30° = 150 kN/m



12.2 kg/m



凹模镶件 13 mm



V20C/30° H100

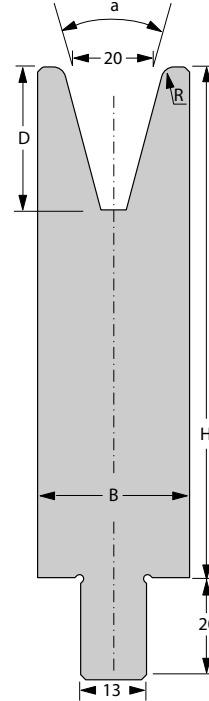

[R] 半径 (mm)*	2.5
[a] V - 角度	30°
[H] 高度	100

[B] 宽度	30
[D] 深度	28

*按需提供其他半径规格

标准长度	零件号
50 mm	64208.0020.5017
55 mm	64208.0020.5018
60 mm	64208.0020.5019
65 mm	64208.0020.5020
70 mm	64208.0020.5021
75 mm	64208.0020.5022
80 mm	64208.0020.5023
85 mm	64208.0020.5024
90 mm	64208.0020.5025
95 mm	64208.0020.5026
100 mm	64208.0020.5027

标准长度	零件号
200 mm	64208.0020.5028
275 mm	64208.0020.5029
300 mm	64208.0020.5016
515 mm	64208.0020.5031
1025 mm sect.	64208.0020.5030



$F_{max} 30^\circ = 150 \text{ kN/m}$



22.8 kg/m



凹模镶件 13 mm



V24C/30° H55

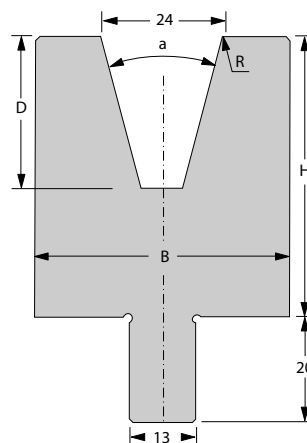

[R] 半径 (mm)*	3
[a] V - 角度	30°
[H] 高度	55

[B] 宽度	40
[D] 深度	29.8

*按需提供其他半径规格

标准长度	零件号
50 mm	64208.0024.5001
55 mm	64208.0024.5002
60 mm	64208.0024.5003
65 mm	64208.0024.5004
70 mm	64208.0024.5005
75 mm	64208.0024.5006
80 mm	64208.0024.5007
85 mm	64208.0024.5008
90 mm	64208.0024.5009
95 mm	64208.0024.5010
100 mm	64208.0024.5011

标准长度	零件号
200 mm	64208.0024.5012
275 mm	64208.0024.5013
300 mm	64208.0024.5014
515 mm	64208.0024.5015
1025 mm sect.	64208.0024.5000



F max 30° = 300 kN/m



15.5 kg/m



凹模镶件 13 mm



V24C/30° H100

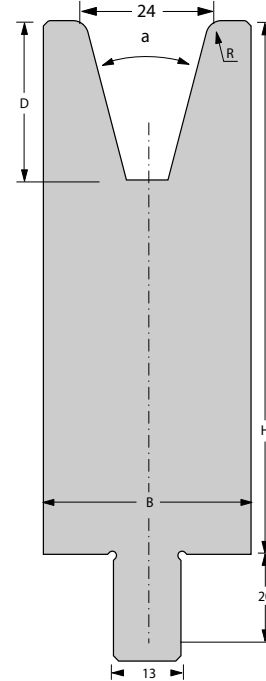

[R] 半径 (mm)*	3
[a] V - 角度	30°
[H] 高度	100

[B] 宽度	40
[D] 深度	29.8

*按需提供其他半径规格

标准长度	零件号
50 mm	64208.0024.5016
55 mm	64208.0024.5017
60 mm	64208.0024.5018
65 mm	64208.0024.5019
70 mm	64208.0024.5020
75 mm	64208.0024.5021
80 mm	64208.0024.5022
85 mm	64208.0024.5023
90 mm	64208.0024.5024
95 mm	64208.0024.5025
100 mm	64208.0024.5026

标准长度	零件号
200 mm	64208.0024.5027
275 mm	64208.0024.5028
300 mm	64208.0024.5029
515 mm	64208.0024.5030
1025 mm sect.	64208.0024.5031



$F_{max} 30^\circ = 300 \text{ kN/m}$



29.6 kg/m



凹模镶件 13 mm



V32C/30° H55

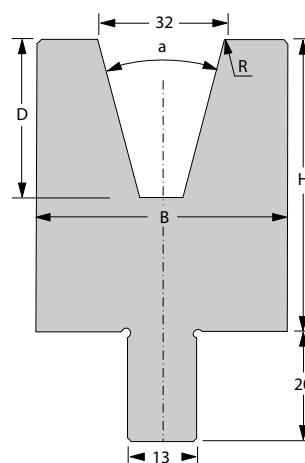
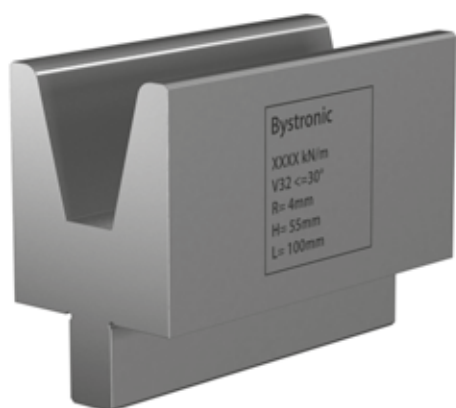

[R] 半径 (mm)*	4
[a] V - 角度	30°
[H] 高度	55

[B] 宽度	48
[D] 深度	33.6

*按需提供其他半径规格

标准长度	零件号
50 mm	64208.0032.5001
55 mm	64208.0032.5002
60 mm	64208.0032.5003
65 mm	64208.0032.5004
70 mm	64208.0032.5005
75 mm	64208.0032.5006
80 mm	64208.0032.5007
85 mm	64208.0032.5008
90 mm	64208.0032.5009
95 mm	64208.0032.5010
100 mm	64208.0032.5011

标准长度	零件号
200 mm	64208.0032.5012
275 mm	64208.0032.5013
300 mm	64208.0032.5014
515 mm	64208.0032.5015
1025 mm sect.	64208.0032.5000



F max 30° = 300 kN/m



16.7 kg/m



凹模镶件 13 mm



V32C/30° H100

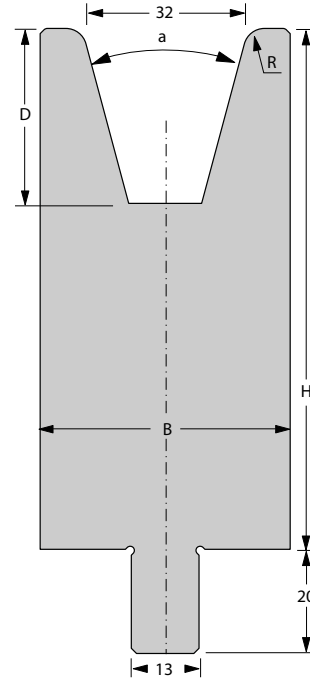

[R] 半径 (mm)*	4
[a] V - 角度	30°
[H] 高度	100

[B] 宽度	48
[D] 深度	33.6

*按需提供其他半径规格

标准长度	零件号
50 mm	64208.0032.5017
55 mm	64208.0032.5018
60 mm	64208.0032.5019
65 mm	64208.0032.5020
70 mm	64208.0032.5021
75 mm	64208.0032.5022
80 mm	64208.0032.5023
85 mm	64208.0032.5024
90 mm	64208.0032.5025
95 mm	64208.0032.5026
100 mm	64208.0032.5027

标准长度	零件号
200 mm	64208.0032.5028
275 mm	64208.0032.5029
300 mm	64208.0032.5016
515 mm	64208.0032.5031
1025 mm sect.	64208.0032.5030



$F_{max} 30^\circ = 300 \text{ kN/m}$



33.7 kg/m



凹模镶件 13 mm



V40C/60° H55

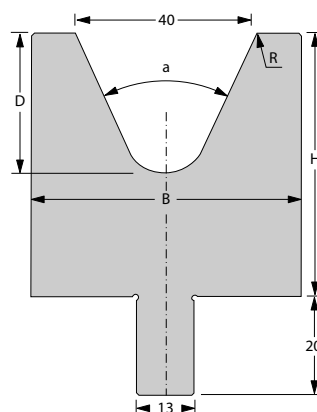
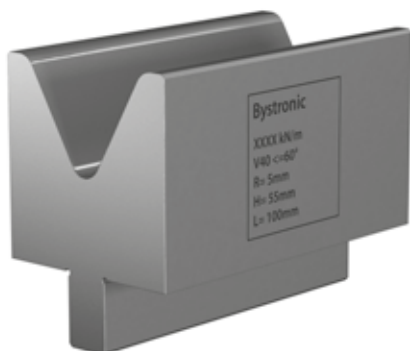

[R] 半径 (mm)*	5
[a] V - 角度	60°
[H] 高度	55

[B] 宽度	55
[D] 深度	29.6

*按需提供其他半径规格

标准长度	零件号
50 mm	64208.0040.5001
55 mm	64208.0040.5002
60 mm	64208.0040.5003
65 mm	64208.0040.5004
70 mm	64208.0040.5005
75 mm	64208.0040.5006
80 mm	64208.0040.5007
85 mm	64208.0040.5008
90 mm	64208.0040.5009
95 mm	64208.0040.5010
100 mm	64208.0040.5011

标准长度	零件号
200 mm	64208.0040.5012
275 mm	64208.0040.5013
300 mm	64208.0040.5014
515 mm	64208.0040.5015
1025 mm sect.	64208.0040.5000



F max 60° = 1800 kN/m



20.5 kg/m



凹模镶件 13 mm



V40C/60° H100

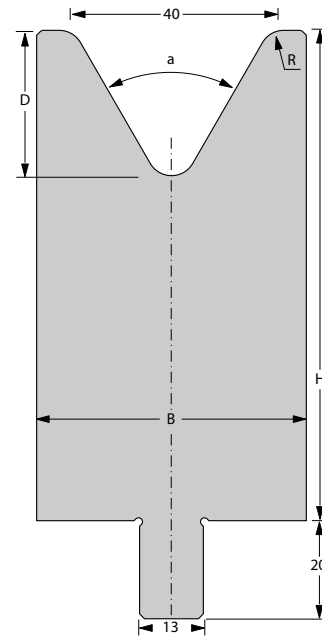

[R] 半径 (mm)*	5
[a] V - 角度	60°
[H] 高度	100

[B] 宽度	55
[D] 深度	29.6

*按需提供其他半径规格

标准长度	零件号
50 mm	64208.0040.5017
55 mm	64208.0040.5018
60 mm	64208.0040.5019
65 mm	64208.0040.5020
70 mm	64208.0040.5021
75 mm	64208.0040.5022
80 mm	64208.0040.5023
85 mm	64208.0040.5024
90 mm	64208.0040.5025
95 mm	64208.0040.5026
100 mm	64208.0040.5027

标准长度	零件号
200 mm	64208.0040.5028
275 mm	64208.0040.5029
300 mm	64208.0040.5016
515 mm	64208.0040.5031
1025 mm sect.	64208.0040.5030



$F_{max} 60^\circ = 1300 \text{ kN/m}$



39.9 kg/m



凹模镶件 13 mm



V50C/60° H55

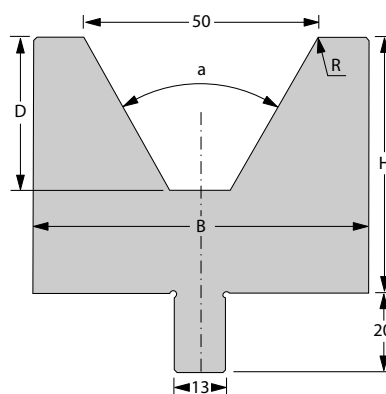
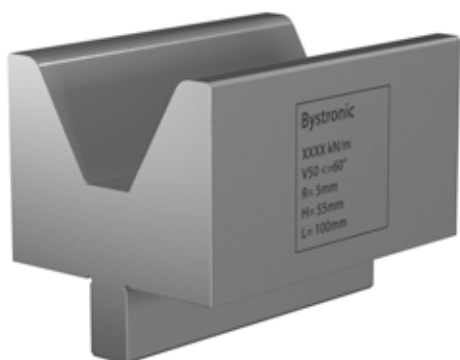

[R] 半径 (mm)*	5
[a] V - 角度	60°
[H] 高度	55

[B] 宽度	70
[D] 深度	30.3

*按需提供其他半径规格

标准长度	零件号
50 mm	64208.0050.5001
55 mm	64208.0050.5002
60 mm	64208.0050.5003
65 mm	64208.0050.5004
70 mm	64208.0050.5005
75 mm	64208.0050.5006
80 mm	64208.0050.5007
85 mm	64208.0050.5008
90 mm	64208.0050.5009
95 mm	64208.0050.5010
100 mm	64208.0050.5011

标准长度	零件号
200 mm	64208.0050.5012
275 mm	64208.0050.5013
300 mm	64208.0050.5014
515 mm	64208.0050.5015
1025 mm sect.	64208.0050.5000



F max 60° = 1200 kN/m



24.5 kg/m



凹模镶件 13 mm



V50C/60° H100

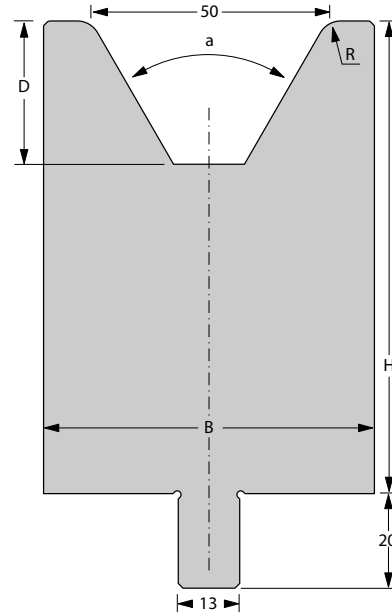

[R] 半径 (mm)*	5
[a] V - 角度	60°
[H] 高度	100

[B] 宽度	70
[D] 深度	30.3

*按需提供其他半径规格

标准长度	零件号
50 mm	64208.0050.5016
55 mm	64208.0050.5017
60 mm	64208.0050.5018
65 mm	64208.0050.5019
70 mm	64208.0050.5020
75 mm	64208.0050.5021
80 mm	64208.0050.5022
85 mm	64208.0050.5023
90 mm	64208.0050.5024
95 mm	64208.0050.5025
100 mm	64208.0050.5026

标准长度	零件号
200 mm	64208.0050.5027
275 mm	64208.0050.5028
300 mm	64208.0050.5029
515 mm	64208.0050.5031
1025 mm sect.	64208.0050.5030



$F_{max} 60^\circ = 2000 \text{ kN/m}$



49.2 kg/m



凹模镶件 13 mm



V60C/60° H65

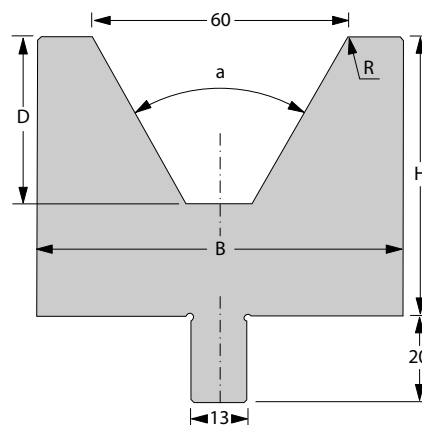
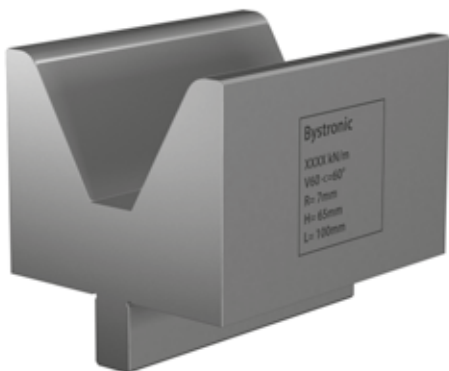

[R] 半径 (mm)*	7
[a] V - 角度	60°
[H] 高度	65

[B] 宽度	80
[D] 深度	39

*按需提供其他半径规格

标准长度	零件号
50 mm	64208.0060.5001
55 mm	64208.0060.5002
60 mm	64208.0060.5003
65 mm	64208.0060.5004
70 mm	64208.0060.5005
75 mm	64208.0060.5006
80 mm	64208.0060.5007
85 mm	64208.0060.5008
90 mm	64208.0060.5009
95 mm	64208.0060.5010
100 mm	64208.0060.5011

标准长度	零件号
200 mm	64208.0060.5012
275 mm	64208.0060.5013
300 mm	64208.0060.5014
515 mm	64208.0060.5031
1025 mm sect.	64208.0060.5000



F max 60° = 1600 kN/m



31.4 kg/m



凹模镶件 13 mm



V60C/60° H100

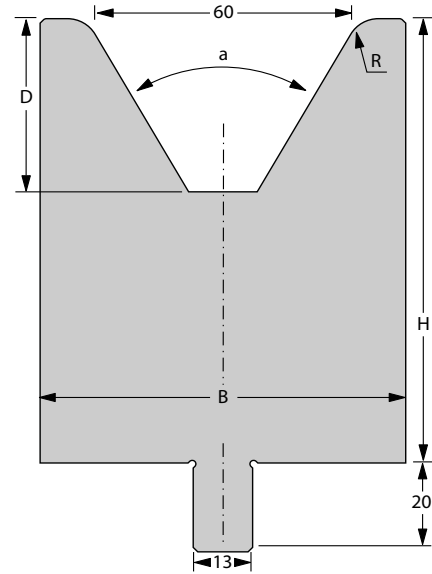

[R] 半径 (mm)*	7
[a] V - 角度	60°
[H] 高度	100

[B] 宽度	80
[D] 深度	39

*按需提供其他半径规格

标准长度	零件号
50 mm	64208.0060.5016
55 mm	64208.0060.5017
60 mm	64208.0060.5018
65 mm	64208.0060.5019
70 mm	64208.0060.5020
75 mm	64208.0060.5021
80 mm	64208.0060.5022
85 mm	64208.0060.5023
90 mm	64208.0060.5024
95 mm	64208.0060.5025
100 mm	64208.0060.5026

标准长度	零件号
200 mm	64208.0060.5015
275 mm	64208.0060.5027
300 mm	64208.0060.5028
1025 mm sect.	64208.0060.5030



F max 60° = 2000 kN/m



53.4 kg/m



凹模镶件 13 mm



V80C/80° H65

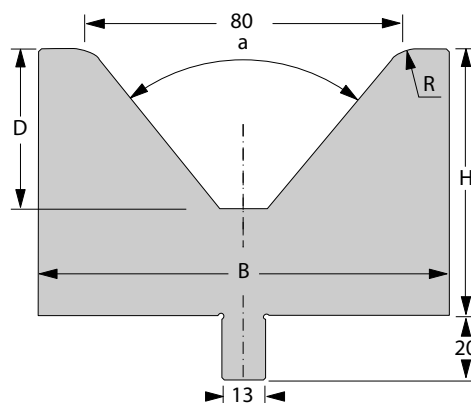
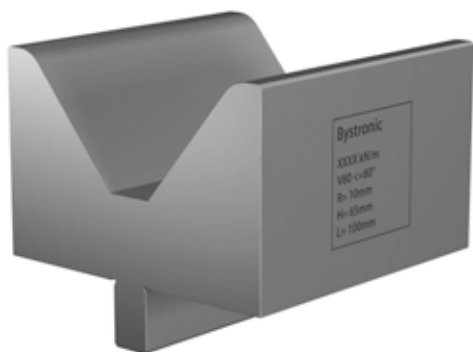

[R] 半径 (mm)*	10
[a] V - 角度	80°
[H] 高度	65

[B] 宽度	100
[D] 深度	38.7

*按需提供其他半径规格

标准长度	零件号
50 mm	64208.0080.5001
55 mm	64208.0080.5002
60 mm	64208.0080.5003
65 mm	64208.0080.5004
70 mm	64208.0080.5005
75 mm	64208.0080.5006
80 mm	64208.0080.5007
85 mm	64208.0080.5008
90 mm	64208.0080.5009
95 mm	64208.0080.5010
100 mm	64208.0080.5011

标准长度	零件号
200 mm	64208.0080.5012
275 mm	64208.0080.5013
300 mm	64208.0080.5014
515 mm	64208.0080.5029
1025 mm sect.	64208.0080.5000



F max 80° = 1400 kN/m



38.6 kg/m



凹模镶件 13 mm



V80C/80° H100

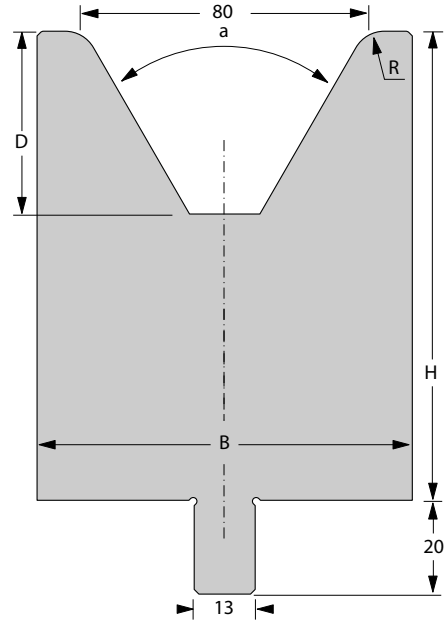

[R] 半径 (mm)*	10
[a] V - 角度	80°
[H] 高度	100

[B] 宽度	100
[D] 深度	38.7

*按需提供其他半径规格

标准长度	零件号
50 mm	64208.0080.5015
55 mm	64208.0080.5016
60 mm	64208.0080.5017
65 mm	64208.0080.5018
70 mm	64208.0080.5019
75 mm	64208.0080.5020
80 mm	64208.0080.5021
85 mm	64208.0080.5022
90 mm	64208.0080.5023
95 mm	64208.0080.5024
100 mm	64208.0080.5025

标准长度	零件号
200 mm	64208.0080.5026
275 mm	64208.0080.5027
300 mm	64208.0080.5028
1025 mm sect.	64208.0080.5030



F max 80° = 1400 kN/m



66.0 kg/m



凹模镶件 13 mm



V100C/80° H85

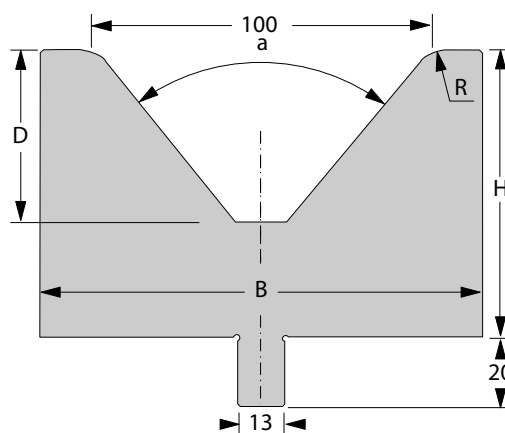
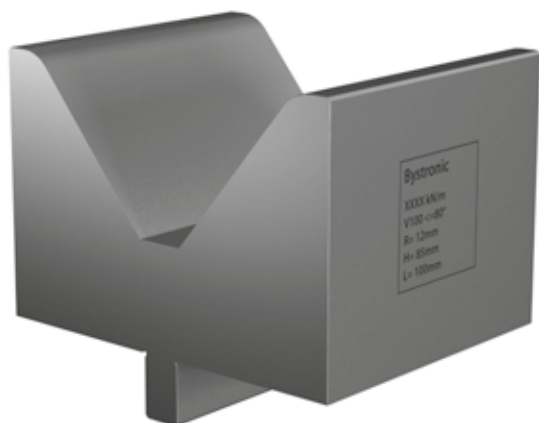

[R] 半径 (mm)*	12
[a] V - 角度	80°
[H] 高度	85

[B] 宽度	125
[D] 深度	50.5

*按需提供其他半径规格

标准长度	零件号
50 mm	64208.0100.5001
55 mm	64208.0100.5002
60 mm	64208.0100.5003
65 mm	64208.0100.5004
70 mm	64208.0100.5005
75 mm	64208.0100.5006
80 mm	64208.0100.5007
85 mm	64208.0100.5008
90 mm	64208.0100.5009
95 mm	64208.0100.5010
100 mm	64208.0100.5011

标准长度	零件号
200 mm	64208.0100.5012
275 mm	64208.0100.5013
300 mm	64208.0100.5014
1025 mm sect.	64208.0100.5000



F max 80° = 1800 kN/m



60.5 kg/m



凹模镶件 13 mm



V120C/80° H105

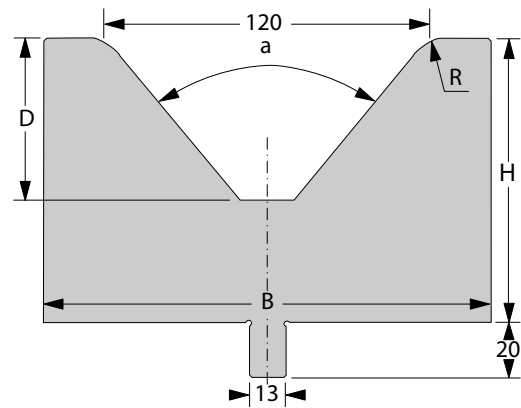
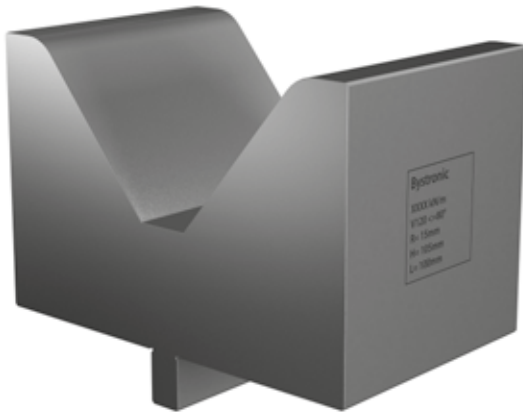

[R] 半径 (mm)*	15
[a] V - 角度	80°
[H] 高度	105

[B] 宽度	160
[D] 深度	59.5

*按需提供其他半径规格

标准长度	零件号
50 mm	64208.0120.5001
55 mm	64208.0120.5002
60 mm	64208.0120.5003
65 mm	64208.0120.5004
70 mm	64208.0120.5005
75 mm	64208.0120.5006
80 mm	64208.0120.5007
85 mm	64208.0120.5008
90 mm	64208.0120.5009
95 mm	64208.0120.5010
100 mm	64208.0120.5011

标准长度	零件号
200 mm	64208.0120.5012
275 mm	64208.0120.5013
300 mm	64208.0120.5014
1025 mm sect.	64208.0120.5000



$F_{max} 80^\circ = 2000 \text{ kN/m}$



101.0 kg/m



凹模镶件 13 mm



V6SC/30° H55

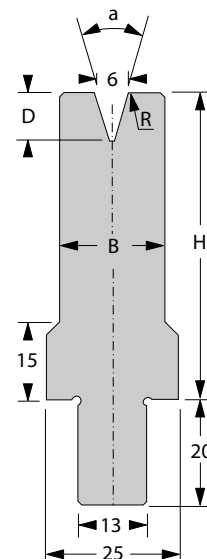

[R] 半径 (mm)*	0.75
[a] V - 角度	30°
[H] 高度	55

[B] 宽度	12
[D] 深度	9.3

*按需提供其他半径规格

标准长度	零件号
50 mm	64208.0006.5101
55 mm	64208.0006.5102
60 mm	64208.0006.5103
65 mm	64208.0006.5104
70 mm	64208.0006.5105
75 mm	64208.0006.5106
80 mm	64208.0006.5107
85 mm	64208.0006.5108
90 mm	64208.0006.5109
95 mm	64208.0006.5110
100 mm	64208.0006.5111

标准长度	零件号
200 mm	64208.0006.5112
275 mm	64208.0006.5113
300 mm	64208.0006.5114
515 mm	64208.0006.5115
1025 mm sect.	64208.0006.5100



F max 30° = 100 kN/m



8.1 kg/m



凹模镶件 13 mm



V6SC/30° H100

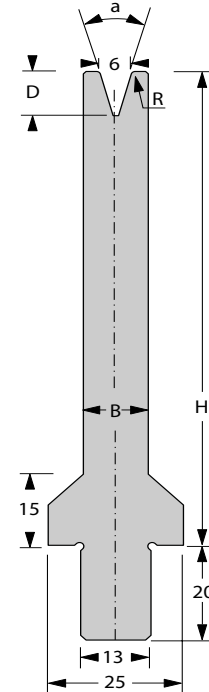

[R] 半径 (mm)*	0.75
[a] V - 角度	30°
[H] 高度	100

[B] 宽度	12
[D] 深度	9.3

*按需提供其他半径规格

标准长度	零件号
50 mm	64208.0006.5151
55 mm	64208.0006.5152
60 mm	64208.0006.5153
65 mm	64208.0006.5154
70 mm	64208.0006.5155
75 mm	64208.0006.5156
80 mm	64208.0006.5157
85 mm	64208.0006.5158
90 mm	64208.0006.5159
95 mm	64208.0006.5160
100 mm	64208.0006.5161

标准长度	零件号
200 mm	64208.0006.5162
275 mm	64208.0006.5163
300 mm	64208.0006.5164
515 mm	64208.0006.5165
1025 mm sect.	64208.0006.5150



$F_{\max} 30^\circ = 100 \text{ kN/m}$



12.3 kg/m



凹模镶件 13 mm



V8SC/30° H55

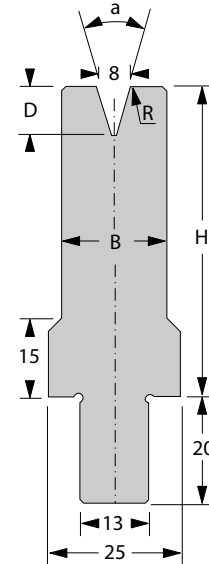
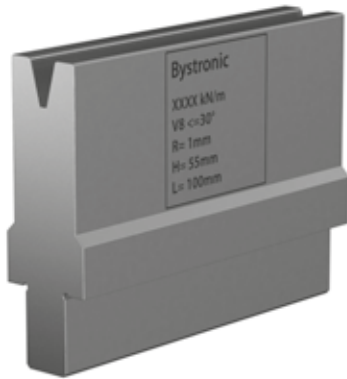

[R] 半径 (mm)*	1
[a] V - 角度	30°
[H] 高度	55

[B] 宽度	14
[D] 深度	11.2

*按需提供其他半径规格

标准长度	零件号
50 mm	64208.0008.5102
55 mm	64208.0008.5103
60 mm	64208.0008.5104
65 mm	64208.0008.5105
70 mm	64208.0008.5106
75 mm	64208.0008.5107
80 mm	64208.0008.5108
85 mm	64208.0008.5109
90 mm	64208.0008.5110
95 mm	64208.0008.5111
100 mm	64208.0008.5112

标准长度	零件号
200 mm	64208.0008.5113
275 mm	64208.0008.5114
300 mm	64208.0008.5115
515 mm	64208.0008.5116
1025 mm sect.	64208.0008.5100



F max 30° = 100 kN/m



8.7 kg/m



凹模镶件 13 mm



V8SC/30° H100

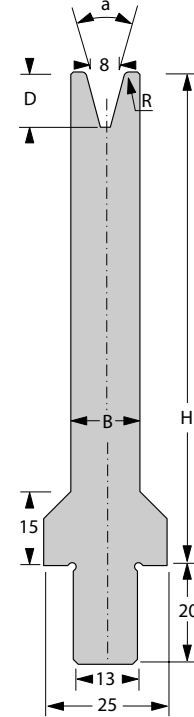

[R] 半径 (mm)*	1
[a] V - 角度	30°
[H] 高度	100

[B] 宽度	14
[D] 深度	11.2

*按需提供其他半径规格

标准长度	零件号
50 mm	64208.0008.5151
55 mm	64208.0008.5152
60 mm	64208.0008.5153
65 mm	64208.0008.5154
70 mm	64208.0008.5155
75 mm	64208.0008.5156
80 mm	64208.0008.5157
85 mm	64208.0008.5158
90 mm	64208.0008.5159
95 mm	64208.0008.5160
100 mm	64208.0008.5161

标准长度	零件号
200 mm	64208.0008.5162
275 mm	64208.0008.5163
300 mm	64208.0008.5164
515 mm	64208.0008.5166
1025 mm sect.	64208.0008.5150



$F_{max} 30^\circ = 1000 \text{ kN/m}$



13.7 kg/m



凹模镶件 13 mm



V10SC/30° H55

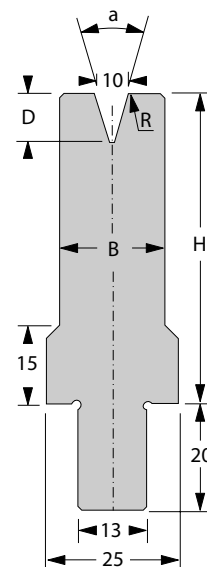

[R] 半径 (mm)*	1
[a] V - 角度	30°
[H] 高度	55

[B] 宽度	16
[D] 深度	14.9

*按需提供其他半径规格

标准长度	零件号
50 mm	64208.0010.5101
55 mm	64208.0010.5102
60 mm	64208.0010.5103
65 mm	64208.0010.5104
70 mm	64208.0010.5105
75 mm	64208.0010.5106
80 mm	64208.0010.5107
85 mm	64208.0010.5108
90 mm	64208.0010.5109
95 mm	64208.0010.5110
100 mm	64208.0010.5111

标准长度	零件号
200 mm	64208.0010.5112
275 mm	64208.0010.5113
300 mm	64208.0010.5114
515 mm	64208.0010.5115
1025 mm sect.	64208.0010.5100



F max 30° = 100 kN/m



9.1 kg/m



凹模镶件 13 mm



V10SC/30° H100

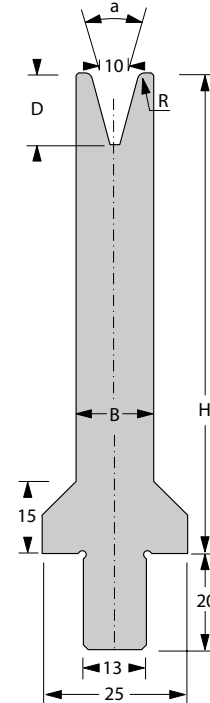

[R] 半径 (mm)*	1
[a] V - 角度	30°
[H] 高度	100

[B] 宽度	16
[D] 深度	14.9

*按需提供其他半径规格

标准长度	零件号
50 mm	64208.0010.5117
55 mm	64208.0010.5118
60 mm	64208.0010.5119
65 mm	64208.0010.5120
70 mm	64208.0010.5121
75 mm	64208.0010.5122
80 mm	64208.0010.5123
85 mm	64208.0010.5124
90 mm	64208.0010.5125
95 mm	64208.0010.5126
100 mm	64208.0010.5127

标准长度	零件号
200 mm	64208.0010.5128
275 mm	64208.0010.5129
300 mm	64208.0010.5130
515 mm	64208.0010.5131
1025 mm sect.	64208.0010.5116



$F_{max} 30^\circ = 100 \text{ kN/m}$



14.7 kg/m



凹模镶件 13 mm



V12SC/30° H55

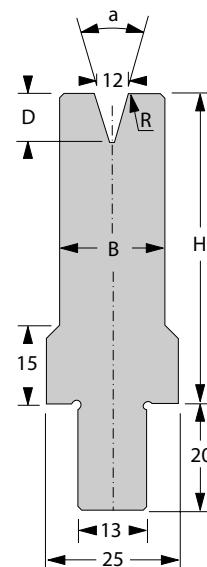
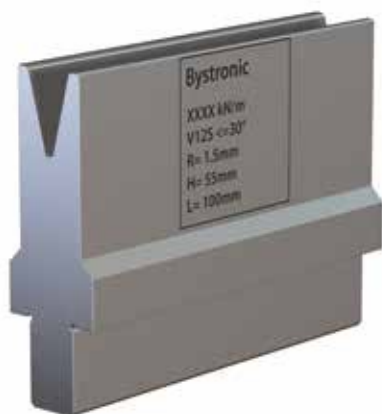

[R] 半径 (mm)*	1.5
[a] V - 角度	30°
[H] 高度	55

[B] 宽度	18
[D] 深度	18.6

*按需提供其他半径规格

标准长度	零件号
50 mm	64208.0012.5101
55 mm	64208.0012.5102
60 mm	64208.0012.5103
65 mm	64208.0012.5104
70 mm	64208.0012.5105
75 mm	64208.0012.5106
80 mm	64208.0012.5107
85 mm	64208.0012.5108
90 mm	64208.0012.5109
95 mm	64208.0012.5110
100 mm	64208.0012.5111

标准长度	零件号
200 mm	64208.0012.5112
275 mm	64208.0012.5113
300 mm	64208.0012.5114
515 mm	64208.0012.5115
1025 mm sect.	64208.0012.5100



F max 30° = 100 kN/m



9.5 kg/m



凹模镶件 13 mm



V12SC/30° H100

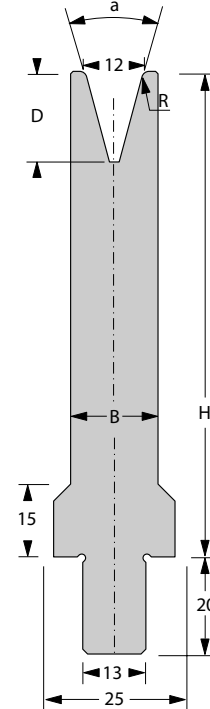

[R] 半径 (mm)*	1.5
[a] V - 角度	30°
[H] 高度	100

[B] 宽度	18
[D] 深度	18.6

*按需提供其他半径规格

标准长度	零件号
50 mm	64208.0012.5117
55 mm	64208.0012.5118
60 mm	64208.0012.5119
65 mm	64208.0012.5120
70 mm	64208.0012.5121
75 mm	64208.0012.5122
80 mm	64208.0012.5123
85 mm	64208.0012.5124
90 mm	64208.0012.5125
95 mm	64208.0012.5126
100 mm	64208.0012.5127

标准长度	零件号
200 mm	64208.0012.5128
275 mm	64208.0012.5129
300 mm	64208.0012.5130
515 mm	64208.0012.5131
1025 mm sect.	64208.0012.5116



$F_{max} 30^\circ = 100 \text{ kN/m}$



15.9 kg/m



凹模镶件 13 mm



折边模具

复平模具

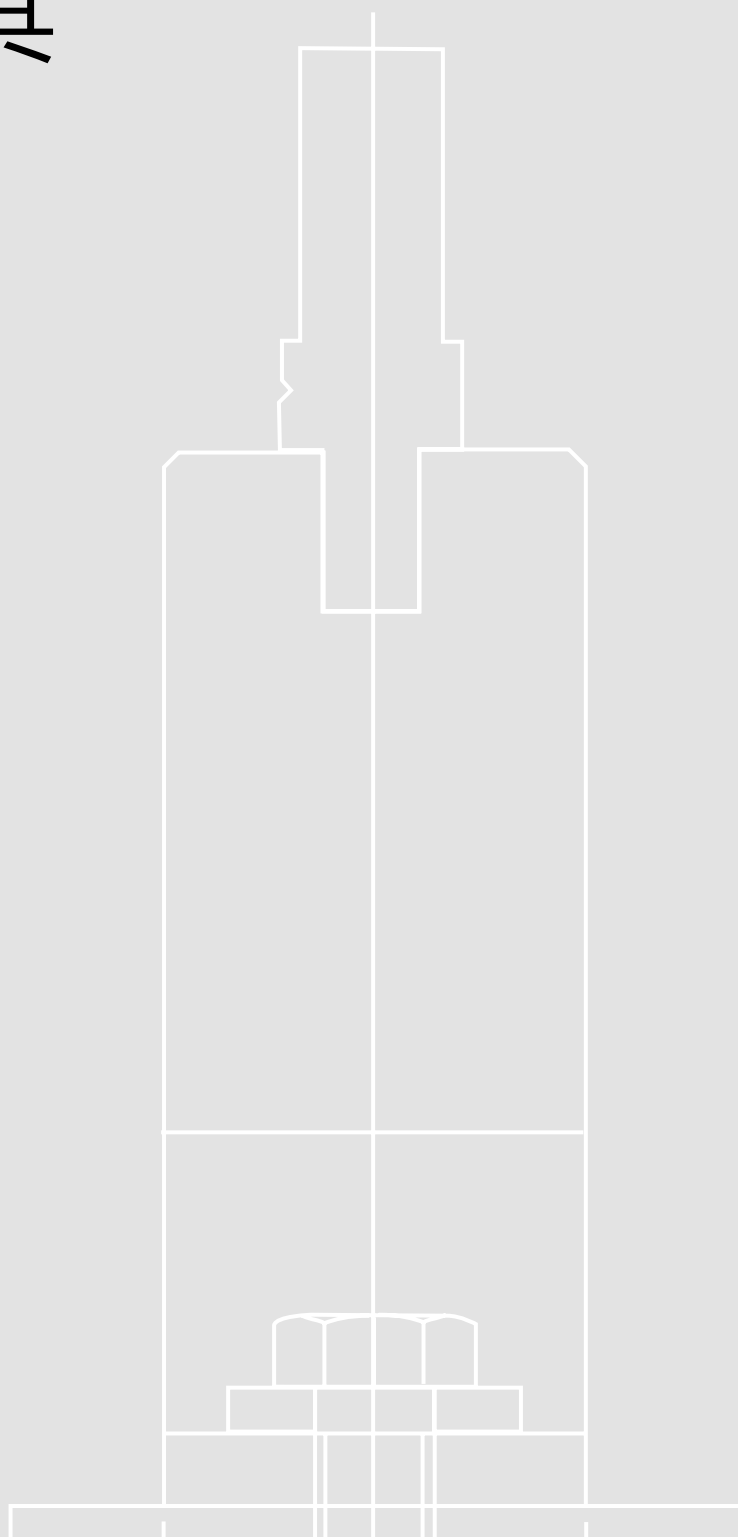





P11 RF-AC H250

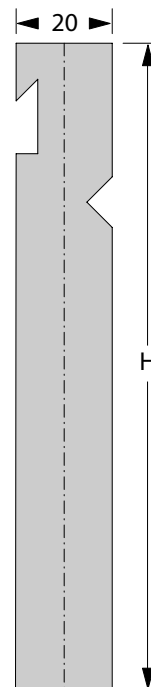

[B] 宽度	20
[H] 高度	250

标准长度	零件号
30 mm	65208.0011.5001
35 mm	65208.0011.5002
40 mm	65208.0011.5003
45 mm	65208.0011.5004
50 mm	65208.0011.5005
55 mm	65208.0011.5006
60 mm	65208.0011.5007
65 mm	65208.0011.5008
70 mm	65208.0011.5009
75 mm	65208.0011.5010
80 mm	65208.0011.5011

标准长度	零件号
85 mm	65208.0011.5012
90 mm	65208.0011.5013
95 mm	65208.0011.5014
100 mm	65208.0011.5015
200 mm	65208.0011.5016
275 mm	65208.0011.5017
300 mm	65208.0011.5018
515 mm	65208.0011.5023
1175 mm sect.	65208.0011.5000



F max = 1400 kN/m



35.9 kg/m



98.0 mm



P900/8 RF-AC/30° H250

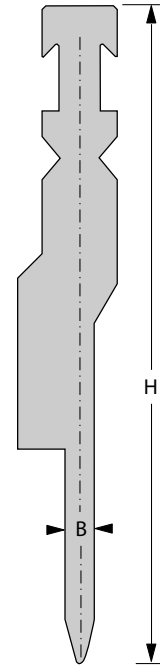

[B] 宽度	26.5
[H] 高度	250

标准长度	零件号
30 mm	65208.0900.5002
35 mm	65208.0900.5003
40 mm	65208.0900.5004
45 mm	65208.0900.5005
50 mm	65208.0900.5006
55 mm	65208.0900.5007
60 mm	65208.0900.5008
65 mm	65208.0900.5009
70 mm	65208.0900.5010
75 mm	65208.0900.5011
80 mm	65208.0900.5012

标准长度	零件号
85 mm	65208.0900.5013
90 mm	65208.0900.5014
95 mm	65208.0900.5015
100 mm	65208.0900.5016
200 mm	65208.0900.5017
275 mm	65208.0900.5018
300 mm	65208.0900.5019
515 mm	65208.0900.5020
1175 mm sect.	65208.0900.5000



F max = 1000 kN/m



29.2 kg/m



P900/10 RF-AC/30° H250

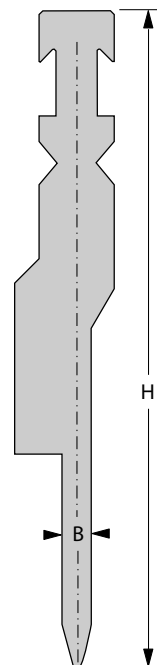

[B] 宽度	26.5
[H] 高度	250

标准长度	零件号
30 mm	65208.0900.5050
35 mm	65208.0900.5041
40 mm	65208.0900.5042
45 mm	65208.0900.5043
50 mm	65208.0900.5044
55 mm	65208.0900.5045
60 mm	65208.0900.5046
65 mm	65208.0900.5047
70 mm	65208.0900.5048
75 mm	65208.0900.5049
80 mm	65208.0900.5040

标准长度	零件号
85 mm	65208.0900.5051
90 mm	65208.0900.5052
95 mm	65208.0900.5053
100 mm	65208.0900.5054
200 mm	65208.0900.5055
275 mm	65208.0900.5056
300 mm	65208.0900.5057
515 mm	65208.0900.5058
1175 mm sect.	65208.0900.5059



F max = 1000 kN/m



29.2 kg/m



P900/12 RF-AC/30° H250

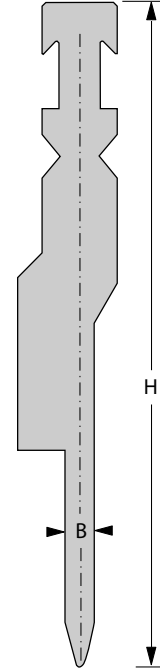

[B] 宽度	26.5
[H] 高度	250

标准长度	零件号
30 mm	65208.0900.5021
35 mm	65208.0900.5022
40 mm	65208.0900.5023
45 mm	65208.0900.5024
50 mm	65208.0900.5025
55 mm	65208.0900.5026
60 mm	65208.0900.5027
65 mm	65208.0900.5028
70 mm	65208.0900.5029
75 mm	65208.0900.5030
80 mm	65208.0900.5031

标准长度	零件号
85 mm	65208.0900.5032
90 mm	65208.0900.5033
95 mm	65208.0900.5034
100 mm	65208.0900.5035
200 mm	65208.0900.5036
275 mm	65208.0900.5037
300 mm	65208.0900.5001
515 mm	65208.0900.5038
1175 mm sect.	65208.0900.5039



F max = 1000 kN/m



34.3 kg/m



V-Flat B40

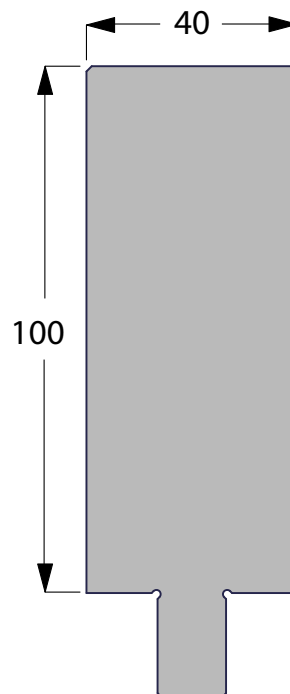

[B] 宽度	40
[H] 高度	100

标准长度	零件号
50 mm	64208.0000.5001
55 mm	64208.0000.5002
60 mm	64208.0000.5003
65 mm	64208.0000.5004
70 mm	64208.0000.5005
75 mm	64208.0000.5006
80 mm	64208.0000.5007
85 mm	64208.0000.5008
90 mm	64208.0000.5009
95 mm	64208.0000.5010
100 mm	64208.0000.5011

标准长度	零件号
200 mm	64208.0000.5012
275 mm	64208.0000.5013
300 mm	64208.0000.5014
515 mm	64208.0000.5015
1025 mm sect.	64208.0000.5000



F max 30° = 2000 kN/m



35.5 kg/m



凹模镶件 13 mm



V900/08C

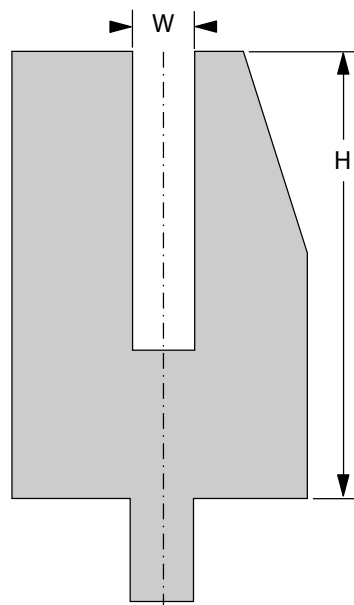

[B] 宽度	55
[H] 高度	85

标准长度	零件号
50 mm	64208.0900.5003
55 mm	64208.0900.5004
60 mm	64208.0900.5005
65 mm	64208.0900.5006
70 mm	64208.0900.5007
75 mm	64208.0900.5008
80 mm	64208.0900.5009
85 mm	64208.0900.5010
90 mm	64208.0900.5011
95 mm	64208.0900.5012
100 mm	64208.0900.5013

标准长度	零件号
200 mm	64208.0900.5014
275 mm	64208.0900.5015
300 mm	64208.0900.5002
515 mm	64208.0900.5016
1025 mm sect.	64208.0900.5000



$F_{max} 30^\circ = 250 \text{ kN/m}$



35.5 kg/m



凹模镶件 13 mm



V900/10C

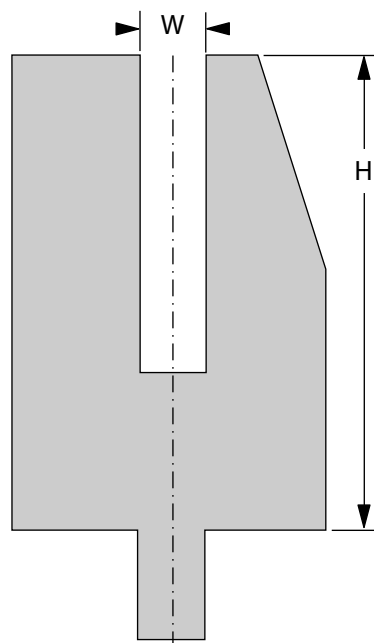

[B] 宽度	55
[H] 高度	85

标准长度	零件号
50 mm	64208.0900.5032
55 mm	64208.0900.5033
60 mm	64208.0900.5034
65 mm	64208.0900.5047
70 mm	64208.0900.5035
75 mm	64208.0900.5036
80 mm	64208.0900.5037
85 mm	64208.0900.5038
90 mm	64208.0900.5039
95 mm	64208.0900.5040
100 mm	64208.0900.5041

标准长度	零件号
200 mm	64208.0900.5042
275 mm	64208.0900.5043
300 mm	64208.0900.5044
515 mm	64208.0900.5045
1025 mm sect.	64208.0900.5046



F max 30° = 250 kN/m



32.0 kg/m



凹模镶件 13 mm



V900/12C

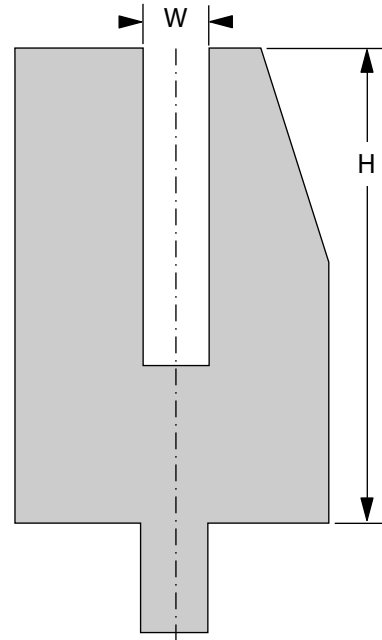

[B] 宽度	55
[H] 高度	85

标准长度	零件号
50 mm	64208.0900.5017
55 mm	64208.0900.5018
60 mm	64208.0900.5019
65 mm	64208.0900.5020
70 mm	64208.0900.5021
75 mm	64208.0900.5022
80 mm	64208.0900.5023
85 mm	64208.0900.5024
90 mm	64208.0900.5025
95 mm	64208.0900.5026
100 mm	64208.0900.5027

标准长度	零件号
200 mm	64208.0900.5028
275 mm	64208.0900.5029
300 mm	64208.0900.5001
515 mm	64208.0900.5030
1025 mm sect.	64208.0900.5031



$F_{max} 30^\circ = 250 \text{ kN/m}$



31.0 kg/m



凹模镶件 13 mm



全球网点联系方式

Bystronic Laser AG
Industriestrasse 21
3362 Niederönz
Switzerland
电话: +41 62 956 33 33
电子邮箱: info.laser@bystronic.com

Bystronic Australia Pty. Ltd.
4 Latchford Street
Cranbourne West VIC 3977
Australia
电话: +61 1300 975 761
电子邮箱: info.au@bystronic.com

Bystronic Austria GmbH
Schärdinger Straße 15
4061 Pasching
Austria
电话: +43 7229 64411
电子邮箱: office.at@bystronic.com

Bystronic do Brasil Ltda.
Rua Parma 203
83413-587 – Colombo – PR
Brazil
电话: +55 41 3666 9000
电子邮箱: bystronic.br@bystronic.com

Bystronic Canada Ltd
3330 Ridgeway Drive, Unit #11
Mississauga, ON L5L 5Z9
Canada
电话: +1 905 890 2999
E-Mail sales.canada@bystronic.com

百超(天津)激光技术有限公司
天津空港经济区
西十道46号
邮编:
300308
电话: +86 22 5980 1888
电子邮箱: info.tj.cn@bystronic.com

Bystronic Czech Republic s.r.o.
Turanka 115/1222
627 00 Brno Slatina
Czech Republic
电话: +420 532 123 314
电子邮箱: info.cz@bystronic.com

Bystronic Ibérica, S.A.
Avda. Tenerife n° 2
Edificio 1, Planta 3, Oficina D
28700 San Sebastián de los Reyes
(Madrid) España
电话: +34 91 654 48 78
电子邮箱: sales.es@bystronic.com

Bystronic France SAS
Parc Technopolis
3, Avenue du Canada
91940 Les Ulis Cedex
France
电话: +33 1 69 41 99 84
电子邮箱: info.fr@bystronic.com

Bystronic Maschinenbau GmbH
Mühlhäuser Strasse 3
99867 Gotha
Germany
电话: +49 3621 38 30
电子邮箱: info.bending@bystronic.com

Bystronic Deutschland GmbH
Römerstrasse 14
71296 Heimsheim
Germany
电话: +49 7033 46 99 0
电子邮箱: info.de@bystronic.com

Bystronic Magyarország Kft.
Budaörs Business Center
Puskás Tivadarút 5
2040 Budaörs
Hungary
电话: +36 23 610 433
电子邮箱: info.hu@bystronic.com

Bystronic Laser India (Pvt) Ltd.
7C, Tadiwala Road
Next to Hotel Pancharatna
Pune 411 001
India
电话: +91 20 67294800
电子邮箱: info.in@bystronic.com

Bystronic Italia SRL
Via del Lavoro, 30
20813 Bovisio-Masciago
Italia
电话: +39 0362 5993 1
电子邮箱: sales.it@bystronic.com

Bystronic Japan, Ltd.
2-95-3 Inadaira Musashimurayama-shi
Tokyo 208-0023
Japan
电话: +81 42 506 8271
电子邮箱: Cesar.Mujica@bystronic.com

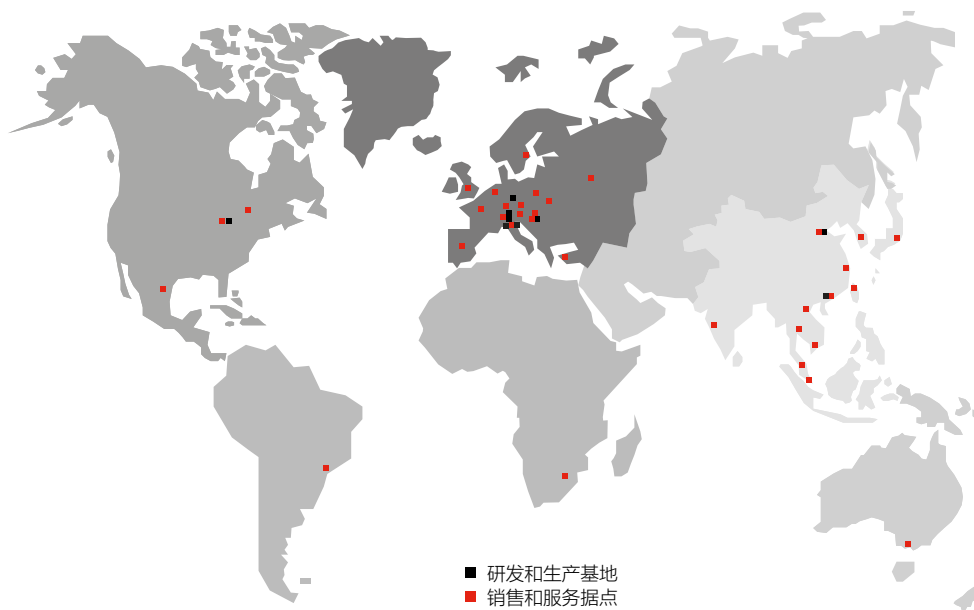



Bystronic Laser Pte. Ltd.
(Representative Office)
Level 8, MCT Tower, Sky Park,
One City, Jalan USJ 25/1
Subang Jaya
47650 Selangor
Malaysia
电话: +60 3 8022 8268

Bystronic Mexico S.A. de C.V.
Helios 401 A, Parque Industrial FINSA
Apodaca
66600 Nuevo León
Mexico
电话: +52 81 2133 7600
电子邮箱: sales.mexico@bystronic.com

Bystronic Benelux B.V.
Duurzaamheidsring 11
4231 EX Meerkerk
Nederland
电话: +31 184 611 020
电子邮箱: sales.benelux@bystronic.com

Bystronic Korea, Ltd.
3F Bystronic Bldg,
32-18, LS-ro
91 Beon-gil, Dongan-gu Anyang-si
14119 Gyeonggi-do
Korea
电话: +82 31 389 9800
电子邮箱: info.kr@bystronic.com

Bystronic Polska Sp. z o.o.
Ul. Sokolowska 47
PL-05-806 Sokolów
Poland
电话: +48 22 331 37 70
电子邮箱: info.pl@bystronic.com

S.C. Bystronic Laser S.R.L.
Str. Poienelor no. 5
Industrial Pro Roman Park
500419 Brasov
Romania
电话: +40 268 322 140
电子邮箱: info.ro@bystronic.com

Bystronic Laser
Zorge Street, 9A
Stroenie 2 (Building 2)
125252 Moscow
Russia
电话: +7 495 984 71 44
电子邮箱: info.ru@bystronic.com

百超(上海)精密机床有限公司
上海市长宁区
福泉北路 388 号
A 座 602
邮编: 200335
电话: +86 21 6082 9300
电子邮箱: info.sha.cn@bystronic.com

Bystronic Pte. Ltd.
Thye Hong Centre
2 Leng Kee Road #02-04
159086 Singapore
电话: +65 6472 6300
电子邮箱: info.sg@bystronic.com

Bystronic Scandinavia AB
Metallvägen 30A
195 72 Rosersberg
Sverige
电话: +46 (0)8 594 415 50
电子邮箱: Services.SE@bystronic.com

Bystronic Sales AG
Industriestrasse 21
3362 Niederönz
Switzerland
电话: +41 62 956 37 83
电子邮箱: info.sales@bystronic.com

百超国际激光有限公司
中国台湾新北市
五股区五权路 66 号
邮编: 248
电话: +886 2 2299 2699
电子邮箱: hotline.tw@bystronic.com

Bystronic Lazer ve Su Isinlari
Makineleri Sanayi ve Ticaret Ltd. Sti.
Serifali Mevkii, Barbaros Caddesi
No: 66 K:1
34775 Ümraniye/Istanbul
Turkey
电话: +90 216 464 6160
电子邮箱: info.tr@bystronic.com

LLC Bystronic Ukraine
59 Zhylyanskaya Street
Diplomat Hall, 2nd floor, Office 207
1033 Kyiv
Ukraine
电话: +380 44 569 74 37
电子邮箱: info.cis@bystronic.com

Bystronic UK Ltd.
6 Wayside Business Park
Wilson's Lane
Coventry
Warwickshire CV6 6NY
United Kingdom
电话: +44 (0)844 848 5850
电子邮箱: sales.uk@bystronic.com

Bystronic Inc.
2200 West Central Road
US-Hoffman Estates
IL 60192
USA
电话: +1 847 214 0300
电子邮箱: sales.us@bystronic.com

Bystronic Vietnam Co. Ltd.
38/7 Truong Chinh Str.
Tan Thoi Nhat Ward
District 12
Hochiminh City
Vietnam
电话: +84 28 3719 2278
电子邮箱: Anhtuan.Ha@bystronic.com

