

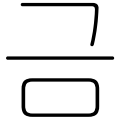



Best choice.

절단. 절곡. 자동화 시스템.

Bystronic

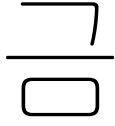
Bystronic  
Bystronic   RF-AC

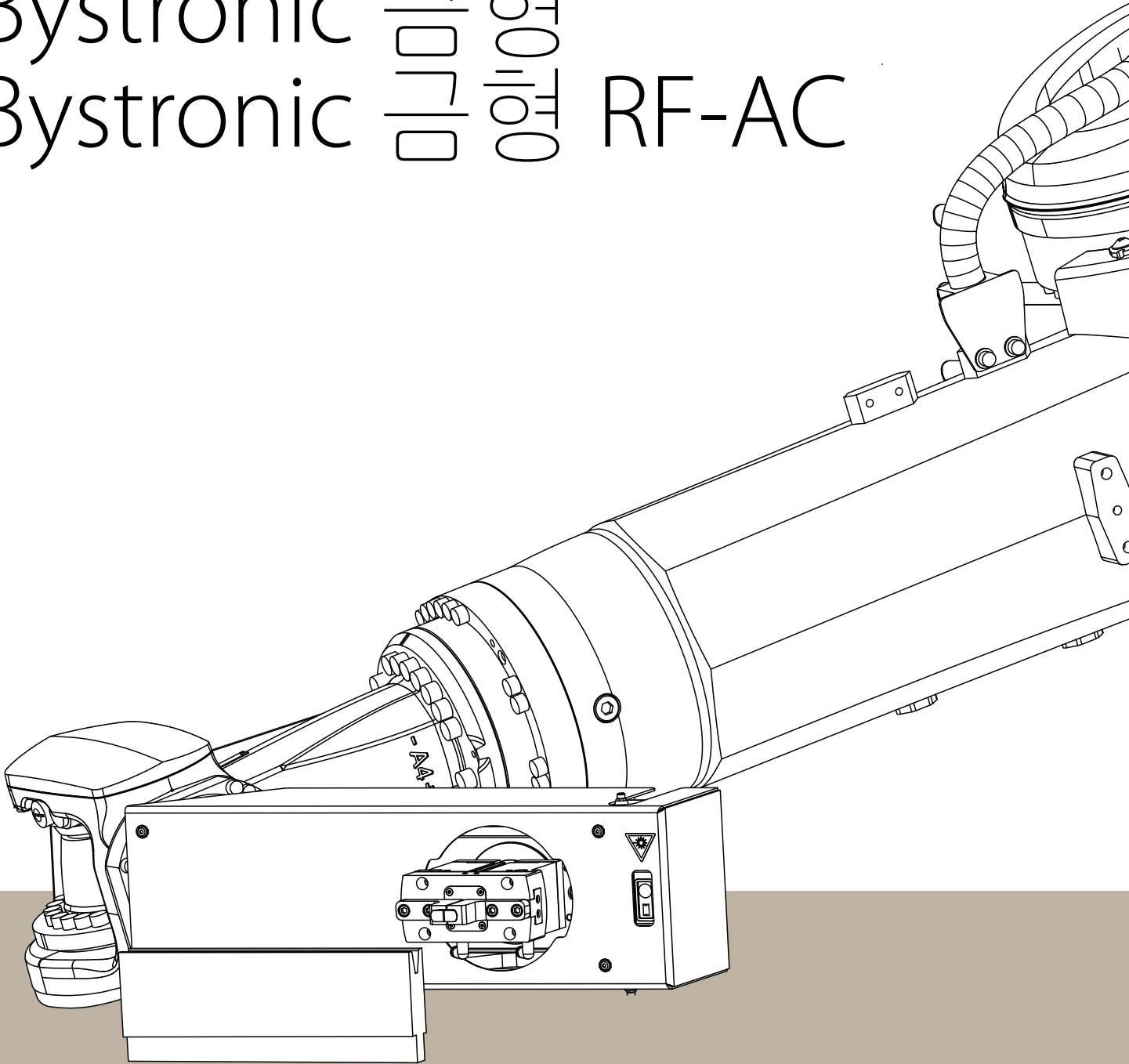



목차

기본 사항	3
카탈로그에 사용된 아이콘	3
에어 절곡 관련 계산 기본 사항	4
툴 교환 작동 방식.....	8
V자 모양	9
분할	10
상부 툴.....	14
상부 툴 분할.....	16
하부 툴.....	22
하단 테이블 옵션.....	24
분할 다이.....	25
헤밍 금형	60
전 세계 지사 연락처.....	70



기본 사항

카탈로그에 사용된 아이콘



경도: 58 - 62 HRC



허용되는 최대 하중



최대 박스 깊이



무게



역방향 금형

본 카탈로그에서 다루는 장비는 다음과 같습니다.

Xpert Tool Changer - XTC

Modular Tool Changer - MTC

Bending Cell - BC



에어 절곡 관련 계산 기본 사항

에어 절곡을 위한 성능 차트

제시된 데이터는 1 m 길이에 인장 강도 $R_m = 420 \text{ N/mm}^2$ 의 절곡 자재에 기반하여 계산된 값입니다.

V	6	8	10	12	16	18	20	24	32	40	50	60	80	
R	1	1.2	1.6	2	2.5	2.8	3	3.5	5	6	8	9.5	12	
t	F 절곡력 [kN]/1 m 절곡 길이													
a	최소 플랜지 길이 [mm]													
0.5	25													
	4.3													
0.8	70	48												
	4.6	5.7												
1	115	80	60											
	5	6	7											
1.2		120	90	70										
		6	7.5	8.5										
1.5			150	120										
			8	9										
2.0				235	160	135	120	95						
				10	12	13	14.5	17						
2.5					265	225	200	155	110					
					12.5	14	15.5	17.5	23					
3.0							300	240	165	125				
							15.5	17.5	23.5	28				
4.0									315	235	180			
									25	29	35			
5.0									535	430	310	250		
									26	31	35.5	43		
6.0										610	450	360		
										32	36	44		
8.0											880	690	470	
											40	46	57	
10													800	
													60	
12														1200
														62
16														
18														
20														

흑피가 있는 철판의 경우 절곡력이 1.05-1.1배만큼 늘어납니다



100	120	130	140	150	160	180	190	200	230	260	290	320	V
15.5	19	21	23	24.5	26	28	30	32	36	40	45	50	R
F 절곡력 [kN]/1 m 절곡 길이													t
a 최소 플랜지 길이 [mm]													
													0.5
													0.8
													1
													1.2
													1.5
													2.0
													2.5
													3.0
													4.0
													5.0
													6.0
360													8.0
71													10
600	470	430	390										12
71	85	92	100										16
900	710	650	580	550	500								18
73	86	92	100	105	115								20
	1400	1250	1150	1050	950	810	800	710	600				
	90	98	105	110	115	130	135	140	160				
			1480	1350	1250	1100	1000	950	800	700	600		
			105	110	120	130	135	140	160	180	205		
						1400	1300	1200	1000	900	850	700	
						135	140	145	165	180	205	225	

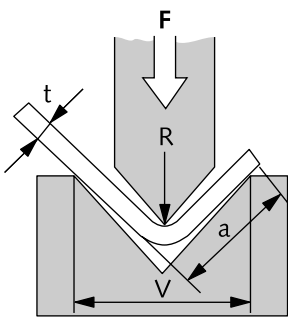

내부 반경 R은 다이 개구부 V의 약 16% 정도 됩니다.



에어 절곡 관련 계산 기본 사항

계산 공식

에어 절곡 시 권장하는 하부 공구 개구부 V

자재 두께	t	0.5-2.5 mm	3-8 mm	9-10 mm	> 12 mm
하부 공구 개구부	V	6 × t	8 × t	10 × t	12 × t

자재별 절곡력

알루미늄	Rm = 300 N/mm ²	F = F (table) × 0.65
연강	Rm = 420 N/mm ²	F = F (table)
스테인레스 연강	Rm = 700 N/mm ²	F = F (table) × 1.6

에어 절곡 시 절곡력 결정(기준 데이터)

$$F = \frac{Rm \times t^2}{V} \times \left(1 + \frac{4 \times t}{V}\right)$$

변환: Rm = 인장 강도 [N/mm²]

10 N = 1 Kg

10 kN = 1 t

최소 내부 반경 R을 위한 변환

두께 t	1	2	3	4	5	6	8	10	12	16	18	20
최소 R	1	2	3	5	6	8	12	16	20	28	36	40



인장 강도

자재		인장 강도	
미국식	유럽식	KPSI	N/mm ²
6061 Aluminum	Alu 50	42	290
5052 Aluminum	Alu 35	44	303
1010 Mild steel	DC01	53	366
A536-80 G 60-40-18	GGG-40	58	400
A 351 G CF 8	G-X 6CrNi 18 9	65	450
A 572 G50	S 355 MC	80	550
Domex 80	S 420 MC	80	550
A 36	S 235 JR	80	552
304 Stainless	Inox V2A	85	586
316 Stainless	Inox V4A	87	600
A 572 G 65	S 460 MC	95	655
Domex 100	S 500 MC	102	700
Domex 550	S 550 MC	110	760
Domex 600	S 600 MC	119	820
Weldox 700	Weldox 700	123	850
Domex 650	S 650 MC	128	880
Domex 700	S 700 MC	138	950
4140 Low alloy	42 CrMo 4	145	1000
Weldox 900	Weldox 900	149	1030
Weldox 960	Weldox 960	154	1060
Hardox 400	Hardox 400	181	1250
Hardox 500	Hardox 500	225	1550

고강도 자재 절곡 시에는 담당자에게 문의해주시기 바랍니다.



틀 교환 작동 방식

스마트한 자동화 시스템으로 신속하고 정확한 틀 교환

- 자동화된 상부 틀 및 하부 틀 교환 방식으로 시간 절약 및 절곡 품질 향상
- 대형 금형(최대 V80 / BC 및 MTC 최대 V120)의 경우에도 상부 빔 및 하부 빔의 클램핑 시스템에 금형 세트를 오류 없이 정밀하게 포지셔닝 가능
- 언제든지 간편하게 금형 확장 가능: 지능형 센서 기술을 통해 새로운 금형을 자동으로 탐지하고 틀 매거진에 통합 가능
- 상부 틀이 자동으로 회전되어 보다 다양한 절곡 작업 가능
- 모든 금형이 장비 내에 준비된 상태로 유지되어 인체공학성 및 취급성이 매우 뛰어남
- 절곡 테이블의 자동 청소 기능으로 정밀하고 원활하게 절곡 부품 가공 진행 가능



* 틀링 최대 무게:

그리퍼 XTC	- 최대 15.0 kg
그리퍼 BC/MTC	- 최대 25.0 kg



V자 모양

상부 툴

상부 툴의 뒷면에 V자 모양이 여러 개 있습니다. P4 및 P5 같은 비대칭 펀치에도 전면에 V자 모양이 여러 개 있습니다.

높이가 250 mm인 P2, P3, P4, P5, P6, P7, P8, P9, P11 및 P900 타입의 펀치를 핸들링할 수 있습니다. 350 mm의 높이는 요청에 따라 툴링 가능합니다.

분할은 30 mm 길이부터 시작해서 최대 515 mm*까지 가능합니다.

하부 툴

하부 툴은 뒷면에 V자 모양이 하나 있어 이를 통해 로봇이 툴을 핸들링할 수 있습니다. V6부터 최대 V120 이하의 인서트를 사용할 수 있습니다**.

분할은 50 mm 길이부터 시작해서 최대 515 mm*까지 가능합니다.

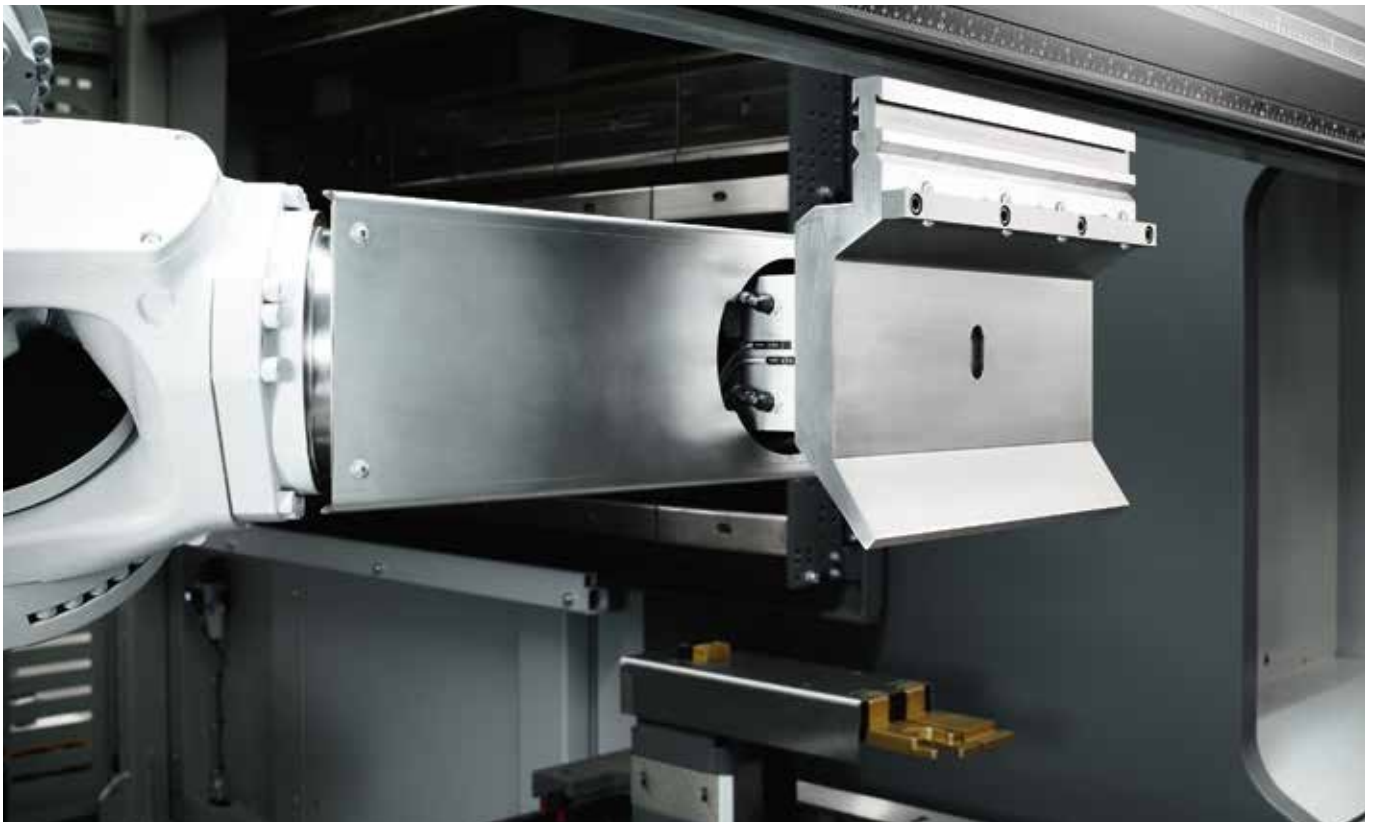

* 515 mm 정도의 부품은 요청시 또는 BC/MTC에서 제공됩니다.

** 최대 V80 이하의 다이 인서트는 XTC에 의해 취급됩니다.

최대 V120 이하의 다이 인서트는 BC/MTC에 의해 취급됩니다.



분할

Xpert Tool Changer, MTC, BC에 적용됨

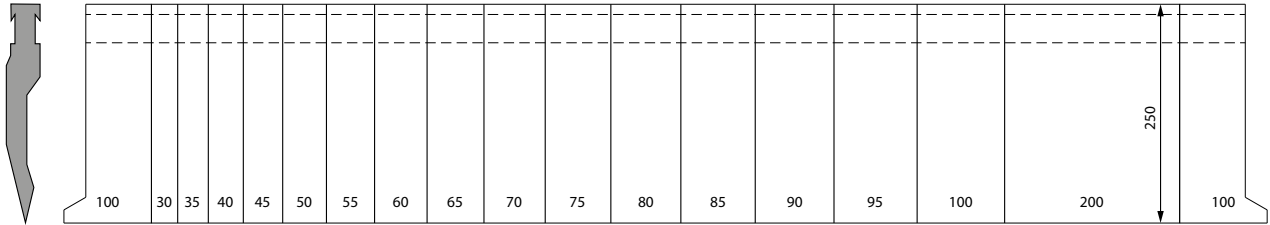

상부 툴	부품 번호
펀치 P2 RF-AC/85° H=250 L=1375 sect.	65208.0002.5000
펀치 P4 RF-AC/85° H=250 L=1375 sect.	65208.0004.5000
펀치 P5 RF-AC/30° H=250 L=1375 sect.	65208.0005.5000
펀치 P7 RF-AC/30° H=250 L=1375 sect.	65208.0007.5000

전체 분할을 구성하는 길이:

30 mm, 35 mm, 40 mm, 45 mm, 50 mm, 55 mm, 60 mm, 65 mm, 70 mm, 75 mm, 80 mm, 85 mm, 90 mm, 95 mm, 100 mm, 혼 세트 100 mm LH + RH

상부 툴	부품 번호
펀치 P11 RF-AC B=20 H=250 L=1175 sect.	65208.0011.5000

분할을 구성하는 길이:

30 mm, 35 mm, 40 mm, 45 mm, 50 mm, 55 mm, 60 mm, 65 mm, 70 mm, 75 mm, 80 mm, 85 mm, 90 mm, 95 mm, 100 mm, 200 mm

하부 툴	부품 번호
다이 인서트 V-Flat B40 L=1025 sect.	65208.0000.5000

분할을 구성하는 길이:

50 mm, 55 mm, 60 mm, 65 mm, 70 mm, 75 mm, 80 mm, 85 mm, 90 mm, 95 mm, 100 mm, 200 mm



50	55	60	65	70	75	80	85	90	95	100	200

하부 툴		부품 번호
다이 인서트 V6C/30°	L=1025 sect.	64208.0006.5000
다이 인서트 V8C/30°	L=1025 sect.	64208.0008.5000
다이 인서트 V10C/30°	L=1025 sect.	64208.0010.5000
다이 인서트 V12C/30°	L=1025 sect.	64208.0012.5000
다이 인서트 V16C/30°	L=1025 sect.	64208.0020.5000
다이 인서트 V20C/30°	L=1025 sect.	64208.0020.5000
다이 인서트 V24C/30°	L=1025 sect.	64208.0024.5000
다이 인서트 V32C/30°	L=1025 sect.	64208.0032.5000
다이 인서트 V40C/60°	L=1025 sect.	64208.0040.5000
다이 인서트 V50C/60°	L=1025 sect.	64208.0050.5000
다이 인서트 V60C/60°	L=1025 sect.	64208.0060.5000
다이 인서트 V80C/80°	L=1025 sect.	64208.0080.5000
다이 인서트 V100C/80°	L=1025 sect.	64208.0100.5000
다이 인서트 V120C/80°	L=1025 sect.	64208.0120.5000
다이 인서트 V6SC/30°	L=1025 sect.	64208.0006.5100
다이 인서트 V8SC/30°	L=1025 sect.	64208.0008.5100
다이 인서트 V10SC/30°	L=1025 sect.	64208.0010.5100
다이 인서트 V12SC/30°	L=1025 sect.	64208.0012.5100

전체 분할을 구성하는 길이:

50 mm, 55 mm, 60 mm, 65 mm, 70 mm, 75 mm, 80 mm, 85 mm, 90 mm, 95 mm, 100 mm, 200 mm

* 최대 V80 이하의 하부 툴은 XTC에 적용됨
최대 V120 이하의 하부 툴은 BC/MTC에 적용됨



분할

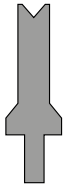

50	55	60	65	70	75	80	85	90	95	100	200

하부 툴	부품 번호
다이 인서트 V6C/30° H=100 L=1025 sect.	64208.0006.5031
다이 인서트 V8C/30° H=100 L=1025 sect.	64208.0008.5165
다이 인서트 V10C/30° H=100 L=1025 sect.	64208.0010.5031
다이 인서트 V12C/30° H=100 L=1025 sect.	64208.0012.5030
다이 인서트 V16C/30° H=100 L=1025 sect.	64208.0020.5040
다이 인서트 V20C/30° H=100 L=1025 sect.	64208.0020.5030
다이 인서트 V24C/30° H=100 L=1025 sect.	64208.0024.5031
다이 인서트 V32C/30° H=100 L=1025 sect.	64208.0032.5030
다이 인서트 V40C/60° H=100 L=1025 sect.	64208.0040.5030
다이 인서트 V50C/60° H=100 L=1025 sect.	64208.0050.5030
다이 인서트 V60C/60° H=100 L=1025 sect.	64208.0060.5030
다이 인서트 V80C/80° H=100 L=1025 sect.	64208.0080.5030

전체 분할을 구성하는 길이:

50 mm, 55 mm, 60 mm, 65 mm, 70 mm, 75 mm, 80 mm, 85 mm, 90 mm, 95 mm, 100 mm, 200 mm

* 최대 **V80** 이하의 하부 툴은 **XTC**에 적용됨
 최대 **V120** 이하의 하부 툴은 **BC/MTC**에 적용됨





상부 플랜지

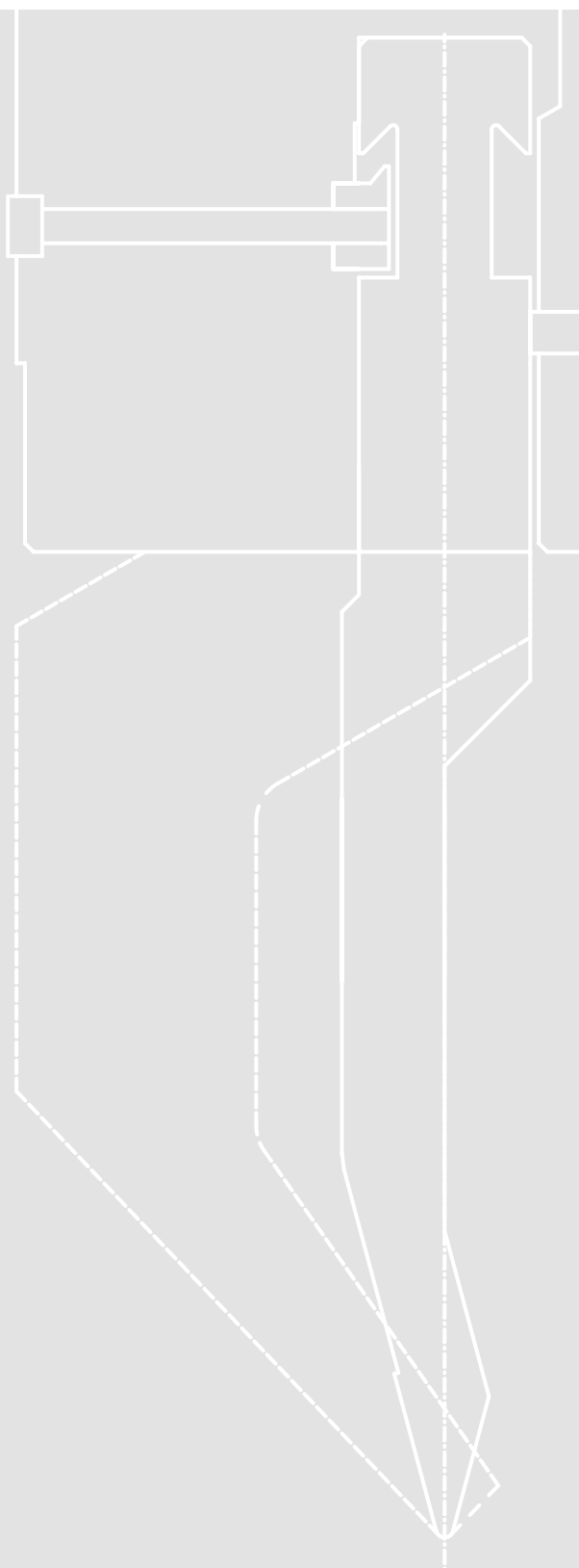

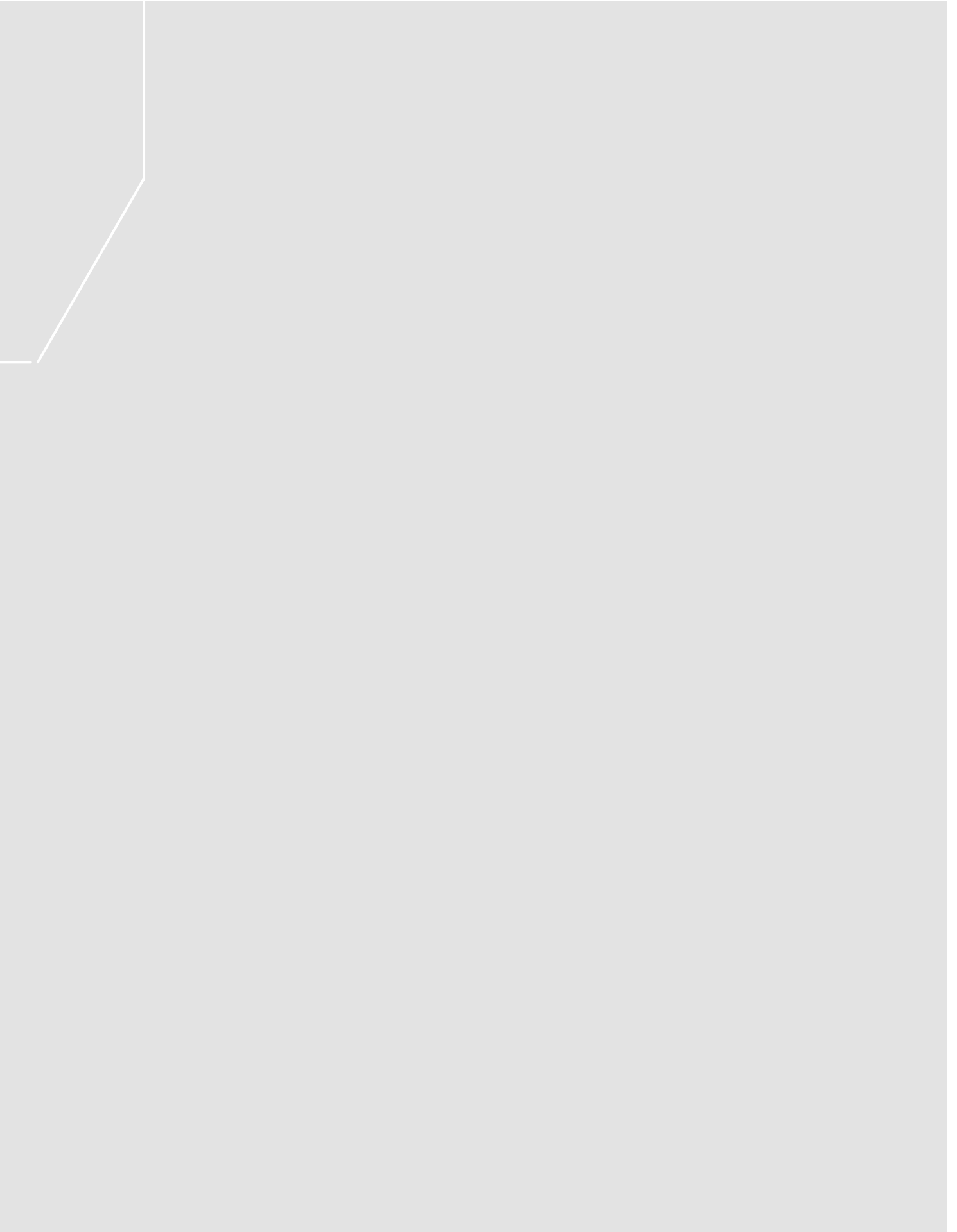



상부 틀 분할

흔 RF-AC

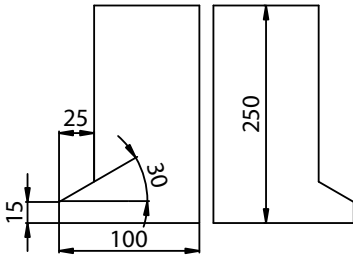

펀치 RF-AC L=1375 sect.

(30+35+40+45+50+60+65+70+75+80+85+90+95+100+200 +흔 좌+우)

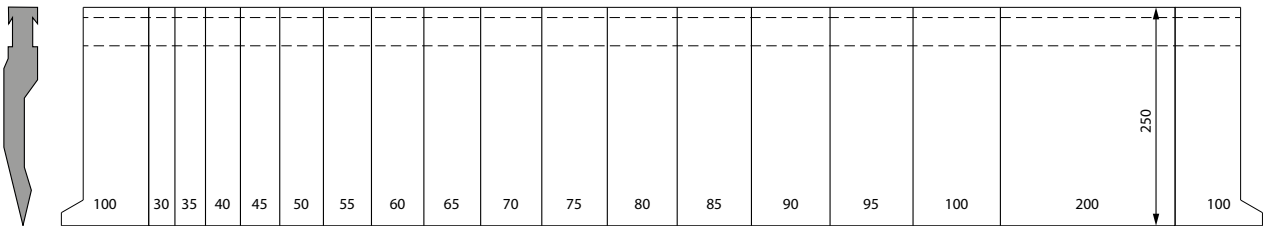

요청 시 특수 세분화 가능.

다른 반경의 전체 상부 틀은 요청 시 제공 가능합니다.

틀링 최대 무게:

그리퍼 XTC - 최대 15.0 kg

그리퍼 BC/MTC - 최대 25.0 kg



Modular Tool Changer



Bending Cell





P2 RF-AC/85° H250

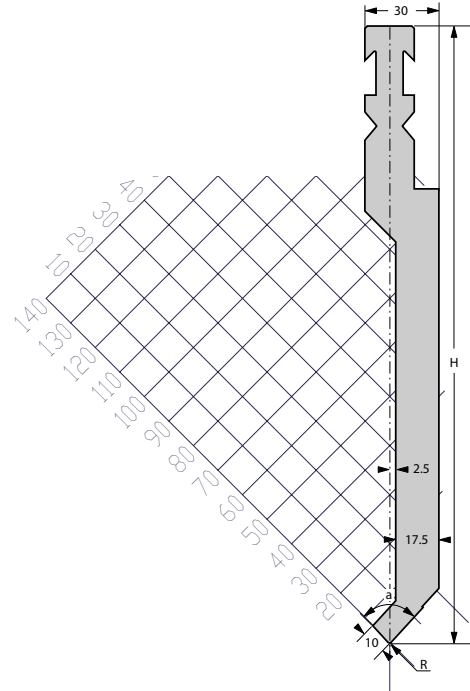

[R] 반경 (mm)*	1.0
노즈 (a) 각도	85°
[H] 높이 (mm)	250

*다른 반경은 요청 시 제공 가능

표준 길이	부품 번호
30 mm	65208.0002.5001
35 mm	65208.0002.5002
40 mm	65208.0002.5003
45 mm	65208.0002.5004
50 mm	65208.0002.5005
55 mm	65208.0002.5006
60 mm	65208.0002.5007
65 mm	65208.0002.5008
70 mm	65208.0002.5015
75 mm	65208.0002.5016
80 mm	65208.0002.5017

표준 길이	부품 번호
85 mm	65208.0002.5018
90 mm	65208.0002.5019
95 mm	65208.0002.5020
100 mm	65208.0002.5011
200 mm	65208.0002.5012
275 mm	65208.0002.5013
300 mm	65208.0002.5014
515 mm	65208.0002.5019
한 세트 LH + RH	65208.0002.7001
한 LH	65208.0002.7002
한 RH	65208.0002.7003



F max = 1000 kN/m



34.4 kg/m



98.0 mm



P4 RF-AC/85° H250

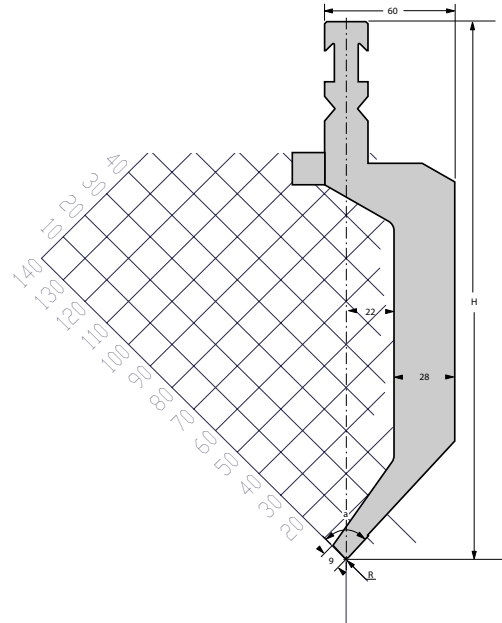

[R] 반경 (mm)*	1.5
노즈 (a) 각도	85°
[H] 높이 (mm)	250

*다른 반경은 요청 시 제공 가능

표준 길이	부품 번호
30 mm	65208.0004.5001
35 mm	65208.0004.5002
40 mm	65208.0004.5003
45 mm	65208.0004.5004
50 mm	65208.0004.5005
55 mm	65208.0004.5006
60 mm	65208.0004.5007
65 mm	65208.0004.5008
70 mm	65208.0004.5015
75 mm	65208.0004.5016
80 mm	65208.0004.5017

표준 길이	부품 번호
85 mm	65208.0004.5018
90 mm	65208.0004.5019
95 mm	65208.0004.5020
100 mm	65208.0004.5011
200 mm	65208.0004.5012
275 mm	65208.0004.5013
300 mm	65208.0004.5014
현 세트 LH + RH	65208.0004.7003
현 LH	65208.0004.7001
현 RH	65208.0004.7002



F max = 600 kN/m



48.3 kg/m



98.0 mm



P5 RF-AC/30° H250

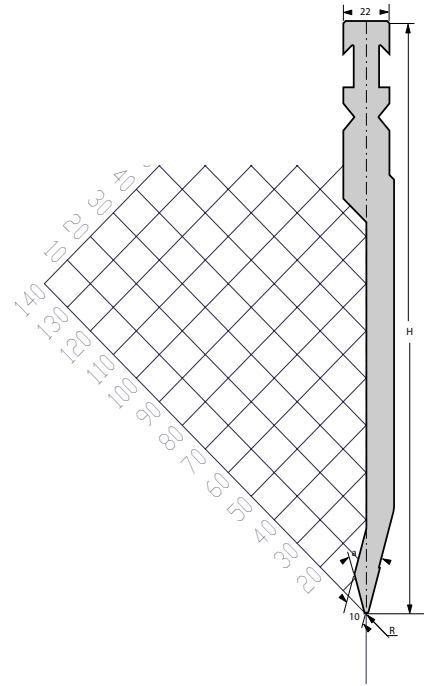

[R] 반경 (mm)*	1
노즈 (a) 각도	30°
[H] 높이 (mm)	250

*다른 반경은 요청 시 제공 가능

표준 길이	부품 번호
30 mm	65208.0005.5001
35 mm	65208.0005.5002
40 mm	65208.0005.5003
45 mm	65208.0005.5004
50 mm	65208.0005.5005
55 mm	65208.0005.5006
60 mm	65208.0005.5007
65 mm	65208.0005.5008
70 mm	65208.0005.5015
75 mm	65208.0005.5016
80 mm	65208.0005.5017

표준 길이	부품 번호
85 mm	65208.0005.5018
90 mm	65208.0005.5019
95 mm	65208.0005.5020
100 mm	65208.0005.5011
200 mm	65208.0005.5012
275 mm	65208.0005.5013
300 mm	65208.0005.5014
515 mm	65208.0005.5021
한 세트 LH + RH	65208.0005.7003
한 LH	65208.0005.7001
한 RH	65208.0005.7002



F max = 750 kN/m



26.0 kg/m



98.0 mm



P7 RF-AC/30° H250

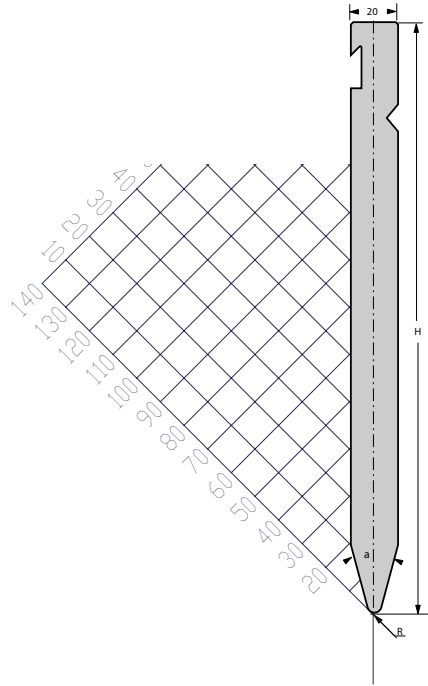

[R] 반경 (mm)*	3
노즈 (a) 각도	30°
[H] 높이 (mm)	250

*다른 반경은 요청 시 제공 가능

표준 길이	부품 번호
30 mm	65208.0007.5001
35 mm	65208.0007.5002
40 mm	65208.0007.5003
45 mm	65208.0007.5004
50 mm	65208.0007.5005
55 mm	65208.0007.5006
60 mm	65208.0007.5007
65 mm	65208.0007.5008
70 mm	65208.0007.5015
75 mm	65208.0007.5016
80 mm	65208.0007.5017

표준 길이	부품 번호
85 mm	65208.0007.5018
90 mm	65208.0007.5019
95 mm	65208.0007.5020
100 mm	65208.0007.5011
200 mm	65208.0007.5012
275 mm	65208.0007.5013
300 mm	65208.0007.5014
515 mm	65208.0007.5026
한 세트 LH + RH	65208.0007.7003
한 LH	65208.0007.7001
한 RH	65208.0007.7002



F max = 1400 kN/m



35.9 kg/m



98.0 mm



하부 금형

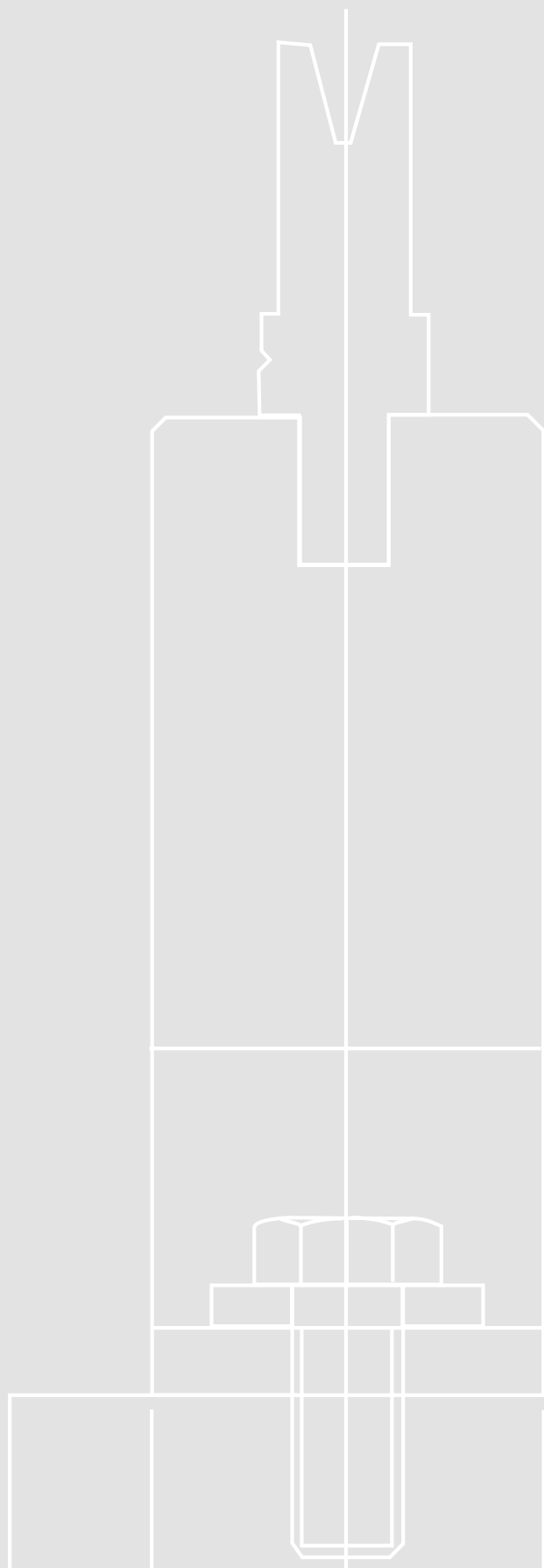





하단 테이블 옵션

유압식 톨 클램핑 방식의 테이블

T12

(옵션 Xpert 60 - 320 및
Xpert 250 - 1000)

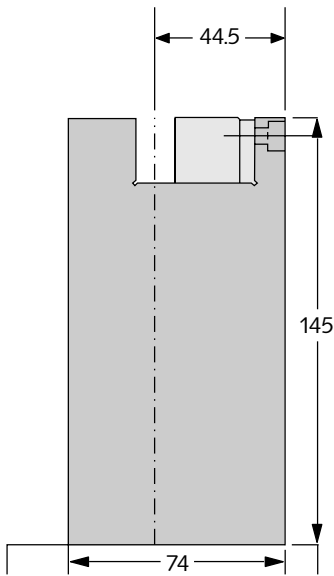

T13

(옵션 Xpert 60 - 320 및
Xpert 250 - 1000)

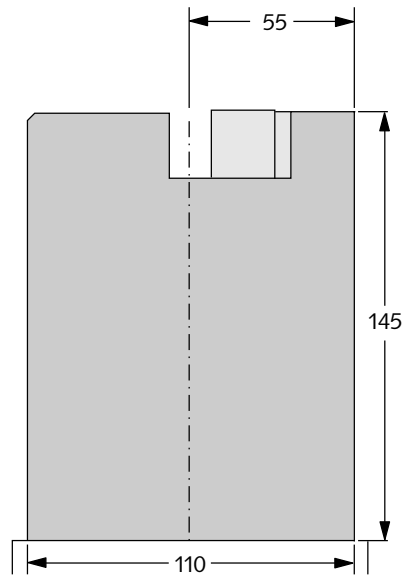



분할 다이

다이 인서트 VC L = 1025 sect.



50	55	60	65	70	75	80	85	90	95	100	200

요청 시 특수 세분화 가능.
그 외에도, 모든 낮은 틀은 반경, 다이 각도 및 높이가 수정되어 공급
될 수 있습니다(표준 사양 아님).



V6C/30° H55

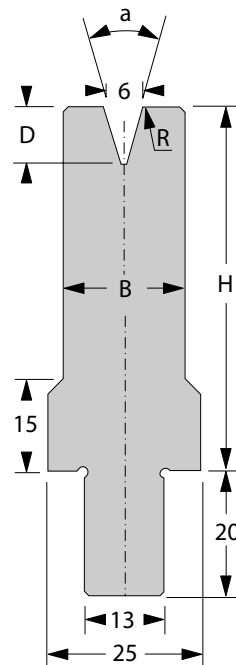

[R] 반경 (mm)*	0.75
[a] V - 각도	30°
[H] 높이 (mm)	55

[B] 폭 (mm)	20
[D] 깊이 (mm)	9.3

*다른 반경은 요청 시 제공 가능

표준 길이	부품 번호
50 mm	64208.0006.5001
55 mm	64208.0006.5002
60 mm	64208.0006.5003
65 mm	64208.0006.5004
70 mm	64208.0006.5005
75 mm	64208.0006.5006
80 mm	64208.0006.5007
85 mm	64208.0006.5008
90 mm	64208.0006.5009
95 mm	64208.0006.5010
100 mm	64208.0006.5011

표준 길이	부품 번호
200 mm	64208.0006.5012
275 mm	64208.0006.5013
300 mm	64208.0006.5014
515 mm	64208.0006.5015
1025 mm sect.	64208.0006.5000



F max 30° = 400 kN/m



10.9 kg/m



다이 인서트 13 mm



V6C/30° H100

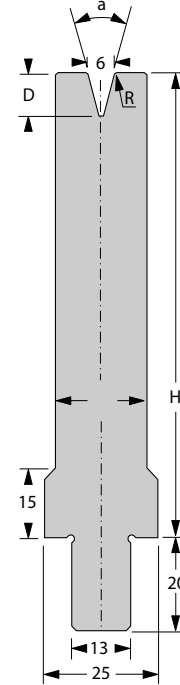

[R] 반경 (mm)*	0.75
[a] V - 각도	30°
[H] 높이 (mm)	100

[B] 폭 (mm)	20
[D] 깊이 (mm)	9.3

*다른 반경은 요청 시 제공 가능

표준 길이	부품 번호
50 mm	64208.0006.5016
55 mm	64208.0006.5017
60 mm	64208.0006.5018
65 mm	64208.0006.5019
70 mm	64208.0006.5020
75 mm	64208.0006.5021
80 mm	64208.0006.5022
85 mm	64208.0006.5023
90 mm	64208.0006.5024
95 mm	64208.0006.5025
100 mm	64208.0006.5026

표준 길이	부품 번호
200 mm	64208.0006.5027
275 mm	64208.0006.5028
300 mm	64208.0006.5029
515 mm	64208.0006.5030
1025 mm sect.	64208.0006.5031



F max 30° = 400 kN/m



18.0 kg/m



다이 인서트 13 mm



V8C/30° H55

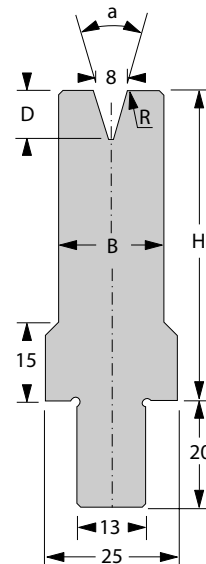

[R] 반경 (mm)*	1
[a] V - 각도	30°
[H] 높이 (mm)	55

[B] 폭 (mm)	20
[D] 깊이 (mm)	11.2

*다른 반경은 요청 시 제공 가능

표준 길이	부품 번호
50 mm	64208.0008.5001
55 mm	64208.0008.5002
60 mm	64208.0008.5003
65 mm	64208.0008.5004
70 mm	64208.0008.5005
75 mm	64208.0008.5006
80 mm	64208.0008.5007
85 mm	64208.0008.5008
90 mm	64208.0008.5009
95 mm	64208.0008.5010
100 mm	64208.0008.5011

표준 길이	부품 번호
200 mm	64208.0008.5012
275 mm	64208.0008.5013
300 mm	64208.0008.5014
515 mm	64208.0008.5015
1025 mm sect.	64208.0008.5000



$F_{max} 30^\circ = 400 \text{ kN/m}$



10.8 kg/m



다이 인서트 13 mm



V8C/30° H100

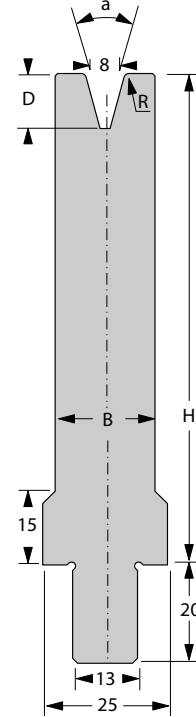

[R] 반경 (mm)*	1
[a] V - 각도	30°
[H] 높이 (mm)	100

[B] 폭 (mm)	20
[D] 깊이 (mm)	11.2

*다른 반경은 요청 시 제공 가능

표준 길이	부품 번호
50 mm	64208.0008.5016
55 mm	64208.0008.5017
60 mm	64208.0008.5018
65 mm	64208.0008.5019
70 mm	64208.0008.5020
75 mm	64208.0008.5021
80 mm	64208.0008.5022
85 mm	64208.0008.5023
90 mm	64208.0008.5024
95 mm	64208.0008.5025
100 mm	64208.0008.5026

표준 길이	부품 번호
200 mm	64208.0008.5027
275 mm	64208.0008.5028
300 mm	64208.0008.5029
515 mm	64208.0008.5030
1025 mm sect.	64208.0008.5165



F max 30° = 300 kN/m



17.8 kg/m



다이 인서트 13 mm



V10C/30° H55

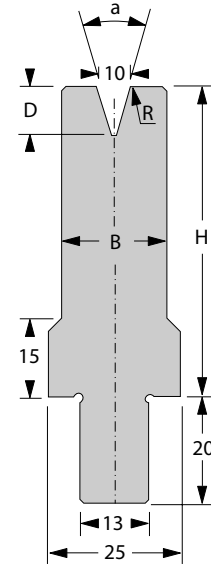

[R] 반경 (mm)*	1
[a] V - 각도	30°
[H] 높이 (mm)	55

[B] 폭 (mm)	20
[D] 깊이 (mm)	14.9

*다른 반경은 요청 시 제공 가능

표준 길이	부품 번호
50 mm	64208.0010.5001
55 mm	64208.0010.5002
60 mm	64208.0010.5003
65 mm	64208.0010.5004
70 mm	64208.0010.5005
75 mm	64208.0010.5006
80 mm	64208.0010.5007
85 mm	64208.0010.5008
90 mm	64208.0010.5009
95 mm	64208.0010.5010
100 mm	64208.0010.5011
200 mm	64208.0010.5012

표준 길이	부품 번호
275 mm	64208.0010.5013
300 mm	64208.0010.5014
515 mm	64208.0010.5015
1025 mm sect.	64208.0010.5000



F max 30° = 200 kN/m



10.6 kg/m



다이 인서트 13 mm



V10C/30° H100

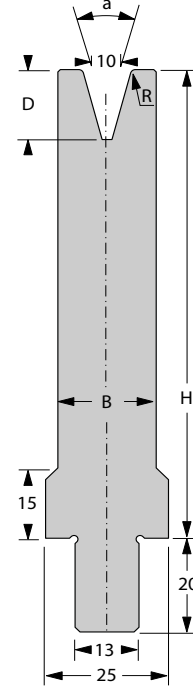

[R] 반경 (mm)*	1
[a] V - 각도	30°
[H] 높이 (mm)	100

[B] 폭 (mm)	20
[D] 깊이 (mm)	14.9

*다른 반경은 요청 시 제공 가능

표준 길이	부품 번호
50 mm	64208.0010.5016
55 mm	64208.0010.5017
60 mm	64208.0010.5018
65 mm	64208.0010.5019
70 mm	64208.0010.5020
75 mm	64208.0010.5021
80 mm	64208.0010.5022
85 mm	64208.0010.5023
90 mm	64208.0010.5024
95 mm	64208.0010.5025
100 mm	64208.0010.5026

표준 길이	부품 번호
200 mm	64208.0010.5027
275 mm	64208.0010.5028
300 mm	64208.0010.5029
515 mm	64208.0010.5030
1025 mm sect.	64208.0010.5031



F max 30° = 200 kN/m



17.6 kg/m



다이 인서트 13 mm



V12C/30° H55

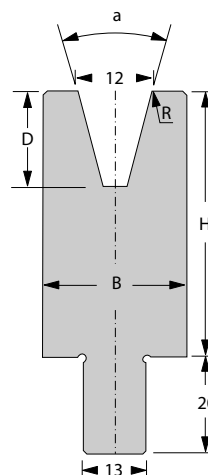

[R] 반경 (mm)*	1.5
[a] V - 각도	30°
[H] 높이 (mm)	55

[B] 폭 (mm)	25
[D] 깊이 (mm)	18.6

*다른 반경은 요청 시 제공 가능

표준 길이	부품 번호
50 mm	64208.0012.5001
55 mm	64208.0012.5002
60 mm	64208.0012.5003
65 mm	64208.0012.5004
70 mm	64208.0012.5005
75 mm	64208.0012.5006
80 mm	64208.0012.5007
85 mm	64208.0012.5008
90 mm	64208.0012.5009
95 mm	64208.0012.5010
100 mm	64208.0012.5011

표준 길이	부품 번호
200 mm	64208.0012.5012
275 mm	64208.0012.5013
300 mm	64208.0012.5014
515 mm	64208.0012.5015
1025 mm sect.	64208.0012.5000



F max 30° = 250 kN/m



11.8 kg/m



다이 인서트 13 mm



V12C/30° H100

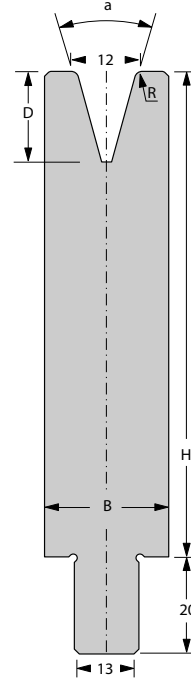

[R] 반경 (mm)*	1.5
[a] V - 각도	30°
[H] 높이 (mm)	100

[B] 폭 (mm)	25
[D] 깊이 (mm)	18.6

*다른 반경은 요청 시 제공 가능

표준 길이	부품 번호
50 mm	64208.0012.5017
55 mm	64208.0012.5018
60 mm	64208.0012.5019
65 mm	64208.0012.5020
70 mm	64208.0012.5021
75 mm	64208.0012.5022
80 mm	64208.0012.5023
85 mm	64208.0012.5024
90 mm	64208.0012.5025
95 mm	64208.0012.5026
100 mm	64208.0012.5027

표준 길이	부품 번호
200 mm	64208.0012.5028
275 mm	64208.0012.5029
300 mm	64208.0012.5016
515 mm	64208.0012.5031
1025 mm sect.	64208.0012.5030



F max 30° = 250 kN/m



20.6 kg/m



다이 인서트 13 mm



V16C/30° H55

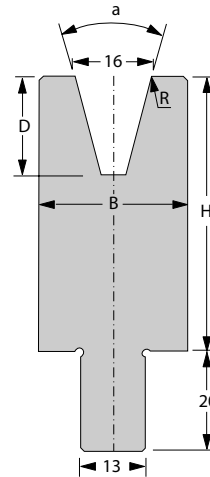

[R] 반경 (mm)*	2
[a] V - 각도	30°
[H] 높이 (mm)	55

[B] 폭 (mm)	30
[D] 깊이 (mm)	20.5

*다른 반경은 요청 시 제공 가능

표준 길이	부품 번호
50 mm	64208.0016.5001
55 mm	64208.0016.5002
60 mm	64208.0016.5003
65 mm	64208.0016.5004
70 mm	64208.0016.5005
75 mm	64208.0016.5006
80 mm	64208.0016.5007
85 mm	64208.0016.5008
90 mm	64208.0016.5009
95 mm	64208.0016.5010
100 mm	64208.0016.5011

표준 길이	부품 번호
200 mm	64208.0016.5012
275 mm	64208.0016.5013
300 mm	64208.0016.5014
515 mm	64208.0016.5015
1025 mm sect.	64208.0016.5000



F max 30° = 250 kN/m



13.3 kg/m



다이 인서트 13 mm



V16C/30° H100

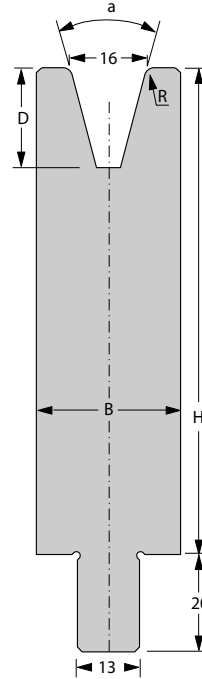

[R] 반경 (mm)*	2
[a] V - 각도	30°
[H] 높이 (mm)	100

[B] 폭 (mm)	30
[D] 깊이 (mm)	20.5

*다른 반경은 요청 시 제공 가능

표준 길이	부품 번호
50 mm	64208.0016.5016
55 mm	64208.0016.5017
60 mm	64208.0016.5018
65 mm	64208.0016.5019
70 mm	64208.0016.5020
75 mm	64208.0016.5021
80 mm	64208.0016.5022
85 mm	64208.0016.5023
90 mm	64208.0016.5024
95 mm	64208.0016.5025
100 mm	64208.0016.5026

표준 길이	부품 번호
200 mm	64208.0016.5027
275 mm	64208.0016.5028
300 mm	64208.0016.5029
515 mm	64208.0016.5030
1025 mm sect.	64208.0016.5040



F max 30° = 250 kN/m



23.9 kg/m



다이 인서트 13 mm



V20C/30° H55

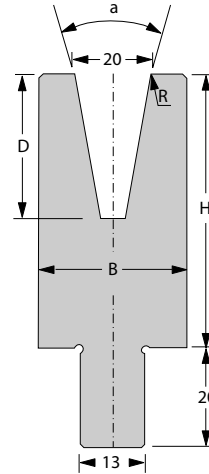

[R] 반경 (mm)*	2.5
[a] V - 각도	30°
[H] 높이 (mm)	55

[B] 폭 (mm)	30
[D] 깊이 (mm)	28

*다른 반경은 요청 시 제공 가능

표준 길이	부품 번호
50 mm	64208.0020.5001
55 mm	64208.0020.5002
60 mm	64208.0020.5003
65 mm	64208.0020.5004
70 mm	64208.0020.5005
75 mm	64208.0020.5006
80 mm	64208.0020.5007
85 mm	64208.0020.5008
90 mm	64208.0020.5009
95 mm	64208.0020.5010
100 mm	64208.0020.5011

표준 길이	부품 번호
200 mm	64208.0020.5012
275 mm	64208.0020.5013
300 mm	64208.0020.5014
515 mm	64208.0020.5015
1025 mm sect.	64208.0020.5000



F max 30° = 150 kN/m



12.2 kg/m



다이 인서트 13 mm



V20C/30° H100

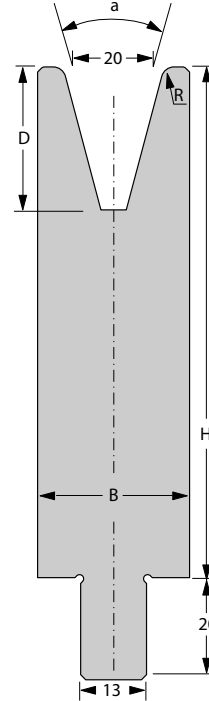

[R] 반경 (mm)*	2.5
[a] V - 각도	30°
[H] 높이 (mm)	100

[B] 폭 (mm)	30
[D] 깊이 (mm)	28

*다른 반경은 요청 시 제공 가능

표준 길이	부품 번호
50 mm	64208.0020.5017
55 mm	64208.0020.5018
60 mm	64208.0020.5019
65 mm	64208.0020.5020
70 mm	64208.0020.5021
75 mm	64208.0020.5022
80 mm	64208.0020.5023
85 mm	64208.0020.5024
90 mm	64208.0020.5025
95 mm	64208.0020.5026
100 mm	64208.0020.5027

표준 길이	부품 번호
200 mm	64208.0020.5028
275 mm	64208.0020.5029
300 mm	64208.0020.5016
515 mm	64208.0020.5031
1025 mm sect.	64208.0020.5030



F max 30° = 150 kN/m



22.8 kg/m



다이 인서트 13 mm



V24C/30° H55

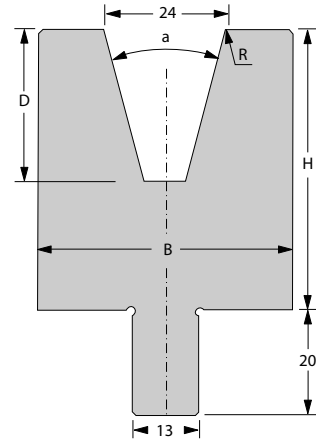

[R] 반경 (mm)*	3
[a] V - 각도	30°
[H] 높이 (mm)	55

[B] 폭 (mm)	40
[D] 깊이 (mm)	29.8

*다른 반경은 요청 시 제공 가능

표준 길이	부품 번호
50 mm	64208.0024.5001
55 mm	64208.0024.5002
60 mm	64208.0024.5003
65 mm	64208.0024.5004
70 mm	64208.0024.5005
75 mm	64208.0024.5006
80 mm	64208.0024.5007
85 mm	64208.0024.5008
90 mm	64208.0024.5009
95 mm	64208.0024.5010
100 mm	64208.0024.5011

표준 길이	부품 번호
200 mm	64208.0024.5012
275 mm	64208.0024.5013
300 mm	64208.0024.5014
515 mm	64208.0024.5015
1025 mm sect.	64208.0024.5000



F max 30° = 300 kN/m



15.5 kg/m



다이 인서트 13 mm



V24C/30° H100

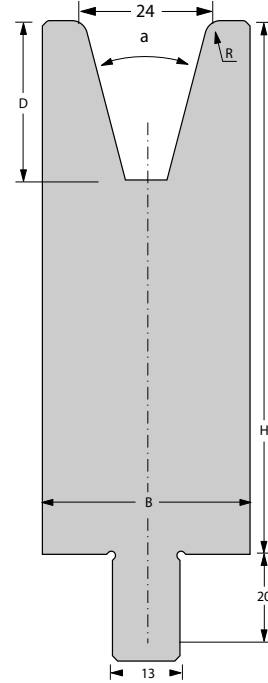

[R] 반경 (mm)*	3
[a] V - 각도	30°
[H] 높이 (mm)	100

[B] 폭 (mm)	40
[D] 깊이 (mm)	29.8

*다른 반경은 요청 시 제공 가능

표준 길이	부품 번호
50 mm	64208.0024.5016
55 mm	64208.0024.5017
60 mm	64208.0024.5018
65 mm	64208.0024.5019
70 mm	64208.0024.5020
75 mm	64208.0024.5021
80 mm	64208.0024.5022
85 mm	64208.0024.5023
90 mm	64208.0024.5024
95 mm	64208.0024.5025
100 mm	64208.0024.5026

표준 길이	부품 번호
200 mm	64208.0024.5027
275 mm	64208.0024.5028
300 mm	64208.0024.5029
515 mm	64208.0024.5030
1025 mm sect.	64208.0024.5031



F max 30° = 300 kN/m



29.6 kg/m



다이 인서트 13 mm



V32C/30° H55

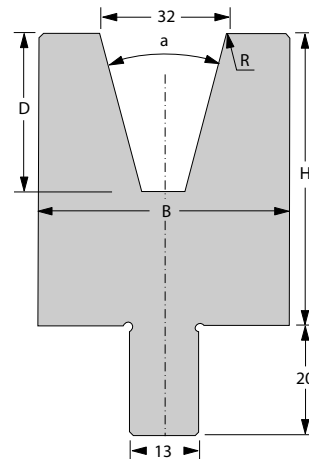

[R] 반경 (mm)*	4
[a] V - 각도	30°
[H] 높이 (mm)	55

[B] 폭 (mm)	48
[D] 깊이 (mm)	33.6

*다른 반경은 요청 시 제공 가능

표준 길이	부품 번호
50 mm	64208.0032.5001
55 mm	64208.0032.5002
60 mm	64208.0032.5003
65 mm	64208.0032.5004
70 mm	64208.0032.5005
75 mm	64208.0032.5006
80 mm	64208.0032.5007
85 mm	64208.0032.5008
90 mm	64208.0032.5009
95 mm	64208.0032.5010
100 mm	64208.0032.5011

표준 길이	부품 번호
200 mm	64208.0032.5012
275 mm	64208.0032.5013
300 mm	64208.0032.5014
515 mm	64208.0032.5015
1025 mm sect.	64208.0032.5000



F max 30° = 300 kN/m



16.7 kg/m



다이 인서트 13 mm



V32C/30° H100

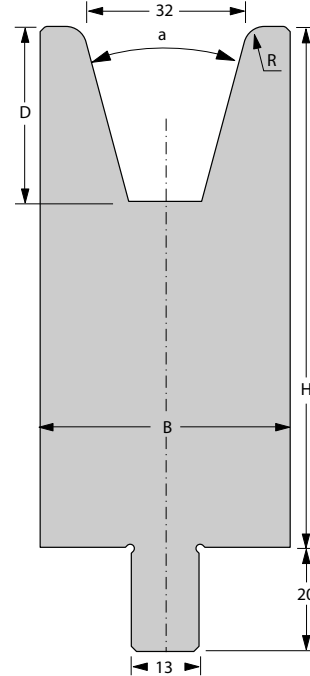

[R] 반경 (mm)*	4
[a] V-각도	30°
[H] 높이 (mm)	100

[B] 폭 (mm)	48
[D] 깊이 (mm)	33.6

*다른 반경은 요청 시 제공 가능

표준 길이	부품 번호
50 mm	64208.0032.5017
55 mm	64208.0032.5018
60 mm	64208.0032.5019
65 mm	64208.0032.5020
70 mm	64208.0032.5021
75 mm	64208.0032.5022
80 mm	64208.0032.5023
85 mm	64208.0032.5024
90 mm	64208.0032.5025
95 mm	64208.0032.5026
100 mm	64208.0032.5027

표준 길이	부품 번호
200 mm	64208.0032.5028
275 mm	64208.0032.5029
300 mm	64208.0032.5016
515 mm	64208.0032.5031
1025 mm sect.	64208.0032.5030



$F_{max} 30^\circ = 300 \text{ kN/m}$



33.7 kg/m



다이 인서트 13 mm



V40C/60° H55

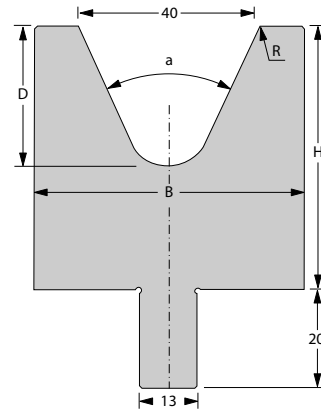
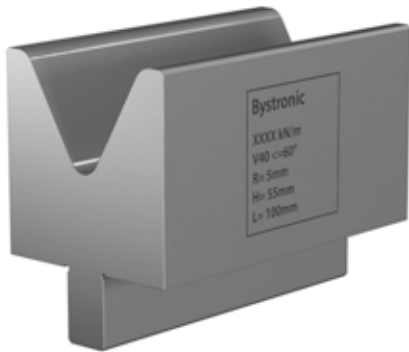

[R] 반경 (mm)*	5
[a] V - 각도	60°
[H] 높이 (mm)	55

[B] 폭 (mm)	55
[D] 깊이 (mm)	29.6

*다른 반경은 요청 시 제공 가능

표준 길이	부품 번호
50 mm	64208.0040.5001
55 mm	64208.0040.5002
60 mm	64208.0040.5003
65 mm	64208.0040.5004
70 mm	64208.0040.5005
75 mm	64208.0040.5006
80 mm	64208.0040.5007
85 mm	64208.0040.5008
90 mm	64208.0040.5009
95 mm	64208.0040.5010
100 mm	64208.0040.5011

표준 길이	부품 번호
200 mm	64208.0040.5012
275 mm	64208.0040.5013
300 mm	64208.0040.5014
515 mm	64208.0040.5015
1025 mm sect.	64208.0040.5000



F max 60° = 1800 kN/m



20.5 kg/m



다이 인서트 13 mm



V40C/60° H100

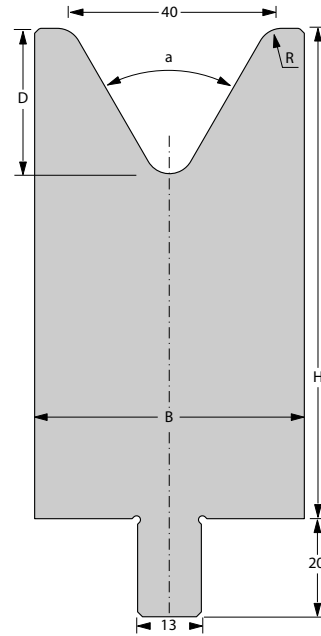

[R] 반경 (mm)*	5
[a] V - 각도	60°
[H] 높이 (mm)	100

[B] 폭 (mm)	55
[D] 깊이 (mm)	29.6

*다른 반경은 요청 시 제공 가능

표준 길이	부품 번호
50 mm	64208.0040.5017
55 mm	64208.0040.5018
60 mm	64208.0040.5019
65 mm	64208.0040.5020
70 mm	64208.0040.5021
75 mm	64208.0040.5022
80 mm	64208.0040.5023
85 mm	64208.0040.5024
90 mm	64208.0040.5025
95 mm	64208.0040.5026
100 mm	64208.0040.5027

표준 길이	부품 번호
200 mm	64208.0040.5028
275 mm	64208.0040.5029
300 mm	64208.0040.5016
515 mm	64208.0040.5031
1025 mm sect.	64208.0040.5030



$F_{max} 60^\circ = 1300 \text{ kN/m}$



39.9 kg/m



다이 인서트 13 mm



V50C/60° H55

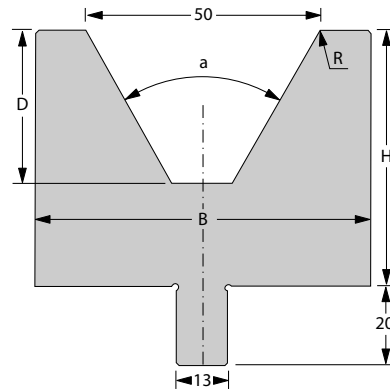

[R] 반경 (mm)*	5
[a] V - 각도	60°
[H] 높이 (mm)	55

[B] 폭 (mm)	70
[D] 깊이 (mm)	30.3

*다른 반경은 요청 시 제공 가능

표준 길이	부품 번호
50 mm	64208.0050.5001
55 mm	64208.0050.5002
60 mm	64208.0050.5003
65 mm	64208.0050.5004
70 mm	64208.0050.5005
75 mm	64208.0050.5006
80 mm	64208.0050.5007
85 mm	64208.0050.5008
90 mm	64208.0050.5009
95 mm	64208.0050.5010
100 mm	64208.0050.5011

표준 길이	부품 번호
200 mm	64208.0050.5012
275 mm	64208.0050.5013
300 mm	64208.0050.5014
515 mm	64208.0050.5015
1025 mm sect.	64208.0050.5000



F max 60° = 1200 kN/m



24.5 kg/m



다이 인서트 13 mm



V50C/60° H100

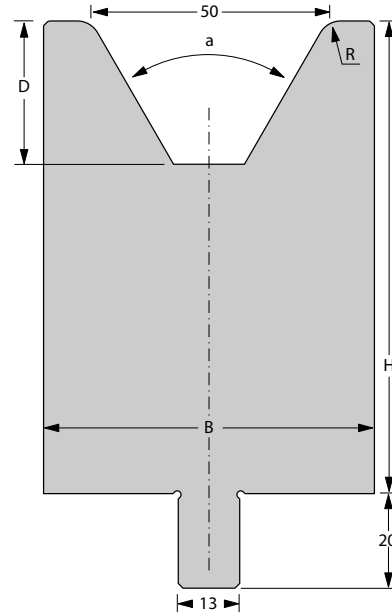

[R] 반경 (mm)*	5
[a] V - 각도	60°
[H] 높이 (mm)	100

[B] 폭 (mm)	70
[D] 깊이 (mm)	30.3

*다른 반경은 요청 시 제공 가능

표준 길이	부품 번호
50 mm	64208.0050.5016
55 mm	64208.0050.5017
60 mm	64208.0050.5018
65 mm	64208.0050.5019
70 mm	64208.0050.5020
75 mm	64208.0050.5021
80 mm	64208.0050.5022
85 mm	64208.0050.5023
90 mm	64208.0050.5024
95 mm	64208.0050.5025
100 mm	64208.0050.5026

표준 길이	부품 번호
200 mm	64208.0050.5027
275 mm	64208.0050.5028
300 mm	64208.0050.5029
515 mm	64208.0050.5031
1025 mm sect.	64208.0050.5030



F max 60° = 2000 kN/m



49.2 kg/m



다이 인서트 13 mm



V60C/60° H65

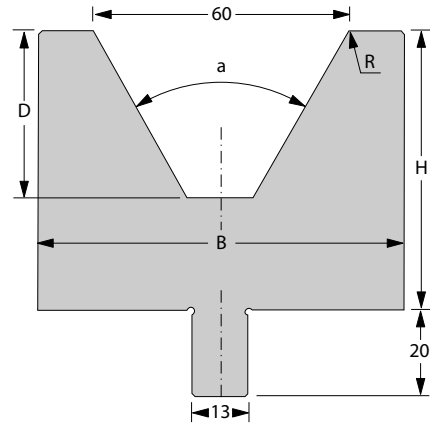
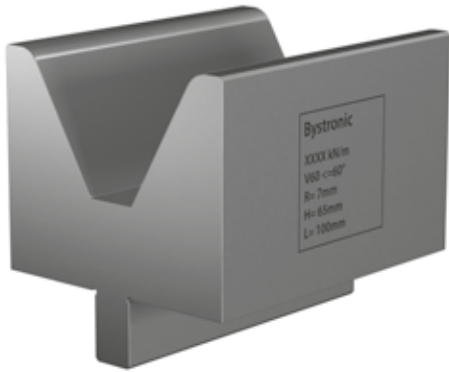

[R] 반경 (mm)*	7
[a] V - 각도	60°
[H] 높이 (mm)	65

[B] 폭 (mm)	80
[D] 깊이 (mm)	39

*다른 반경은 요청 시 제공 가능

표준 길이	부품 번호
50 mm	64208.0060.5001
55 mm	64208.0060.5002
60 mm	64208.0060.5003
65 mm	64208.0060.5004
70 mm	64208.0060.5005
75 mm	64208.0060.5006
80 mm	64208.0060.5007
85 mm	64208.0060.5008
90 mm	64208.0060.5009
95 mm	64208.0060.5010
100 mm	64208.0060.5011

표준 길이	부품 번호
200 mm	64208.0060.5012
275 mm	64208.0060.5013
300 mm	64208.0060.5014
515 mm	64208.0060.5031
1025 mm sect.	64208.0060.5000



F max 60° = 1600 kN/m



31.4 kg/m



다이 인서트 13 mm



V60C/60° H100

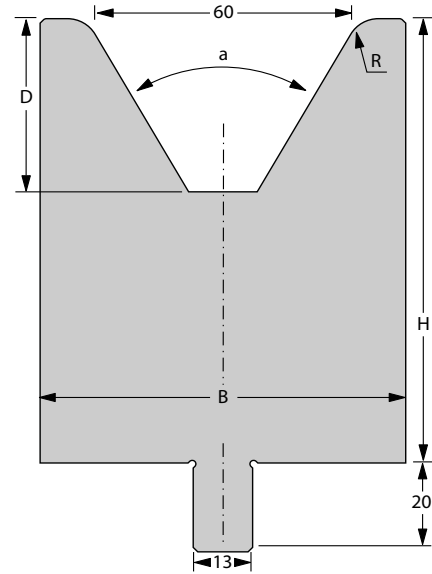

[R] 반경 (mm)*	7
[a] V - 각도	60°
[H] 높이 (mm)	100

[B] 폭 (mm)	80
[D] 깊이 (mm)	39

*다른 반경은 요청 시 제공 가능

표준 길이	부품 번호
50 mm	64208.0060.5016
55 mm	64208.0060.5017
60 mm	64208.0060.5018
65 mm	64208.0060.5019
70 mm	64208.0060.5020
75 mm	64208.0060.5021
80 mm	64208.0060.5022
85 mm	64208.0060.5023
90 mm	64208.0060.5024
95 mm	64208.0060.5025
100 mm	64208.0060.5026

표준 길이	부품 번호
200 mm	64208.0060.5015
275 mm	64208.0060.5027
300 mm	64208.0060.5028
1025 mm sect.	64208.0060.5030



F max 60° = 2000 kN/m



53.4 kg/m



다이 인서트 13 mm



V80C/80° H65

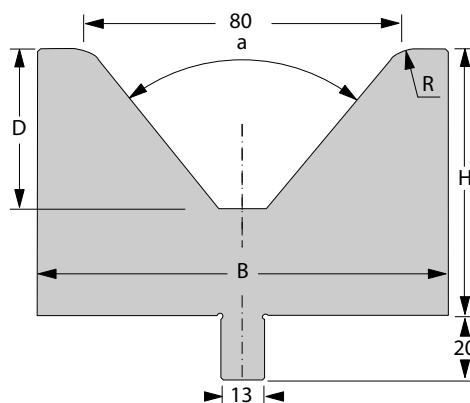
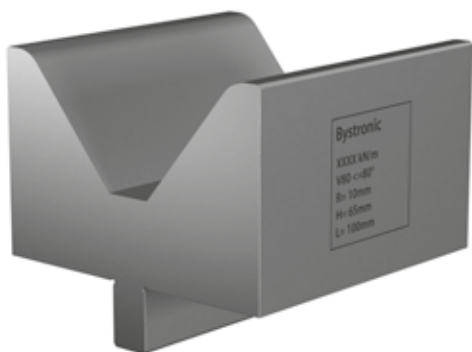

[R] 반경 (mm)*	10
[a] V - 각도	80°
[H] 높이 (mm)	65

[B] 폭 (mm)	100
[D] 깊이 (mm)	38.7

*다른 반경은 요청 시 제공 가능

표준 길이	부품 번호
50 mm	64208.0080.5001
55 mm	64208.0080.5002
60 mm	64208.0080.5003
65 mm	64208.0080.5004
70 mm	64208.0080.5005
75 mm	64208.0080.5006
80 mm	64208.0080.5007
85 mm	64208.0080.5008
90 mm	64208.0080.5009
95 mm	64208.0080.5010
100 mm	64208.0080.5011

표준 길이	부품 번호
200 mm	64208.0080.5012
275 mm	64208.0080.5013
300 mm	64208.0080.5014
515 mm	64208.0080.5029
1025 mm sect.	64208.0080.5000



F max 80° = 1400 kN/m



38.6 kg/m



다이 인서트 13 mm



V80C/80° H100

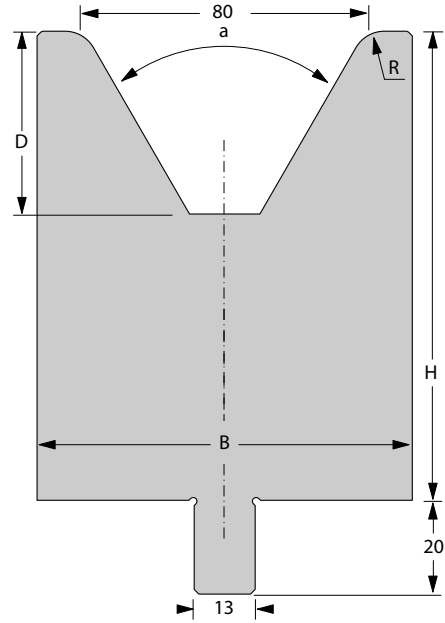

[R] 반경 (mm)*	10
[a] V - 각도	80°
[H] 높이 (mm)	100

[B] 폭 (mm)	100
[D] 깊이 (mm)	38.7

*다른 반경은 요청 시 제공 가능

표준 길이	부품 번호
50 mm	64208.0080.5015
55 mm	64208.0080.5016
60 mm	64208.0080.5017
65 mm	64208.0080.5018
70 mm	64208.0080.5019
75 mm	64208.0080.5020
80 mm	64208.0080.5021
85 mm	64208.0080.5022
90 mm	64208.0080.5023
95 mm	64208.0080.5024
100 mm	64208.0080.5025

표준 길이	부품 번호
200 mm	64208.0080.5026
275 mm	64208.0080.5027
300 mm	64208.0080.5028
1025 mm sect.	64208.0080.5030



F max 80° = 1400 kN/m



66.0 kg/m



다이 인서트 13 mm



V100C/80° H85

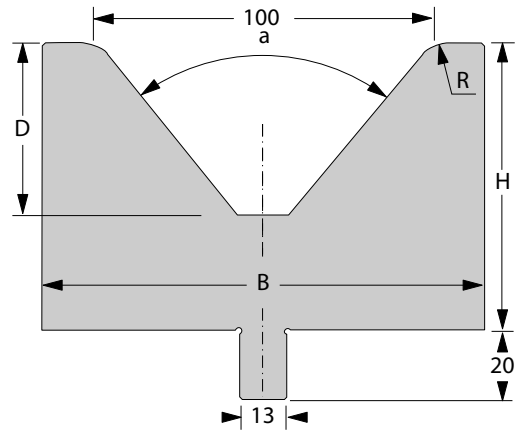
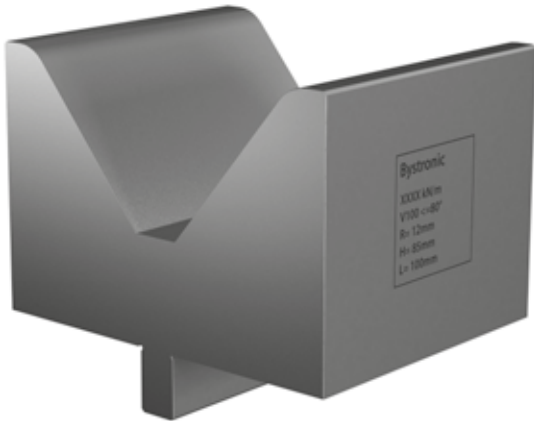

[R] 반경 (mm)*	12
[a] V - 각도	80°
[H] 높이 (mm)	85

[B] 폭 (mm)	125
[D] 깊이 (mm)	50.5

*다른 반경은 요청 시 제공 가능

표준 길이	부품 번호
50 mm	64208.0100.5001
55 mm	64208.0100.5002
60 mm	64208.0100.5003
65 mm	64208.0100.5004
70 mm	64208.0100.5005
75 mm	64208.0100.5006
80 mm	64208.0100.5007
85 mm	64208.0100.5008
90 mm	64208.0100.5009
95 mm	64208.0100.5010
100 mm	64208.0100.5011

표준 길이	부품 번호
200 mm	64208.0100.5012
275 mm	64208.0100.5013
300 mm	64208.0100.5014
1025 mm sect.	64208.0100.5000



F max 80° = 1800 kN/m



60.5 kg/m



다이 인서트 13 mm



V120C/80° H105

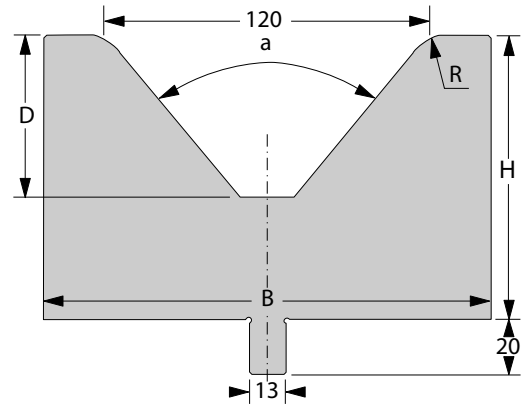
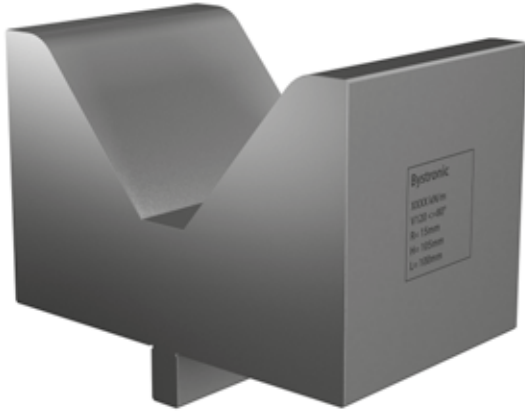

[R] 반경 (mm)*	15
[a] V - 각도	80°
[H] 높이 (mm)	105

[B] 폭 (mm)	160
[D] 깊이 (mm)	59.5

*다른 반경은 요청 시 제공 가능

표준 길이	부품 번호
50 mm	64208.0120.5001
55 mm	64208.0120.5002
60 mm	64208.0120.5003
65 mm	64208.0120.5004
70 mm	64208.0120.5005
75 mm	64208.0120.5006
80 mm	64208.0120.5007
85 mm	64208.0120.5008
90 mm	64208.0120.5009
95 mm	64208.0120.5010
100 mm	64208.0120.5011

표준 길이	부품 번호
200 mm	64208.0120.5012
275 mm	64208.0120.5013
300 mm	64208.0120.5014
1025 mm sect.	64208.0120.5000



F max 80° = 2000 kN/m



101.0 kg/m



다이 인서트 13 mm



V6SC/30° H55

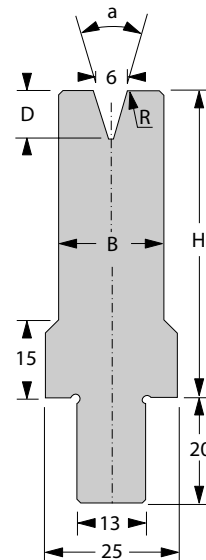

[R] 반경 (mm)*	0.75
[a] V - 각도	30°
[H] 높이 (mm)	55

[B] 폭 (mm)	12
[D] 깊이 (mm)	9.3

*다른 반경은 요청 시 제공 가능

표준 길이	부품 번호
50 mm	64208.0006.5101
55 mm	64208.0006.5102
60 mm	64208.0006.5103
65 mm	64208.0006.5104
70 mm	64208.0006.5105
75 mm	64208.0006.5106
80 mm	64208.0006.5107
85 mm	64208.0006.5108
90 mm	64208.0006.5109
95 mm	64208.0006.5110
100 mm	64208.0006.5111

표준 길이	부품 번호
200 mm	64208.0006.5112
275 mm	64208.0006.5113
300 mm	64208.0006.5114
515 mm	64208.0006.5115
1025 mm sect.	64208.0006.5100



F max 30° = 100 kN/m



8.1 kg/m



다이 인서트 13 mm



V6SC/30° H100

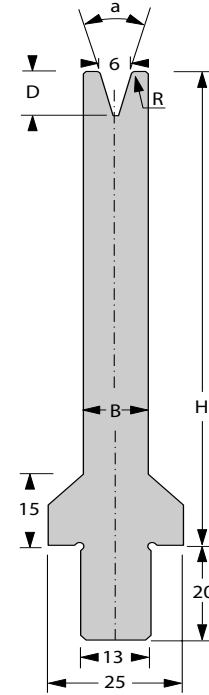

[R] 반경 (mm)*	0.75
[a] V- 각도	30°
[H] 높이 (mm)	100

[B] 폭 (mm)	12
[D] 깊이 (mm)	9.3

*다른 반경은 요청 시 제공 가능

표준 길이	부품 번호
50 mm	64208.0006.5151
55 mm	64208.0006.5152
60 mm	64208.0006.5153
65 mm	64208.0006.5154
70 mm	64208.0006.5155
75 mm	64208.0006.5156
80 mm	64208.0006.5157
85 mm	64208.0006.5158
90 mm	64208.0006.5159
95 mm	64208.0006.5160
100 mm	64208.0006.5161

표준 길이	부품 번호
200 mm	64208.0006.5162
275 mm	64208.0006.5163
300 mm	64208.0006.5164
515 mm	64208.0006.5165
1025 mm sect.	64208.0006.5150



F max 30° = 100 kN/m



12.3 kg/m



다이 인서트 13 mm



V8SC/30° H55

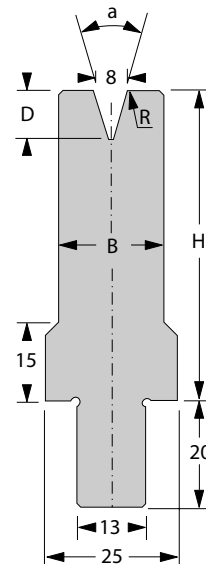

[R] 반경 (mm)*	1
[a] V - 각도	30°
[H] 높이 (mm)	55

[B] 폭 (mm)	14
[D] 깊이 (mm)	11.2

*다른 반경은 요청 시 제공 가능

표준 길이	부품 번호
50 mm	64208.0008.5102
55 mm	64208.0008.5103
60 mm	64208.0008.5104
65 mm	64208.0008.5105
70 mm	64208.0008.5106
75 mm	64208.0008.5107
80 mm	64208.0008.5108
85 mm	64208.0008.5109
90 mm	64208.0008.5110
95 mm	64208.0008.5111
100 mm	64208.0008.5112

표준 길이	부품 번호
200 mm	64208.0008.5113
275 mm	64208.0008.5114
300 mm	64208.0008.5115
515 mm	64208.0008.5116
1025 mm sect.	64208.0008.5100



F max 30° = 100 kN/m



8.7 kg/m



다이 인서트 13 mm



V8SC/30° H100

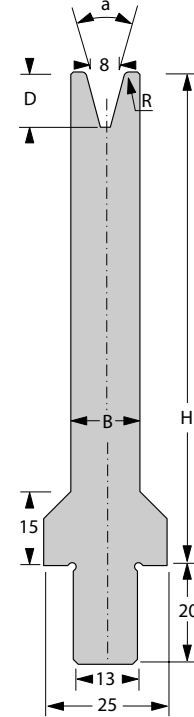

[R] 반경 (mm)*	1
[a] V - 각도	30°
[H] 높이 (mm)	100

[B] 폭 (mm)	14
[D] 깊이 (mm)	11.2

*다른 반경은 요청 시 제공 가능

표준 길이	부품 번호
50 mm	64208.0008.5151
55 mm	64208.0008.5152
60 mm	64208.0008.5153
65 mm	64208.0008.5154
70 mm	64208.0008.5155
75 mm	64208.0008.5156
80 mm	64208.0008.5157
85 mm	64208.0008.5158
90 mm	64208.0008.5159
95 mm	64208.0008.5160
100 mm	64208.0008.5161

표준 길이	부품 번호
200 mm	64208.0008.5162
275 mm	64208.0008.5163
300 mm	64208.0008.5164
515 mm	64208.0008.5166
1025 mm sect.	64208.0008.5150



$F_{max} 30^\circ = 1000 \text{ kN/m}$



13.7 kg/m



13 mm



V10SC/30° H55

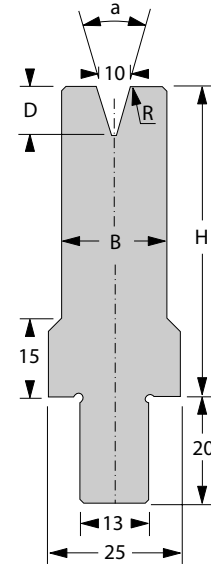

[R] 반경 (mm)*	1
[a] V - 각도	30°
[H] 높이 (mm)	55

[B] 폭 (mm)	16
[D] 깊이 (mm)	14.9

*다른 반경은 요청 시 제공 가능

표준 길이	부품 번호
50 mm	64208.0010.5101
55 mm	64208.0010.5102
60 mm	64208.0010.5103
65 mm	64208.0010.5104
70 mm	64208.0010.5105
75 mm	64208.0010.5106
80 mm	64208.0010.5107
85 mm	64208.0010.5108
90 mm	64208.0010.5109
95 mm	64208.0010.5110
100 mm	64208.0010.5111

표준 길이	부품 번호
200 mm	64208.0010.5112
275 mm	64208.0010.5113
300 mm	64208.0010.5114
515 mm	64208.0010.5115
1025 mm sect.	64208.0010.5100



F max 30° = 100 kN/m



9.1 kg/m



다이 인서트 13 mm



V10SC/30° H100

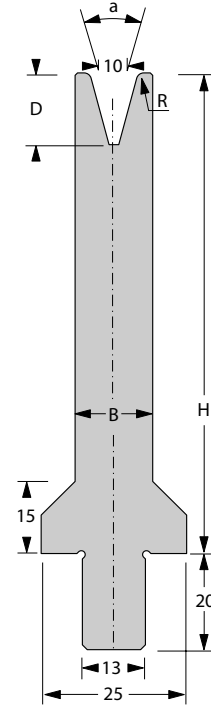

[R] 반경 (mm)*	1
[a] V - 각도	30°
[H] 높이 (mm)	100

[B] 폭 (mm)	16
[D] 깊이 (mm)	14.9

*다른 반경은 요청 시 제공 가능

표준 길이	부품 번호
50 mm	64208.0010.5117
55 mm	64208.0010.5118
60 mm	64208.0010.5119
65 mm	64208.0010.5120
70 mm	64208.0010.5121
75 mm	64208.0010.5122
80 mm	64208.0010.5123
85 mm	64208.0010.5124
90 mm	64208.0010.5125
95 mm	64208.0010.5126
100 mm	64208.0010.5127

표준 길이	부품 번호
200 mm	64208.0010.5128
275 mm	64208.0010.5129
300 mm	64208.0010.5130
515 mm	64208.0010.5131
1025 mm sect.	64208.0010.5116



F max 30° = 100 kN/m



14.7 kg/m



다이 인서트 13 mm



V12SC/30° H55

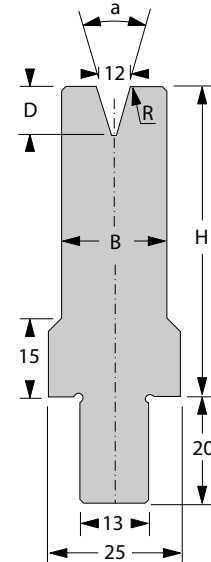

[R] 반경 (mm)*	1.5
[a] V - 각도	30°
[H] 높이 (mm)	55

[B] 폭 (mm)	18
[D] 깊이 (mm)	18.6

*다른 반경은 요청 시 제공 가능

표준 길이	부품 번호
50 mm	64208.0012.5101
55 mm	64208.0012.5102
60 mm	64208.0012.5103
65 mm	64208.0012.5104
70 mm	64208.0012.5105
75 mm	64208.0012.5106
80 mm	64208.0012.5107
85 mm	64208.0012.5108
90 mm	64208.0012.5109
95 mm	64208.0012.5110
100 mm	64208.0012.5111

표준 길이	부품 번호
200 mm	64208.0012.5112
275 mm	64208.0012.5113
300 mm	64208.0012.5114
515 mm	64208.0012.5115
1025 mm sect.	64208.0012.5100



F max 30° = 100 kN/m



9.5 kg/m



다이 인서트 13 mm



V12SC/30° H100

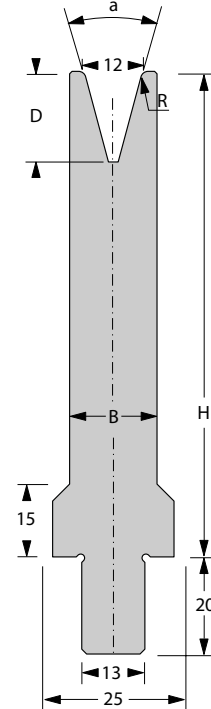

[R] 반경 (mm)*	1.5
[a] V - 각도	30°
[H] 높이 (mm)	100

[B] 폭 (mm)	18
[D] 깊이 (mm)	18.6

*다른 반경은 요청 시 제공 가능

표준 길이	부품 번호
50 mm	64208.0012.5117
55 mm	64208.0012.5118
60 mm	64208.0012.5119
65 mm	64208.0012.5120
70 mm	64208.0012.5121
75 mm	64208.0012.5122
80 mm	64208.0012.5123
85 mm	64208.0012.5124
90 mm	64208.0012.5125
95 mm	64208.0012.5126
100 mm	64208.0012.5127

표준 길이	부품 번호
200 mm	64208.0012.5128
275 mm	64208.0012.5129
300 mm	64208.0012.5130
515 mm	64208.0012.5131
1025 mm sect.	64208.0012.5116



F max 30° = 100 kN/m



15.9 kg/m



다이 인서트 13 mm



헤밍 금형 평탄화 공구

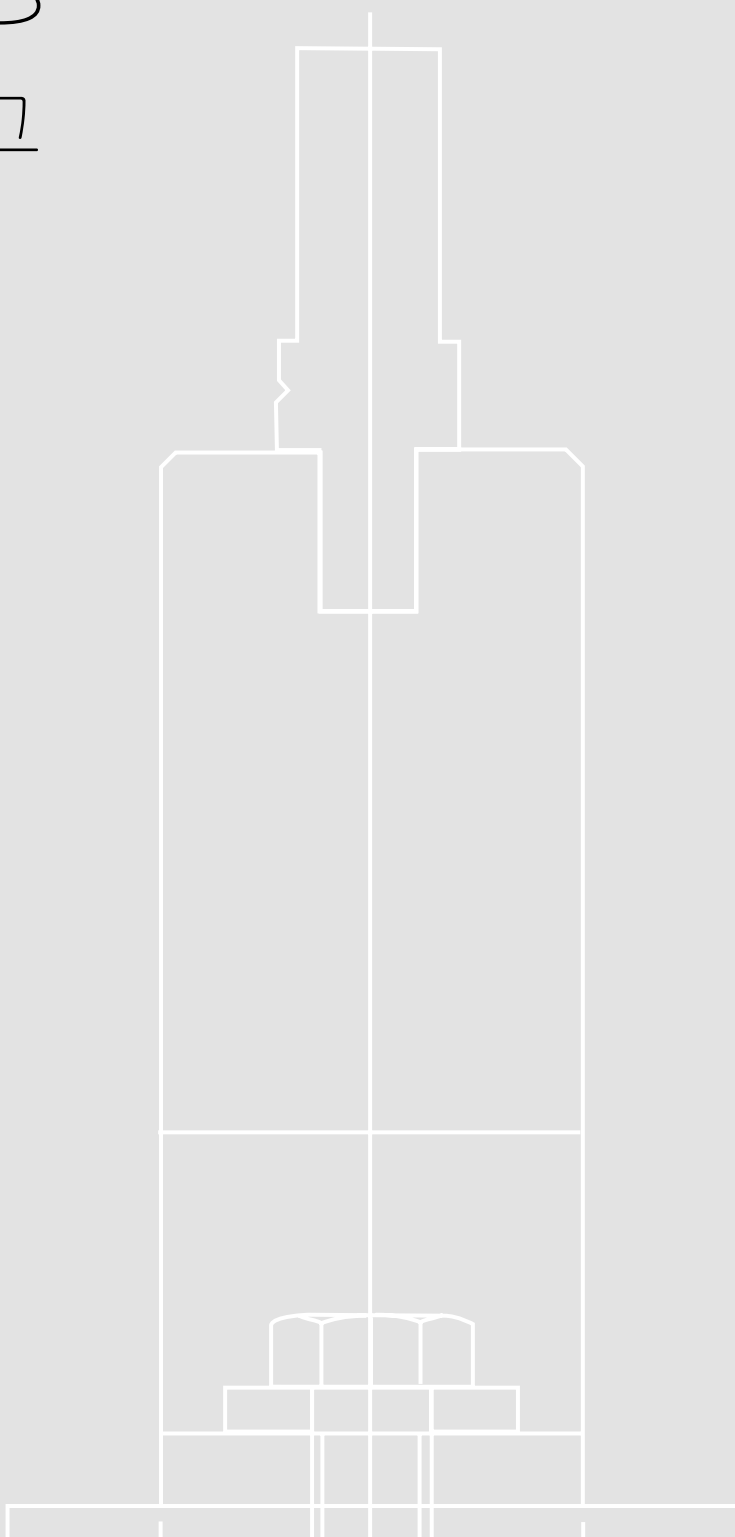





P11 RF-AC H250

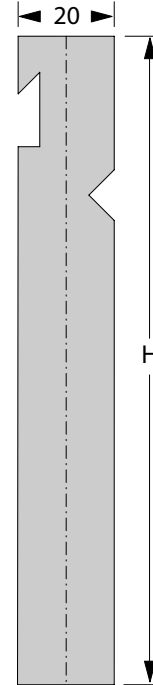

[B] 폭 (mm)	20
[H] 높이 (mm)	250

표준 길이	부품 번호
30 mm	65208.0011.5001
35 mm	65208.0011.5002
40 mm	65208.0011.5003
45 mm	65208.0011.5004
50 mm	65208.0011.5005
55 mm	65208.0011.5006
60 mm	65208.0011.5007
65 mm	65208.0011.5008
70 mm	65208.0011.5009
75 mm	65208.0011.5010
80 mm	65208.0011.5011

표준 길이	부품 번호
85 mm	65208.0011.5012
90 mm	65208.0011.5013
95 mm	65208.0011.5014
100 mm	65208.0011.5015
200 mm	65208.0011.5016
275 mm	65208.0011.5017
300 mm	65208.0011.5018
515 mm	65208.0011.5023
1175 mm sect.	65208.0011.5000



F max = 1400 kN/m



35.9 kg/m



98.0 mm



P900/8 RF-AC/30° H250

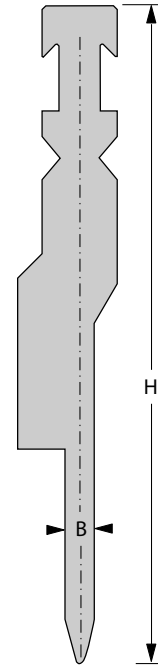

[B] 폭 (mm)	26.5
[H] 높이 (mm)	250

표준 길이	부품 번호
30 mm	65208.0900.5002
35 mm	65208.0900.5003
40 mm	65208.0900.5004
45 mm	65208.0900.5005
50 mm	65208.0900.5006
55 mm	65208.0900.5007
60 mm	65208.0900.5008
65 mm	65208.0900.5009
70 mm	65208.0900.5010
75 mm	65208.0900.5011
80 mm	65208.0900.5012

표준 길이	부품 번호
85 mm	65208.0900.5013
90 mm	65208.0900.5014
95 mm	65208.0900.5015
100 mm	65208.0900.5016
200 mm	65208.0900.5017
275 mm	65208.0900.5018
300 mm	65208.0900.5019
515 mm	65208.0900.5020
1175 mm sect.	65208.0900.5000



F max = 1000 kN/m



29.2 kg/m



P900/10 RF-AC/30° H250

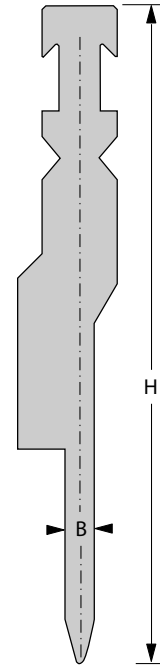

[B] 폭 (mm)	26.5
[H] 높이 (mm)	250

표준 길이	부품 번호
30 mm	65208.0900.5050
35 mm	65208.0900.5041
40 mm	65208.0900.5042
45 mm	65208.0900.5043
50 mm	65208.0900.5044
55 mm	65208.0900.5045
60 mm	65208.0900.5046
65 mm	65208.0900.5047
70 mm	65208.0900.5048
75 mm	65208.0900.5049
80 mm	65208.0900.5040

표준 길이	부품 번호
85 mm	65208.0900.5051
90 mm	65208.0900.5052
95 mm	65208.0900.5053
100 mm	65208.0900.5054
200 mm	65208.0900.5055
275 mm	65208.0900.5056
300 mm	65208.0900.5057
515 mm	65208.0900.5058
1175 mm sect.	65208.0900.5059



$F_{max} = 1000 \text{ kN/m}$



29.2 kg/m



P900/12 RF-AC/30° H250

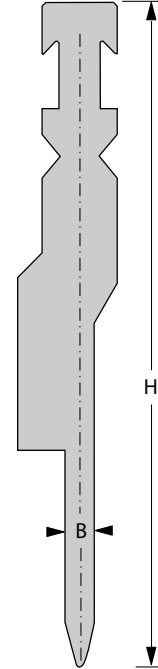

[B] 폭 (mm)	26.5
[H] 높이 (mm)	250

표준 길이	부품 번호
30 mm	65208.0900.5021
35 mm	65208.0900.5022
40 mm	65208.0900.5023
45 mm	65208.0900.5024
50 mm	65208.0900.5025
55 mm	65208.0900.5026
60 mm	65208.0900.5027
65 mm	65208.0900.5028
70 mm	65208.0900.5029
75 mm	65208.0900.5030
80 mm	65208.0900.5031

표준 길이	부품 번호
85 mm	65208.0900.5032
90 mm	65208.0900.5033
95 mm	65208.0900.5034
100 mm	65208.0900.5035
200 mm	65208.0900.5036
275 mm	65208.0900.5037
300 mm	65208.0900.5001
515 mm	65208.0900.5038
1175 mm sect.	65208.0900.5039



F max = 1000 kN/m



34.3 kg/m



V 플랫 B40

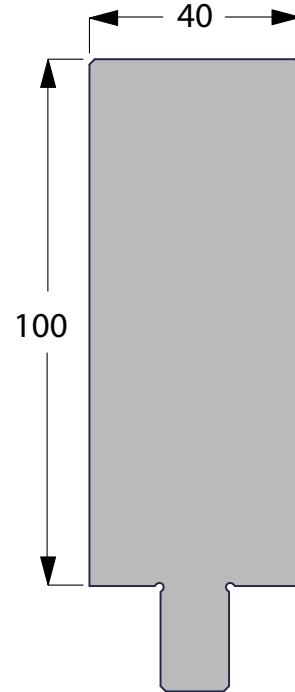

[B] 폭 (mm)	40
[H] 높이 (mm)	100

표준 길이	부품 번호
50 mm	64208.0000.5001
55 mm	64208.0000.5002
60 mm	64208.0000.5003
65 mm	64208.0000.5004
70 mm	64208.0000.5005
75 mm	64208.0000.5006
80 mm	64208.0000.5007
85 mm	64208.0000.5008
90 mm	64208.0000.5009
95 mm	64208.0000.5010
100 mm	64208.0000.5011

표준 길이	부품 번호
200 mm	64208.0000.5012
275 mm	64208.0000.5013
300 mm	64208.0000.5014
515 mm	64208.0000.5015
1025 mm sect.	64208.0000.5000



$F_{max} 30^\circ = 2000 \text{ kN/m}$



35.5 kg/m



다이 인서트 13 mm



V900/08C

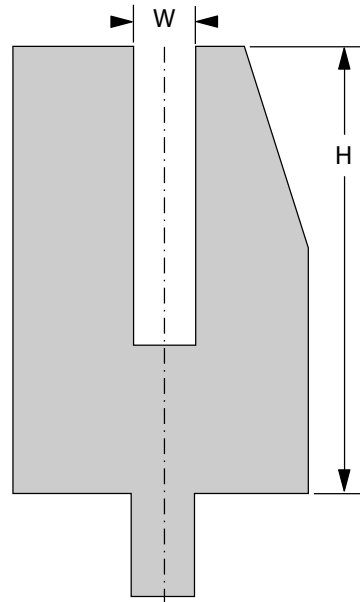

[B] 폭 (mm)	55
[H] 높이 (mm)	85

표준 길이	부품 번호
50 mm	64208.0900.5003
55 mm	64208.0900.5004
60 mm	64208.0900.5005
65 mm	64208.0900.5006
70 mm	64208.0900.5007
75 mm	64208.0900.5008
80 mm	64208.0900.5009
85 mm	64208.0900.5010
90 mm	64208.0900.5011
95 mm	64208.0900.5012
100 mm	64208.0900.5013

표준 길이	부품 번호
200 mm	64208.0900.5014
275 mm	64208.0900.5015
300 mm	64208.0900.5002
515 mm	64208.0900.5016
1025 mm sect.	64208.0900.5000



$F_{max} 30^\circ = 250 \text{ kN/m}$



35.5 kg/m



다이 인서트 13 mm



V900/10C

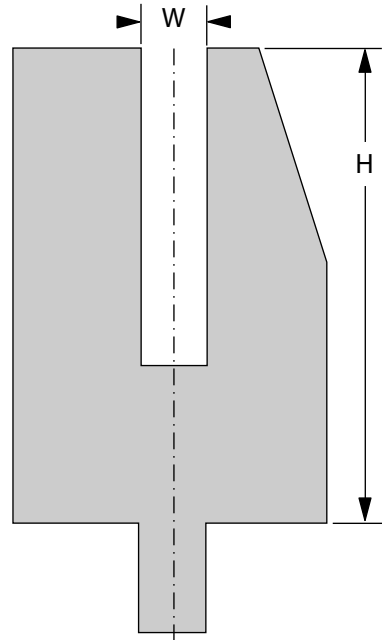

[B] 폭 (mm)	55
[H] 높이 (mm)	85

표준 길이	부품 번호
50 mm	64208.0900.5032
55 mm	64208.0900.5033
60 mm	64208.0900.5034
65 mm	64208.0900.5047
70 mm	64208.0900.5035
75 mm	64208.0900.5036
80 mm	64208.0900.5037
85 mm	64208.0900.5038
90 mm	64208.0900.5039
95 mm	64208.0900.5040
100 mm	64208.0900.5041

표준 길이	부품 번호
200 mm	64208.0900.5042
275 mm	64208.0900.5043
300 mm	64208.0900.5044
515 mm	64208.0900.5045
1025 mm sect.	64208.0900.5046



$F_{max} 30^\circ = 250 \text{ kN/m}$



32.0 kg/m



다이 인서트 13 mm



V900/12C

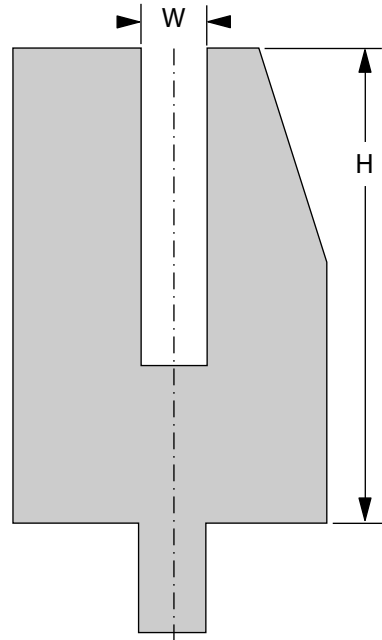

[B] 폭 (mm)	55
[H] 높이 (mm)	85

표준 길이	부품 번호
50 mm	64208.0900.5017
55 mm	64208.0900.5018
60 mm	64208.0900.5019
65 mm	64208.0900.5020
70 mm	64208.0900.5021
75 mm	64208.0900.5022
80 mm	64208.0900.5023
85 mm	64208.0900.5024
90 mm	64208.0900.5025
95 mm	64208.0900.5026
100 mm	64208.0900.5027

표준 길이	부품 번호
200 mm	64208.0900.5028
275 mm	64208.0900.5029
300 mm	64208.0900.5001
515 mm	64208.0900.5030
1025 mm sect.	64208.0900.5031



F max 30° = 250 kN/m



31.0 kg/m



다이 인서트 13 mm



전 세계 지사 연락처

Bystronic Laser AG
Industriestrasse 21
3362 Niederönz
Switzerland
Tel. +41 62 956 33 33
E-Mail info.laser@bystronic.com

Bystronic Australia Pty. Ltd.
4 Latchford Street
Cranbourne West VIC 3977
Australia
Tel.: +61 1300 975 761
E-Mail info.au@bystronic.com

Bystronic Austria GmbH
Schärdinger Straße 15
4061 Pasching
Austria
Tel. +43 7229 64411
E-Mail office.at@bystronic.com

Bystronic do Brasil Ltda.
Rua Parma 203
83413-587 – Colombo – PR
Brazil
Tel. +55 41 3666 9000
E-Mail bystronic.br@bystronic.com

Bystronic Canada Ltd
3330 Ridgeway Drive, Unit #11
Mississauga, ON L5L 5Z9
Canada
Tel: +1 905 890 2999
E-Mail sales.canada@bystronic.com

Bystronic(Tianjin) Laser Ltd.
No. 46 Xishi Road
Airport Industrial Park
300308 Tianjin
China
Tel: +86 22 5980 1888
E-Mail info.tj.cn@bystronic.com

Bystronic Czech Republic s.r.o.
Turanka 115/1222
627 00 Brno Slatina
Czech Republic
Tel. +420 532 123 314
E-Mail info.cz@bystronic.com

Bystronic Ibérica, S.A.
Avda. Tenerife nº 2
Edificio 1, Planta 3, Oficina D
28700 San Sebastián de los Reyes
(Madrid) España
Tel. +34 91 654 48 78
E-Mail sales.es@bystronic.com

Bystronic France SAS
Parc Technopolis
3, Avenue du Canada
91940 Les Ulis Cedex
France
Tel. +33 1 69 41 99 84
E-Mail info.fr@bystronic.com

Bystronic Maschinenbau GmbH
Mühlhäuser Strasse 3
99867 Gotha
Germany
Tel. +49 3621 38 30
E-Mail info.bending@bystronic.com

Bystronic Deutschland GmbH
Römerstrasse 14
71296 Heimsheim
Germany
Tel. +49 7033 46 99 0
E-Mail info.de@bystronic.com

Bystronic Magyarország Kft.
Budaörs Business Center
Puskás Tivadarút 5
2040 Budaörs
Hungary
Tel: +36 23 610 433
E-Mail info.hu@bystronic.com

Bystronic Laser India (Pvt) Ltd.
7C, Tadiwala Road
Next to Hotel Pancharatna
Pune 411 001
India
Tel: +91 20 67294800
E-Mail info.in@bystronic.com

Bystronic Italia SRL
Via del Lavoro, 30
20813 Bovisio-Masciago
Italia
Tel. +39 0362 5993 1
E-Mail sales.it@bystronic.com

Bystronic Japan, Ltd.
2-95-3 Inadaira Musashimurayama-shi
Tokyo 208-0023
Japan
Tel: +81 42 506 8271
E-Mail Cesar.Mujica@bystronic.com

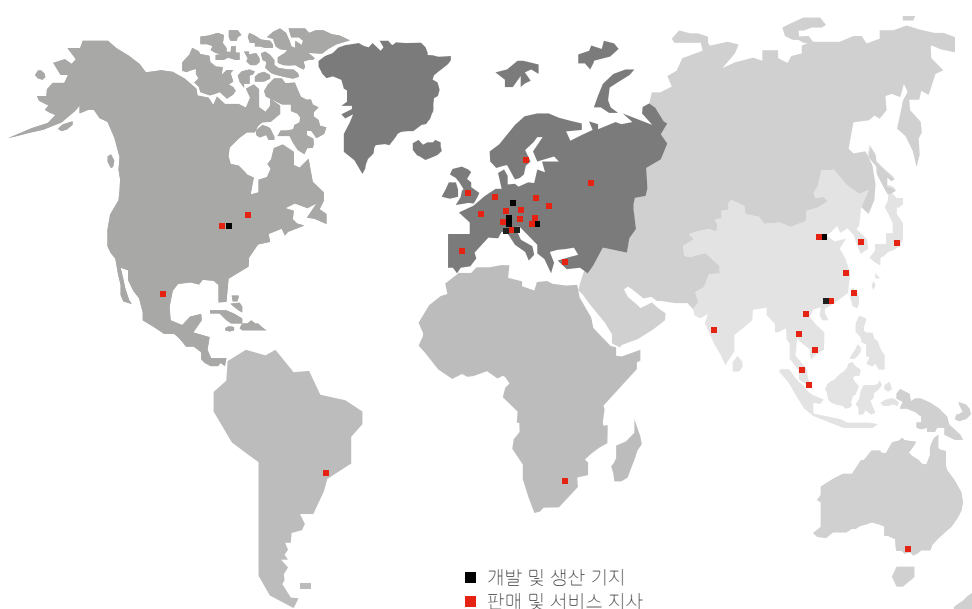



Bystronic Laser Pte. Ltd.
(Representative Office)
Level 8, MCT Tower, Sky Park,
One City, Jalan USJ 25/1
Subang Jaya
47650 Selangor
Malaysia
Tel: +60 3 8022 8268

Bystronic Mexico S.A. de C.V.
Helios 401 A, Parque Industrial FINSA
Apodaca
66600 Nuevo León
Mexico
Tel. +52 81 2133 7600
E-Mail sales.mexico@bystronic.com

Bystronic Benelux B.V.
Duurzaamheidsring 11
4231 EX Meerkerk
Nederland
Tel. +31 184 611 020
E-Mail sales.benelux@bystronic.com

Bystronic Korea, Ltd.
3F Bystronic Bldg,
32-18, LS-ro
91 Beon-gil, Dongan-gu Anyang-si
14119 Gyeonggi-do
Korea
Tel. +82 31 389 9800
E-Mail info.kr@bystronic.com

Bystronic Polska Sp. z o.o.
Ul. Sokolowska 47
PL-05-806 Sokolów
Poland
Tel. +48 22 331 37 70
E-Mail info.pl@bystronic.com

S.C. Bystronic Laser S.R.L.
Str. Poienelor no. 5
Industrial Pro Roman Park
500419 Brasov
Romania
Tel: +40 268 322 140
E-Mail info.ro@bystronic.com

Bystronic Laser
Zorge Street, 9A
Stroenie 2 (Building 2)
125252 Moscow
Russia
Tel: +7 495 984 71 44
E-Mail info.ru@bystronic.com

Bystronic Co., Ltd. (Shanghai)
Room 602, Part A,
No. 388 North Fu Quan Road
Changning District
Shanghai, 200335
Tel. +86 21 6082 9300
E-Mail info.sha.cn@bystronic.com

Bystronic Pte. Ltd.
Thye Hong Centre
2 Leng Kee Road #02-04
159086 Singapore
Tel. +65 6472 6300
E-Mail info.sg@bystronic.com

Bystronic Scandinavia AB
Metallvägen 30A
195 72 Rosersberg
Sverige
Tel: +46 (0)8 594 415 50
E-Mail Services.SE@bystronic.com

Bystronic Sales AG
Industriestrasse 21
3362 Niederönz
Switzerland
Tel. +41 62 956 37 83
E-Mail info.sales@bystronic.com

Bystronic International Laser Ltd.
No. 66, Wuquan Rd.,
Wugu Dist.,
New Taipei City 248
Taiwan (R.O.C)
Tel: +886 2 2299 2699
E-Mail hotline.tw@bystronic.com

Bystronic Lazer ve Su Isinlari
Makineleri Sanayi ve Ticaret Ltd. Sti.
Serifali Mevkii, Barbaros Caddesi
No: 66 K:1
34775 Ümraniye/Istanbul
Turkey
Tel: +90 216 464 6160
E-Mail info.tr@bystronic.com

LLC Bystronic Ukraine
59 Zhylyanskaya Street
Diplomat Hall, 2nd floor, Office 207
1033 Kyiv
Ukraine
Tel. +380 44 569 74 37
E-Mail info.cis@bystronic.com

Bystronic UK Ltd.
6 Wayside Business Park
Wilson's Lane
Coventry
Warwickshire CV6 6NY
United Kingdom
Tel: +44 (0)844 848 5850
E-Mail sales.uk@bystronic.com

Bystronic Inc.
2200 West Central Road
US-Hoffman Estates
IL 60192
USA
Tel. +1 847 214 0300
E-Mail sales.us@bystronic.com

Bystronic Vietnam Co. Ltd.
38/7 Truong Chinh Str.
Tan Thoi Nhat Ward
District 12
Hochiminh City
Vietnam
Tel: +84 28 3719 2278
E-Mail Anh Tuan.Ha@bystronic.com

