

Best choice.

Cutting. Bending. Automation.

Bystronic

Bystronic-gereedschappen Onze gereedschappen RF-AC

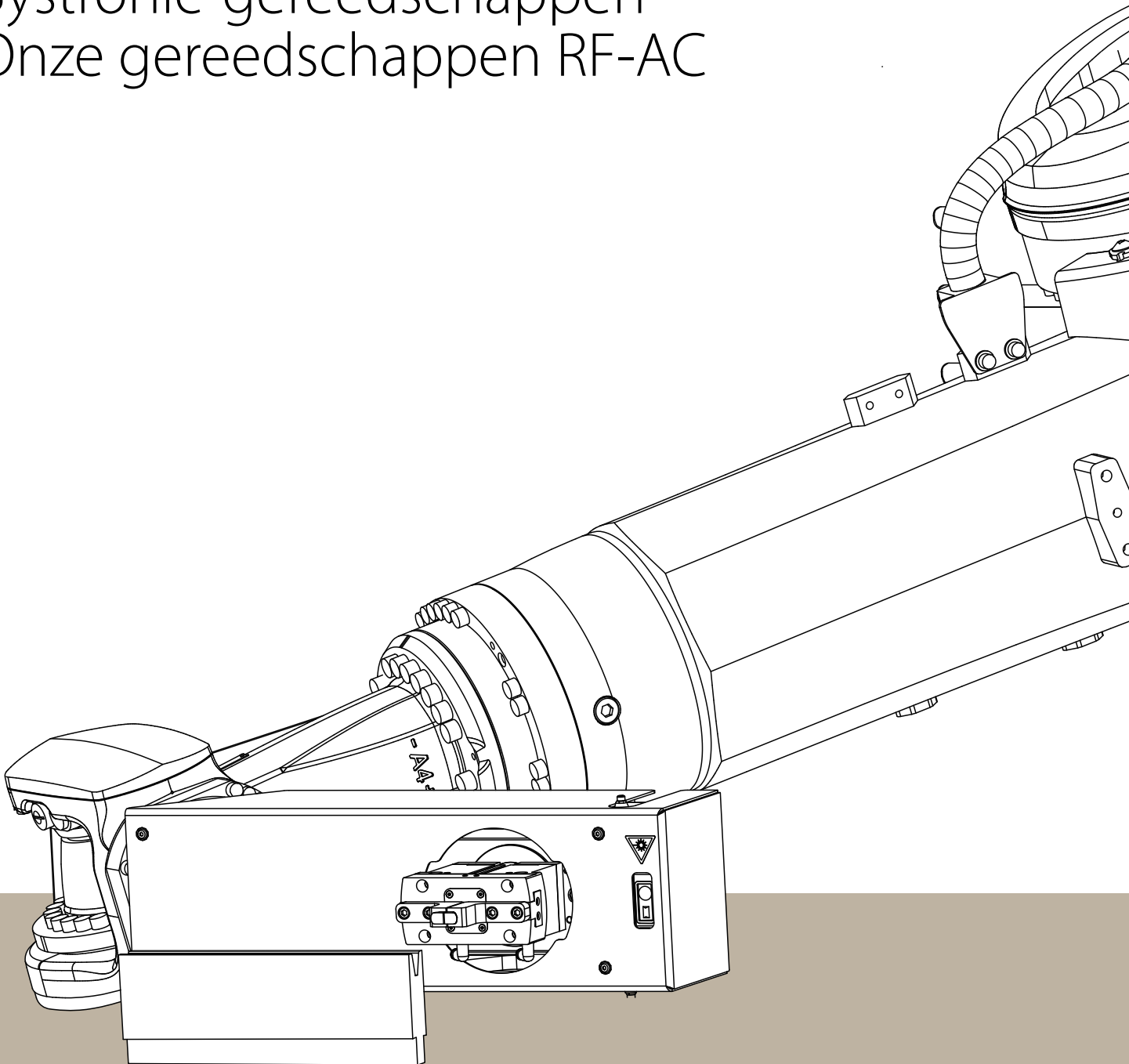



Inhoudsopgave

Principes3

Pictogrammen van deze catalogus.....3

Berekeningsprincipes voor luchtbuigen.....4

Hoe werkt het verwisselen
van gereedschap?.....8

Groeven.....9

Segmentaties.....10

Bovengereedschappen.....14

Segmenten van bovengereedschappen.....16

Ondergereedschappen.....22

Opties voor lagere tafel.....24

Matrijsdeling.....25

Toedrukgereedschappen.....60

Contactadressen wereldwijd.....70



Principes

Pictogrammen van deze catalogus



Hardheid: 58 - 62 HRC



Max. toegestane belasting



Max. doosdiepte



Gewicht



Gedraaid inzetten van de gereedschappen

De volgende werktuigen komen in deze catalogus aan de orde:

Xpert Tool Changer - XTC

Modular Tool Changer - MTC

Bending Cell - BC



Berekeningsprincipes voor luchtbuigen

Persluchttabel voor luchtbuigen

De gegevens in de tabel zijn gebaseerd op buigmateriaal met een treksterkte van $R_m = 420 \text{ N/mm}^2$ en 1 m buiglengte.

V	6	8	10	12	16	18	20	24	32	40	50	60	80
R	1	1.2	1.6	2	2.5	2.8	3	3.5	5	6	8	9.5	12
t	F	Buigkracht in kN/1 m buiglengte											
	a	Minimumflenslengte in mm											
0.5	25												
	4.3												
0.8	70	48											
	4.6	5.7											
1	115	80	60										
	5	6	7										
1.2		120	90	70									
		6	7.5	8.5									
1.5			150	120									
			8	9									
2.0				235	160	135	120	95					
				10	12	13	14.5	17					
2.5					265	225	200	155	110				
					12.5	14	15.5	17.5	23				
3.0							300	240	165	125			
							15.5	17.5	23.5	28			
4.0									315	235	180		
									25	29	35		
5.0									535	430	310	250	
									26	31	35.5	43	
6.0										610	450	360	
										32	36	44	
8.0											880	690	470
											40	46	57
10												800	
												60	
12												1200	
												62	
16													
18													
20													

Platen met walshuid verhogen de buigkrachten met een factor 1,05–1,1



100	120	130	140	150	160	180	190	200	230	260	290	320	V
15.5	19	21	23	24.5	26	28	30	32	36	40	45	50	R
F Buigkracht in kN/1 m buiglengte													t
a Minimumflenslengte in mm													
													0.5
													0.8
													1
													1.2
													1.5
													2.0
													2.5
													3.0
													4.0
													5.0
													6.0
360													8.0
71													10
600	470	430	390										12
71	85	92	100										16
900	710	650	580	550	500								18
73	86	92	100	105	115								20
	1400	1250	1150	1050	950	810	800	710	600				
	90	98	105	110	115	130	135	140	160				
			1480	1350	1250	1100	1000	950	800	700	600		
			105	110	120	130	135	140	160	180	205		
						1400	1300	1200	1000	900	850	700	
						135	140	145	165	180	205	225	

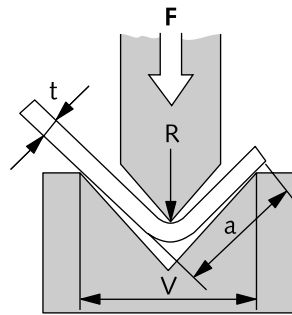

De interne radius R komt overeen met ongeveer 16% van de matrijsopening V.



Berekeningsprincipes voor luchtbuigen

Berekeningsformules

Aanbevolen matrijsopening V voor luchtbuigen

Materiaaldikte	t	0.5–2.5 mm	3–8 mm	9–10 mm	> 12 mm
Matrijsopening	V	6 × t	8 × t	10 × t	12 × t

Buigkracht voor

Aluminium	Rm = 300 N/mm ²	F = F (tabel) × 0.65
Zacht staal	Rm = 420 N/mm ²	F = F (tabel)
Roestvrij staal	Rm = 700 N/mm ²	F = F (tabel) × 1.6

Bepaling van de buigkracht voor luchtbuigen (richtwaarden)

$$F = \frac{R_m \times t^2}{V} \times \left(1 + \frac{4 \times t}{V}\right)$$

Omrekening: Rm = treksterkte in N/mm²

10 N = 1 kg

10 kN = 1 t

Omrekening voor minimale inwendige buigradii R

plaatdikte t	1	2	3	4	5	6	8	10	12	16	18	20
min. R	1	2	3	5	6	8	12	16	20	28	36	40



Treksterkte

Materiaal		Treksterkte	
Amerikaans	Europees	KPSI	N/mm ²
6061 aluminium	Alu 50	42	290
5052 aluminium	Alu 35	44	303
1010 zacht staal	DC01	53	366
A536-80 G 60-40-18	GGG-40	58	400
A 351 G CF 8	G-X 6CrNi 18 9	65	450
A 572 G50	S 355 MC	80	550
Domex 80	S 420 MC	80	550
A 36	S 235 JR	80	552
304 roestvrij	Inox V2A	85	586
316 roestvrij	Inox V4A	87	600
A 572 G 65	S 460 MC	95	655
Domex 100	S 500 MC	102	700
Domex 550	S 550 MC	110	760
Domex 600	S 600 MC	119	820
Weldox 700	Weldox 700	123	850
Domex 650	S 650 MC	128	880
Domex 700	S 700 MC	138	950
4140 laaggelegeerd	42 CrMo 4	145	1000
Weldox 900	Weldox 900	149	1030
Weldox 960	Weldox 960	154	1060
Hardox 400	Hardox 400	181	1250
Hardox 500	Hardox 500	225	1550

Vraag uw verantwoordelijke adviseur om advies als u materialen met een hogere sterkte wilt buigen.



Hoe werkt het verwisselen van gereedschap?

Slimme automatisering voor snel en nauwkeurig verwisselen van gereedschap

- Bespaar tijd en verhoog de buigkwaliteit dankzij het geautomatiseerd verwisselen van boven- en ondergereedschap
- Exacte en foutloze positionering van de gereedschapssets in het klemsysteem van de boven- en onderliggers, zelfs bij grote gereedschappen (max. V80/BC en MTC max. V120)
- Op elk gewenst moment eenvoudige uitbreiding van gereedschappen: slimme sensortechnologie detecteert automatisch nieuwe gereedschappen en integreert deze in het gereedschapsmagazijn
- Grotere verscheidenheid aan buigtoepassingen dankzij automatische rotatie van de bovengereedschappen
- Uitstekende ergonomie en compacte handling omdat alle gereedschappen gereedstaan in de machine
- Nauwkeurige en behoedzame verwerking van gebogen delen dankzij automatische reiniging van de buigtafel



*** Maximaal gereedschapsgewicht:**

Grijper XTC	- max. 15.0 kg
Grijper BC/MTC	- max. 25.0 kg



Groeven

Bovengereedschappen

Bovengereedschappen hebben groeven aan de achterzijde. Ponsen die asymmetrisch zijn (bijv. P4 en P5) hebben ook groeven aan de voorzijde.

Ponsen van het type P2, P3, P4, P5, P6, P7, P8, P9, P11 en P900 met een hoogte van 250 mm kunnen ook gehanteerd worden. Op aanvraag is ook gereedschap met een hoogte van 350 mm verkrijgbaar.

Segmentaties beginnen bij een lengte van 30 mm en zijn maximaal 515 mm lang.*

Ondergereedschappen

Ondergereedschappen hebben een groef aan de achterzijde. Om deze reden kan de robot de gereedschappen hanteren.

Insteekmatrijzen van V6 tot V120 zijn mogelijk.**

Segmentaties beginnen bij een lengte van 50 mm en zijn maximaal 515 mm lang.*

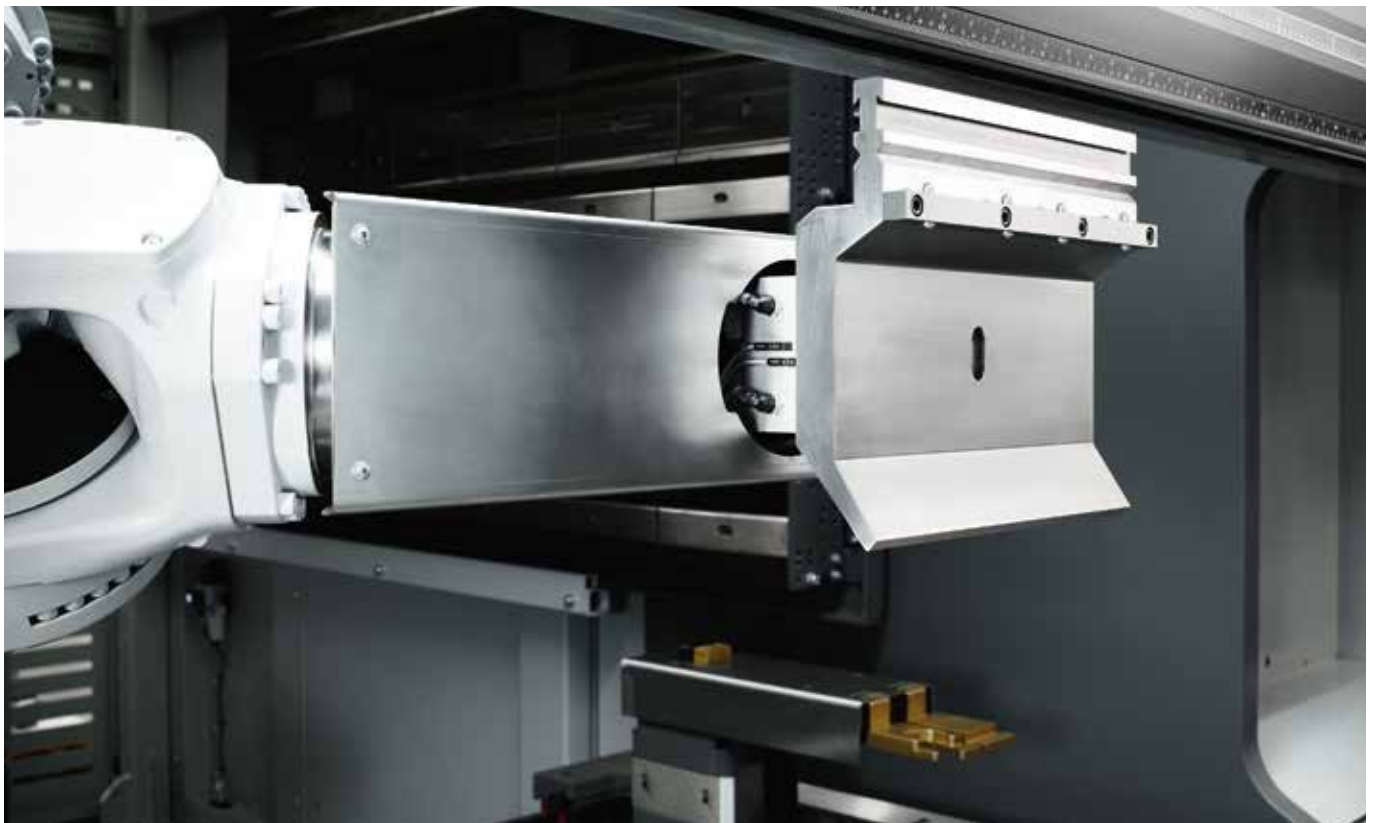

* Delen van meer dan 515 mm zijn verkrijgbaar op aanvraag of op BC/MTC

** Insteekmatrijzen tot en met V80 kunnen gehanteerd worden door XTC
Insteekmatrijzen tot en met V120 kunnen gehanteerd worden door BC/MTC



Segmentaties

Van toepassing op Xpert Tool Changer, MTC en BC

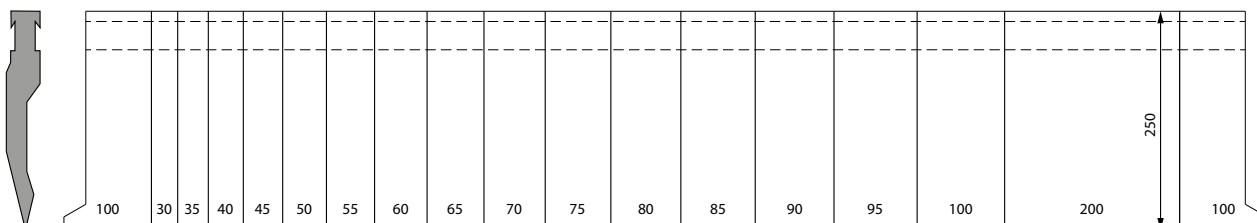

Bovengereedschappen	Onderdeelnummer
Pons P2 RF-AC/85° H=250 L=1375 sect.	65208.0002.5000
Pons P4 RF-AC/85° H=250 L=1375 sect.	65208.0004.5000
Pons P5 RF-AC/30° H=250 L=1375 sect.	65208.0005.5000
Pons P7 RF-AC/30° H=250 L=1375 sect.	65208.0007.5000

Alle segmentaties bestaan uit de volgende lengten:

30 mm, 35 mm, 40 mm, 45 mm, 50 mm, 55 mm, 60 mm, 65 mm, 70 mm, 75 mm, 80 mm, 85 mm, 90 mm, 95 mm, 100 mm, 200 mm, hoornset 100 mm links + rechts

Bovengereedschappen	Onderdeelnummer
Pons P11 RF-AC B=20 H=250 L=1175 sect.	65208.0011.5000

Segmentaties bestaan uit de volgende lengten:

30 mm, 35 mm, 40 mm, 45 mm, 50 mm, 55 mm, 60 mm, 65 mm, 70 mm, 75 mm, 80 mm, 85 mm, 90 mm, 95 mm, 100 mm, 200 mm

Ondergereedschappen	Onderdeelnummer
Insteekmatrijs V-Flat B40 L=1025 sect.	65208.0000.5000

Segmentaties bestaan uit de volgende lengten:

50 mm, 55 mm, 60 mm, 65 mm, 70 mm, 75 mm, 80 mm, 85 mm, 90 mm, 95 mm, 100 mm, 200 mm

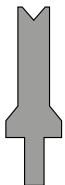

50	55	60	65	70	75	80	85	90	95	100	200

Ondergereedschappen	Onderdeelnummer
Insteekmatrijs V6C/30° L=1025 sect.	64208.0006.5000
Insteekmatrijs V8C/30° L=1025 sect.	64208.0008.5000
Insteekmatrijs V10C/30° L=1025 sect.	64208.0010.5000
Insteekmatrijs V12C/30° L=1025 sect.	64208.0012.5000
Insteekmatrijs V16C/30° L=1025 sect.	64208.0020.5000
Insteekmatrijs V20C/30° L=1025 sect.	64208.0020.5000
Insteekmatrijs V24C/30° L=1025 sect.	64208.0024.5000
Insteekmatrijs V32C/30° L=1025 sect.	64208.0032.5000
Insteekmatrijs V40C/60° L=1025 sect.	64208.0040.5000
Insteekmatrijs V50C/60° L=1025 sect.	64208.0050.5000
Insteekmatrijs V60C/60° L=1025 sect.	64208.0060.5000
Insteekmatrijs V80C/80° L=1025 sect.	64208.0080.5000
Insteekmatrijs V100C/80° L=1025 sect.	64208.0100.5000
Insteekmatrijs V120C/80° L=1025 sect.	64208.0120.5000
Insteekmatrijs V6SC/30° L=1025 sect.	64208.0006.5100
Insteekmatrijs V8SC/30° L=1025 sect.	64208.0008.5100
Insteekmatrijs V10SC/30° L=1025 sect.	64208.0010.5100
Insteekmatrijs V12SC/30° L=1025 sect.	64208.0012.5100

Alle segmentaties bestaan uit de volgende lengten:

50 mm, 55 mm, 60 mm, 65 mm, 70 mm, 75 mm, 80 mm, 85 mm, 90 mm, 95 mm,
100 mm, 200 mm

*** Ondergereedschappen tot en met V80 zijn van toepassing op XTC**
Ondergereedschappen tot en met V120 zijn van toepassing op de BC/MTC



Segmentaties

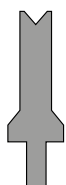

50	55	60	65	70	75	80	85	90	95	100	200

Ondergereedschappen	Onderdeelnummer
Insteekmatrijs V6C/30° H=100 L=1025 sect.	64208.0006.5031
Insteekmatrijs V8C/30° H=100 L=1025 sect.	64208.0008.5165
Insteekmatrijs V10C/30° H=100 L=1025 sect.	64208.0010.5031
Insteekmatrijs V12C/30° H=100 L=1025 sect.	64208.0012.5030
Insteekmatrijs V16C/30° H=100 L=1025 sect.	64208.0020.5040
Insteekmatrijs V20C/30° H=100 L=1025 sect.	64208.0020.5030
Insteekmatrijs V24C/30° H=100 L=1025 sect.	64208.0024.5031
Insteekmatrijs V32C/30° H=100 L=1025 sect.	64208.0032.5030
Insteekmatrijs V40C/60° H=100 L=1025 sect.	64208.0040.5030
Insteekmatrijs V50C/60° H=100 L=1025 sect.	64208.0050.5030
Insteekmatrijs V60C/60° H=100 L=1025 sect.	64208.0060.5030
Insteekmatrijs V80C/80° H=100 L=1025 sect.	64208.0080.5030

Alle segmentaties bestaan uit de volgende lengten:

50 mm, 55 mm, 60 mm, 65 mm, 70 mm, 75 mm, 80 mm, 85 mm, 90 mm, 95 mm,
100 mm, 200 mm

*** Ondergereedschappen tot en met V80 zijn van toepassing op XTC**
Ondergereedschappen tot en met V120 zijn van toepassing op de BC/MTC





Bovengereedschappen

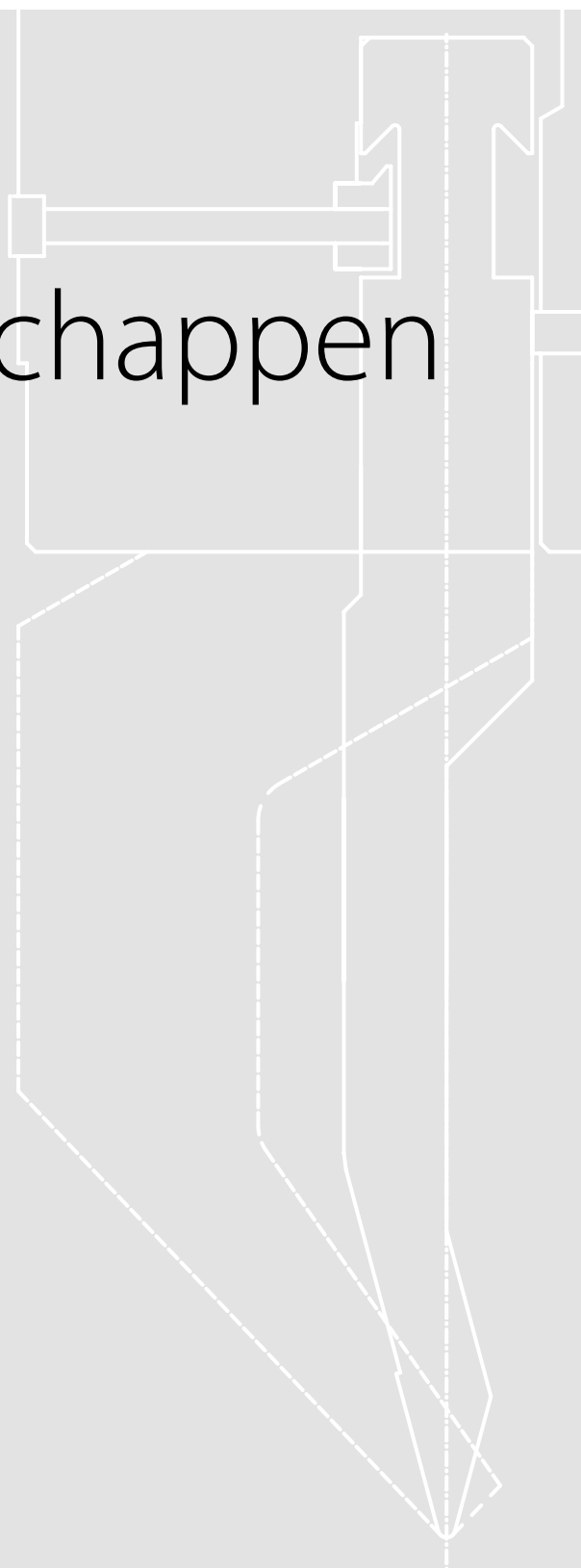

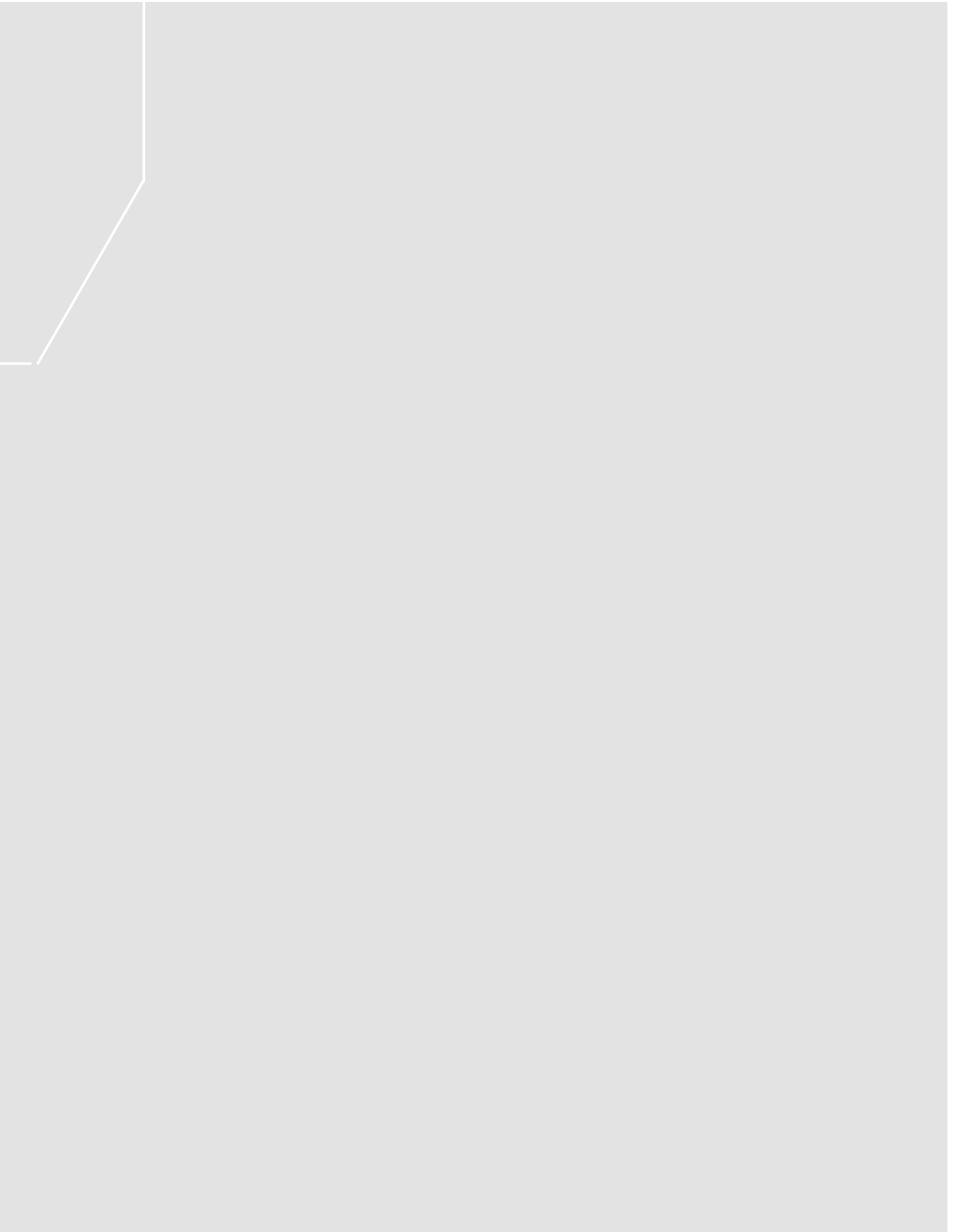



Segmenten van bovengereedschappen

Hoorns RF-AC

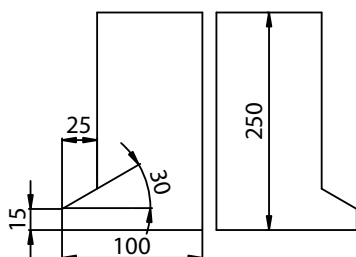

Pons RF-AC L = 1375 sect.

(30+35+40+45+50+60+65+70+75+80+85+90+95+100+200 +hoorns l+r)

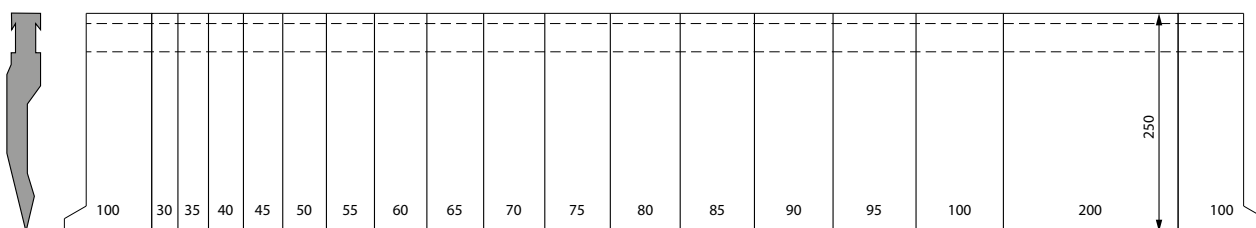

Speciale segmentaties op aanvraag.

Alle bovengereedschappen met andere radius op aanvraag verkrijgbaar.

Maximaal gereedschapsgewicht:

Grijper XTC - max. 15.0 kg

Grijper BC/MTC - max. 25.0 kg



Modular Tool Changer



Bending Cell





P2 RF-AC/85° H250

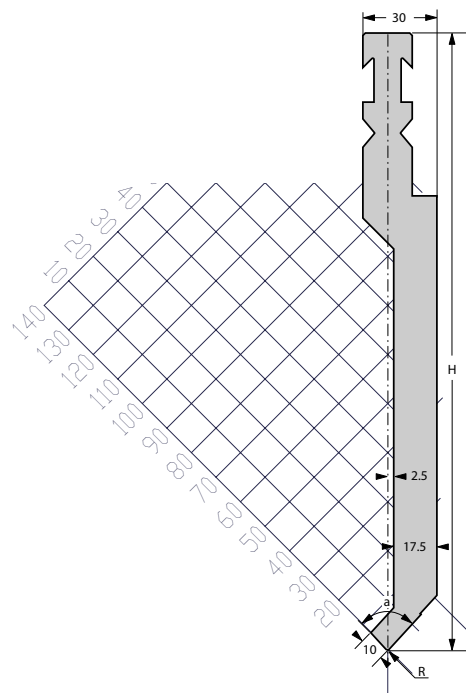

[R] Radius (mm)	1.0
Neushoek	85°
[H] Hoogte (mm)	250

* Andere radius op aanvraag

Standaardlengte	Onderdeelnummer
30 mm	65208.0002.5001
35 mm	65208.0002.5002
40 mm	65208.0002.5003
45 mm	65208.0002.5004
50 mm	65208.0002.5005
55 mm	65208.0002.5006
60 mm	65208.0002.5007
65 mm	65208.0002.5008
70 mm	65208.0002.5015
75 mm	65208.0002.5016
80 mm	65208.0002.5017

Standaardlengte	Onderdeelnummer
85 mm	65208.0002.5018
90 mm	65208.0002.5019
95 mm	65208.0002.5020
100 mm	65208.0002.5011
200 mm	65208.0002.5012
275 mm	65208.0002.5013
300 mm	65208.0002.5014
515 mm	65208.0002.5019
Hoornset links + rechts	65208.0002.7001
Hoorn links	65208.0002.7002
Hoorn rechts	65208.0002.7003

F_{max} = 1000 kN/m

34.4 kg/m



98.0 mm



P4 RF-AC/85° H250

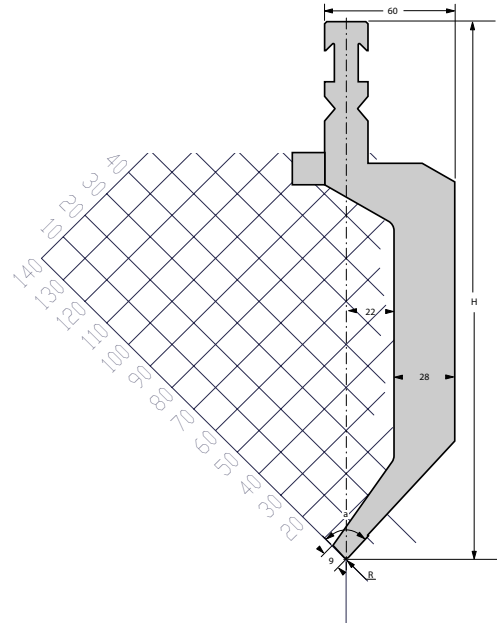

[R] Radius (mm)	1.5
Neushoek	85°
[H] Hoogte (mm)	250

* Andere radius op aanvraag

Standaardlengte	Onderdeelnummer
30 mm	65208.0004.5001
35 mm	65208.0004.5002
40 mm	65208.0004.5003
45 mm	65208.0004.5004
50 mm	65208.0004.5005
55 mm	65208.0004.5006
60 mm	65208.0004.5007
65 mm	65208.0004.5008
70 mm	65208.0004.5015
75 mm	65208.0004.5016
80 mm	65208.0004.5017

Standaardlengte	Onderdeelnummer
85 mm	65208.0004.5018
90 mm	65208.0004.5019
95 mm	65208.0004.5020
100 mm	65208.0004.5011
200 mm	65208.0004.5012
275 mm	65208.0004.5013
300 mm	65208.0004.5014
Hoornset links + rechts	65208.0004.7003
Hoorn links	65208.0004.7001
Hoorn rechts	65208.0004.7002



F max = 600 kN/m



48.3 kg/m



98.0 mm



P5 RF-AC/30° H250

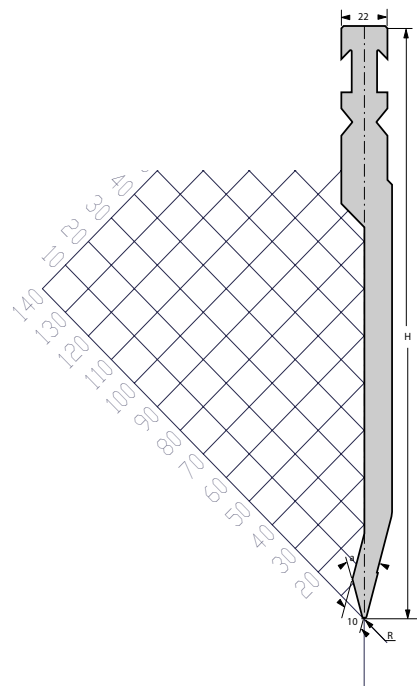

[R] Radius (mm)	1
Neushoek	30°
[H] Hoogte (mm)	250

* Andere radius op aanvraag

Standaardlengte	Onderdeelnummer
30 mm	65208.0005.5001
35 mm	65208.0005.5002
40 mm	65208.0005.5003
45 mm	65208.0005.5004
50 mm	65208.0005.5005
55 mm	65208.0005.5006
60 mm	65208.0005.5007
65 mm	65208.0005.5008
70 mm	65208.0005.5015
75 mm	65208.0005.5016
80 mm	65208.0005.5017

Standaardlengte	Onderdeelnummer
85 mm	65208.0005.5018
90 mm	65208.0005.5019
95 mm	65208.0005.5020
100 mm	65208.0005.5011
200 mm	65208.0005.5012
275 mm	65208.0005.5013
300 mm	65208.0005.5014
515 mm	65208.0005.5021
Hoornset links + rechts	65208.0005.7003
Hoorn links	65208.0005.7001
Hoorn rechts	65208.0005.7002



F max = 750 kN/m



26.0 kg/m



98.0 mm



P7 RF-AC/30° H250

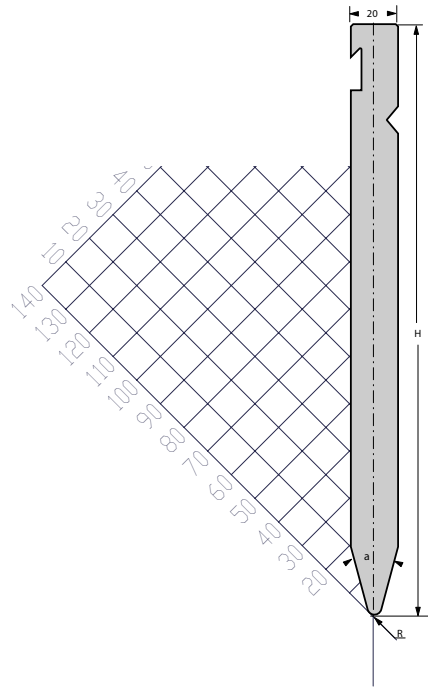
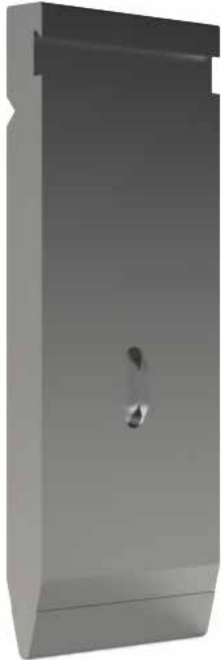

[R] Radius (mm)	3
Neushoek	30°
[H] Hoogte (mm)	250

* Andere radius op aanvraag

Standaardlengte	Onderdeelnummer
30 mm	65208.0007.5001
35 mm	65208.0007.5002
40 mm	65208.0007.5003
45 mm	65208.0007.5004
50 mm	65208.0007.5005
55 mm	65208.0007.5006
60 mm	65208.0007.5007
65 mm	65208.0007.5008
70 mm	65208.0007.5015
75 mm	65208.0007.5016
80 mm	65208.0007.5017

Standaardlengte	Onderdeelnummer
85 mm	65208.0007.5018
90 mm	65208.0007.5019
95 mm	65208.0007.5020
100 mm	65208.0007.5011
200 mm	65208.0007.5012
275 mm	65208.0007.5013
300 mm	65208.0007.5014
515 mm	65208.0007.5026
Hoornset links + rechts	65208.0007.7003
Hoorn links	65208.0007.7001
Hoorn rechts	65208.0007.7002



F max = 1400 kN/m



35.9 kg/m



98.0 mm



Ondergereedschappen

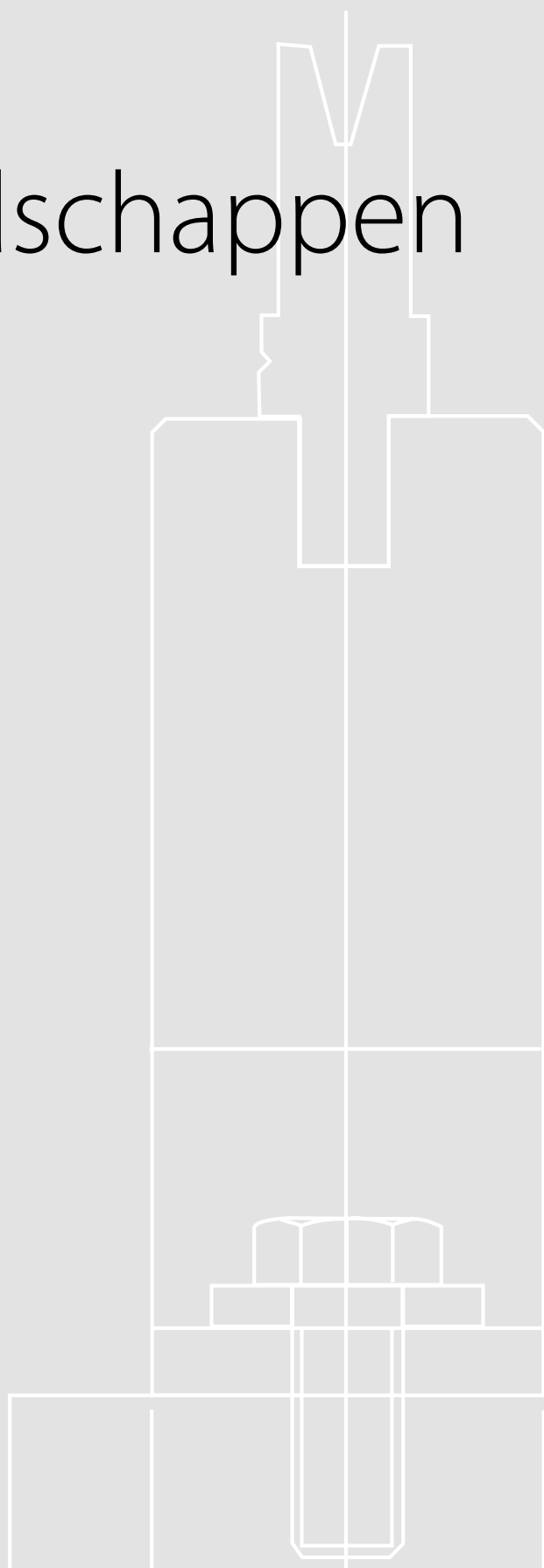





Opties voor lagere tafel

Tafel met hydraulische gereedschapsklemming

T12

(optioneel Xpert 60 - 320 en
Xpert 250 - 1000)

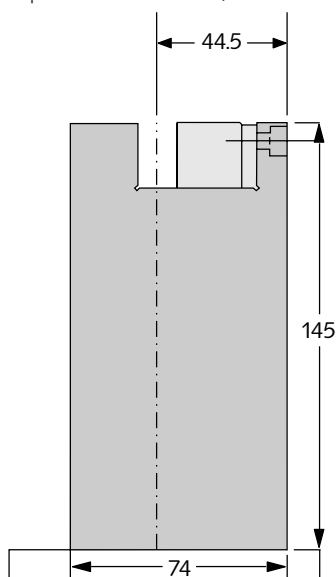

T13

(optioneel Xpert 60 - 320 en
Xpert 250 - 1000)

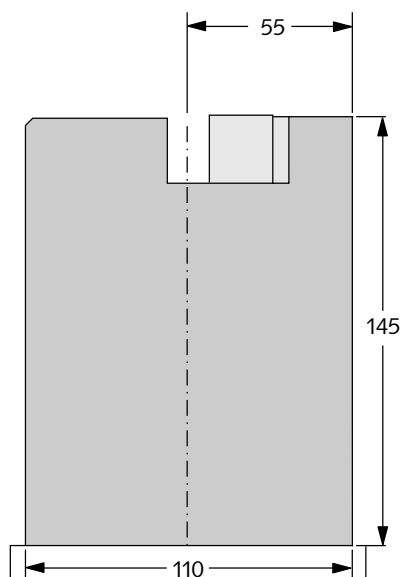



Matrijsdeling

Insteekmatrijs VC L = 1025 sect.

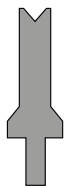

50	55	60	65	70	75	80	85	90	95	100	200

Speciale deling op aanvraag.

Verder zijn alle ondergereedschappen verkrijgbaar met gewijzigde radii, matrijshoek en hoogte (niet standaard).



V6C/30° H55

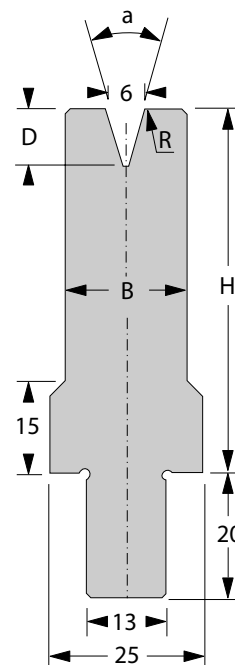
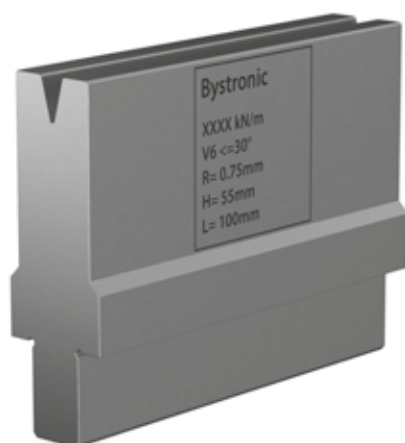

[R] Radius (mm)	0.75
[a] V - Hoek	30°
[H] Hoogte (mm)	55

[B] Breedte (mm)	20
[D] Diepte (mm)	9.3

* Andere radius op aanvraag

Standaardlengte	Onderdeelnummer
50 mm	64208.0006.5001
55 mm	64208.0006.5002
60 mm	64208.0006.5003
65 mm	64208.0006.5004
70 mm	64208.0006.5005
75 mm	64208.0006.5006
80 mm	64208.0006.5007
85 mm	64208.0006.5008
90 mm	64208.0006.5009
95 mm	64208.0006.5010
100 mm	64208.0006.5011

Standaardlengte	Onderdeelnummer
200 mm	64208.0006.5012
275 mm	64208.0006.5013
300 mm	64208.0006.5014
515 mm	64208.0006.5015
1025 mm sect.	64208.0006.5000



F max 30° = 400 kN/m



10.9 kg/m



Insteekmatrijs 13 mm



V6C/30° H100

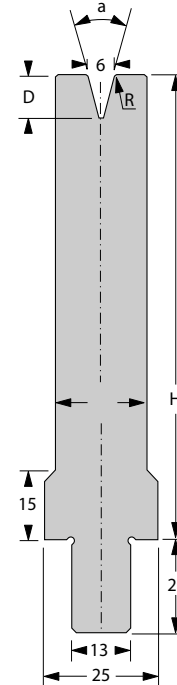

[R] Radius (mm)	0.75
[a] V - Hoek	30°
[H] Hoogte (mm)	100

[B] Breedte (mm)	20
[D] Diepte (mm)	9.3

* Andere radius op aanvraag

Standaardlengte	Onderdeelnummer
50 mm	64208.0006.5016
55 mm	64208.0006.5017
60 mm	64208.0006.5018
65 mm	64208.0006.5019
70 mm	64208.0006.5020
75 mm	64208.0006.5021
80 mm	64208.0006.5022
85 mm	64208.0006.5023
90 mm	64208.0006.5024
95 mm	64208.0006.5025
100 mm	64208.0006.5026

Standaardlengte	Onderdeelnummer
200 mm	64208.0006.5027
275 mm	64208.0006.5028
300 mm	64208.0006.5029
515 mm	64208.0006.5030
1025 mm sect.	64208.0006.5031



F max 30° = 400 kN/m



18.0 kg/m



Insteekmatrijs 13 mm



V8C/30° H55

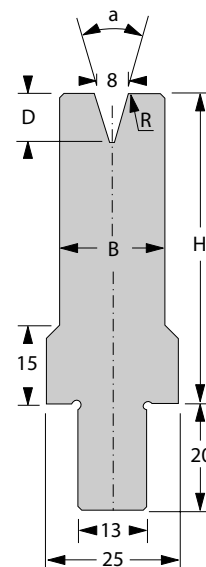

[R] Radius (mm)	1
[a] V - Hoek	30°
[H] Hoogte (mm)	55

[B] Breedte (mm)	20
[D] Diepte (mm)	11.2

* Andere radius op aanvraag

Standaardlengte	Onderdeelnummer
50 mm	64208.0008.5001
55 mm	64208.0008.5002
60 mm	64208.0008.5003
65 mm	64208.0008.5004
70 mm	64208.0008.5005
75 mm	64208.0008.5006
80 mm	64208.0008.5007
85 mm	64208.0008.5008
90 mm	64208.0008.5009
95 mm	64208.0008.5010
100 mm	64208.0008.5011

Standaardlengte	Onderdeelnummer
200 mm	64208.0008.5012
275 mm	64208.0008.5013
300 mm	64208.0008.5014
515 mm	64208.0008.5015
1025 mm sect.	64208.0008.5000



F max 30° = 400 kN/m



10.8 kg/m



Insteekmatrijs 13 mm



V8C/30° H100

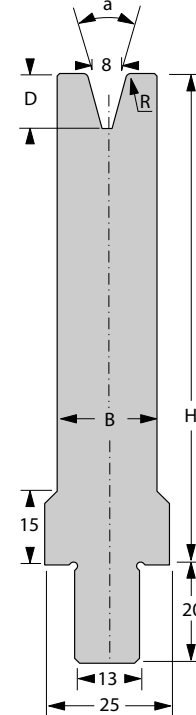

[R] Radius (mm)	1
[a] V - Hoek	30°
[H] Hoogte (mm)	100

[B] Breedte (mm)	20
[D] Diepte (mm)	11.2

* Andere radius op aanvraag

Standaardlengte	Onderdeelnummer
50 mm	64208.0008.5016
55 mm	64208.0008.5017
60 mm	64208.0008.5018
65 mm	64208.0008.5019
70 mm	64208.0008.5020
75 mm	64208.0008.5021
80 mm	64208.0008.5022
85 mm	64208.0008.5023
90 mm	64208.0008.5024
95 mm	64208.0008.5025
100 mm	64208.0008.5026

Standaardlengte	Onderdeelnummer
200 mm	64208.0008.5027
275 mm	64208.0008.5028
300 mm	64208.0008.5029
515 mm	64208.0008.5030
1025 mm sect.	64208.0008.5165



F max 30° = 300 kN/m



17.8 kg/m



Insteekmatrijs 13 mm



V10C/30° H55

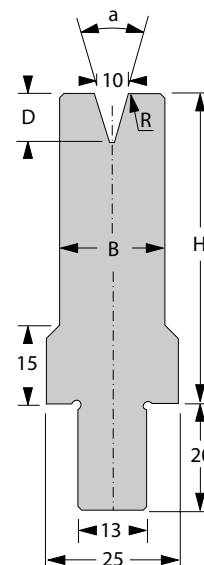
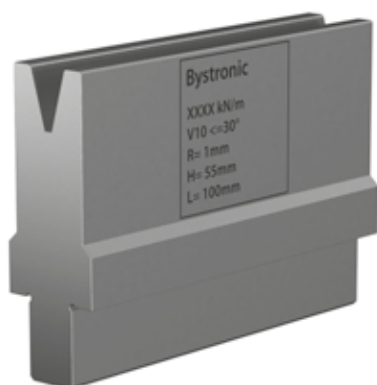

[R] Radius (mm)	1
[a] V - Hoek	30°
[H] Hoogte (mm)	55

[B] Breedte (mm)	20
[D] Diepte (mm)	14.9

* Andere radius op aanvraag

Standaardlengte	Onderdeelnummer
50 mm	64208.0010.5001
55 mm	64208.0010.5002
60 mm	64208.0010.5003
65 mm	64208.0010.5004
70 mm	64208.0010.5005
75 mm	64208.0010.5006
80 mm	64208.0010.5007
85 mm	64208.0010.5008
90 mm	64208.0010.5009
95 mm	64208.0010.5010
100 mm	64208.0010.5011
200 mm	64208.0010.5012

Standaardlengte	Onderdeelnummer
275 mm	64208.0010.5013
300 mm	64208.0010.5014
515 mm	64208.0010.5015
1025 mm sect.	64208.0010.5000



F max 30° = 200 kN/m



10.6 kg/m



Insteekmatrijs 13 mm



V10C/30° H100

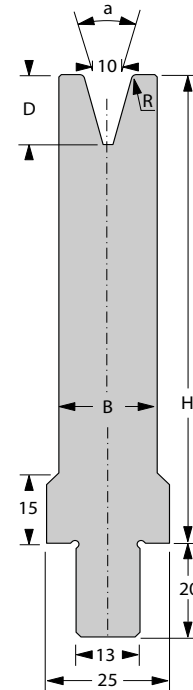

[R] Radius (mm)	1
[a] V - Hoek	30°
[H] Hoogte (mm)	100

[B] Breedte (mm)	20
[D] Diepte (mm)	14.9

* Andere radius op aanvraag

Standaardlengte	Onderdeelnummer
50 mm	64208.0010.5016
55 mm	64208.0010.5017
60 mm	64208.0010.5018
65 mm	64208.0010.5019
70 mm	64208.0010.5020
75 mm	64208.0010.5021
80 mm	64208.0010.5022
85 mm	64208.0010.5023
90 mm	64208.0010.5024
95 mm	64208.0010.5025
100 mm	64208.0010.5026

Standaardlengte	Onderdeelnummer
200 mm	64208.0010.5027
275 mm	64208.0010.5028
300 mm	64208.0010.5029
515 mm	64208.0010.5030
1025 mm sect.	64208.0010.5031



F max 30° = 200 kN/m



17.6 kg/m



Insteekmatrijs 13 mm



V12C/30° H55

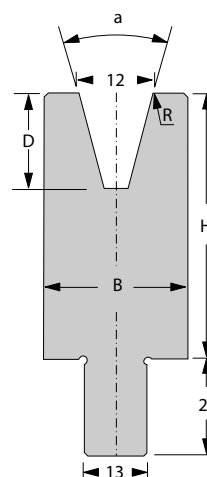

[R] Radius (mm)	1.5
[a] V - Hoek	30°
[H] Hoogte (mm)	55

[B] Breedte (mm)	25
[D] Diepte (mm)	18.6

* Andere radius op aanvraag

Standaardlengte	Onderdeelnummer
50 mm	64208.0012.5001
55 mm	64208.0012.5002
60 mm	64208.0012.5003
65 mm	64208.0012.5004
70 mm	64208.0012.5005
75 mm	64208.0012.5006
80 mm	64208.0012.5007
85 mm	64208.0012.5008
90 mm	64208.0012.5009
95 mm	64208.0012.5010
100 mm	64208.0012.5011

Standaardlengte	Onderdeelnummer
200 mm	64208.0012.5012
275 mm	64208.0012.5013
300 mm	64208.0012.5014
515 mm	64208.0012.5015
1025 mm sect.	64208.0012.5000



F max 30° = 250 kN/m



11.8 kg/m



Insteekmatrijs 13 mm



V12C/30° H100

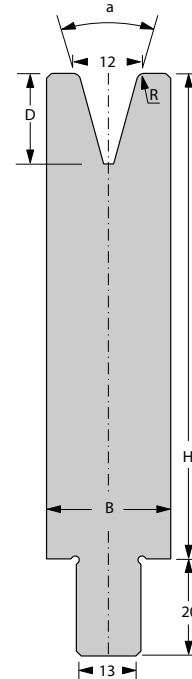

[R] Radius (mm)	1.5
[a] V - Hoek	30°
[H] Hoogte (mm)	100

[B] Breedte (mm)	25
[D] Diepte (mm)	18.6

* Andere radius op aanvraag

Standaardlengte	Onderdeelnummer
50 mm	64208.0012.5017
55 mm	64208.0012.5018
60 mm	64208.0012.5019
65 mm	64208.0012.5020
70 mm	64208.0012.5021
75 mm	64208.0012.5022
80 mm	64208.0012.5023
85 mm	64208.0012.5024
90 mm	64208.0012.5025
95 mm	64208.0012.5026
100 mm	64208.0012.5027

Standaardlengte	Onderdeelnummer
200 mm	64208.0012.5028
275 mm	64208.0012.5029
300 mm	64208.0012.5016
515 mm	64208.0012.5031
1025 mm sect.	64208.0012.5030



F max 30° = 250 kN/m



20.6 kg/m



Insteekmatrijs 13 mm



V16C/30° H55

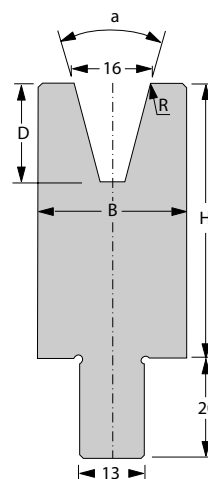

[R] Radius (mm)	2
[a] V - Hoek	30°
[H] Hoogte (mm)	55

[B] Breedte (mm)	30
[D] Diepte (mm)	20.5

* Andere radius op aanvraag

Standaardlengte	Onderdeelnummer
50 mm	64208.0016.5001
55 mm	64208.0016.5002
60 mm	64208.0016.5003
65 mm	64208.0016.5004
70 mm	64208.0016.5005
75 mm	64208.0016.5006
80 mm	64208.0016.5007
85 mm	64208.0016.5008
90 mm	64208.0016.5009
95 mm	64208.0016.5010
100 mm	64208.0016.5011

Standaardlengte	Onderdeelnummer
200 mm	64208.0016.5012
275 mm	64208.0016.5013
300 mm	64208.0016.5014
515 mm	64208.0016.5015
1025 mm sect.	64208.0016.5000



F max 30° = 250 kN/m



13.3 kg/m



Insteekmatrijs 13 mm



V16C/30° H100

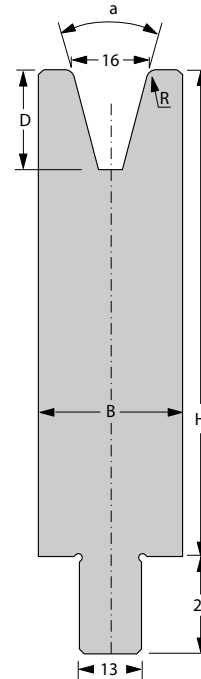

[R] Radius (mm)	2
[a] V - Hoek	30°
[H] Hoogte (mm)	100

[B] Breedte (mm)	30
[D] Diepte (mm)	20.5

* Andere radius op aanvraag

Standaardlengte	Onderdeelnummer
50 mm	64208.0016.5016
55 mm	64208.0016.5017
60 mm	64208.0016.5018
65 mm	64208.0016.5019
70 mm	64208.0016.5020
75 mm	64208.0016.5021
80 mm	64208.0016.5022
85 mm	64208.0016.5023
90 mm	64208.0016.5024
95 mm	64208.0016.5025
100 mm	64208.0016.5026

Standaardlengte	Onderdeelnummer
200 mm	64208.0016.5027
275 mm	64208.0016.5028
300 mm	64208.0016.5029
515 mm	64208.0016.5030
1025 mm sect.	64208.0016.5040



F max 30° = 250 kN/m



23.9 kg/m



Insteekmatrijs 13 mm



V20C/30° H55

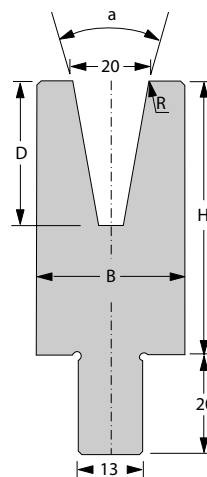

[R] Radius (mm)	2.5
[a] V - Hoek	30°
[H] Hoogte (mm)	55

[B] Breedte (mm)	30
[D] Diepte (mm)	28

* Andere radius op aanvraag

Standaardlengte	Onderdeelnummer
50 mm	64208.0020.5001
55 mm	64208.0020.5002
60 mm	64208.0020.5003
65 mm	64208.0020.5004
70 mm	64208.0020.5005
75 mm	64208.0020.5006
80 mm	64208.0020.5007
85 mm	64208.0020.5008
90 mm	64208.0020.5009
95 mm	64208.0020.5010
100 mm	64208.0020.5011

Standaardlengte	Onderdeelnummer
200 mm	64208.0020.5012
275 mm	64208.0020.5013
300 mm	64208.0020.5014
515 mm	64208.0020.5015
1025 mm sect.	64208.0020.5000



F max 30° = 150 kN/m



12.2 kg/m



Insteekmatrijs 13 mm



V20C/30° H100

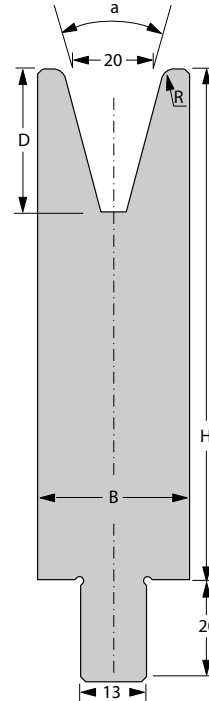

[R] Radius (mm)	2.5
[a] V - Hoek	30°
[H] Hoogte (mm)	100

[B] Breedte (mm)	30
[D] Diepte (mm)	28

* Andere radius op aanvraag

Standaardlengte	Onderdeelnummer
50 mm	64208.0020.5017
55 mm	64208.0020.5018
60 mm	64208.0020.5019
65 mm	64208.0020.5020
70 mm	64208.0020.5021
75 mm	64208.0020.5022
80 mm	64208.0020.5023
85 mm	64208.0020.5024
90 mm	64208.0020.5025
95 mm	64208.0020.5026
100 mm	64208.0020.5027

Standaardlengte	Onderdeelnummer
200 mm	64208.0020.5028
275 mm	64208.0020.5029
300 mm	64208.0020.5016
515 mm	64208.0020.5031
1025 mm sect.	64208.0020.5030



$F_{max} 30^\circ = 150 \text{ kN/m}$



22.8 kg/m



Insteekmatrijs 13 mm



V24C/30° H55

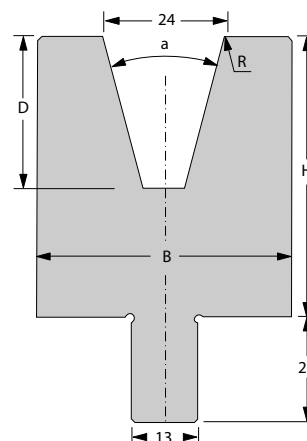

[R] Radius (mm)	3
[a] V - Hoek	30°
[H] Hoogte (mm)	55

[B] Breedte (mm)	40
[D] Diepte (mm)	29.8

* Andere radius op aanvraag

Standaardlengte	Onderdeelnummer
50 mm	64208.0024.5001
55 mm	64208.0024.5002
60 mm	64208.0024.5003
65 mm	64208.0024.5004
70 mm	64208.0024.5005
75 mm	64208.0024.5006
80 mm	64208.0024.5007
85 mm	64208.0024.5008
90 mm	64208.0024.5009
95 mm	64208.0024.5010
100 mm	64208.0024.5011

Standaardlengte	Onderdeelnummer
200 mm	64208.0024.5012
275 mm	64208.0024.5013
300 mm	64208.0024.5014
515 mm	64208.0024.5015
1025 mm sect.	64208.0024.5000



F max 30° = 300 kN/m



15.5 kg/m



Insteekmatrijs 13 mm



V24C/30° H100

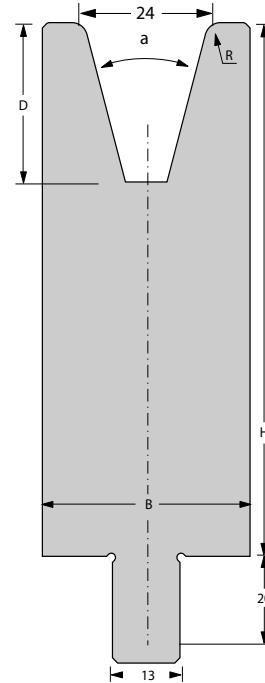

[R] Radius (mm)	3
[a] V - Hoek	30°
[H] Hoogte (mm)	100

[B] Breedte (mm)	40
[D] Diepte (mm)	29.8

* Andere radius op aanvraag

Standaardlengte	Onderdeelnummer
50 mm	64208.0024.5016
55 mm	64208.0024.5017
60 mm	64208.0024.5018
65 mm	64208.0024.5019
70 mm	64208.0024.5020
75 mm	64208.0024.5021
80 mm	64208.0024.5022
85 mm	64208.0024.5023
90 mm	64208.0024.5024
95 mm	64208.0024.5025
100 mm	64208.0024.5026

Standaardlengte	Onderdeelnummer
200 mm	64208.0024.5027
275 mm	64208.0024.5028
300 mm	64208.0024.5029
515 mm	64208.0024.5030
1025 mm sect.	64208.0024.5031



F max 30° = 300 kN/m



29.6 kg/m



Insteekmatrijs 13 mm



V32C/30° H55

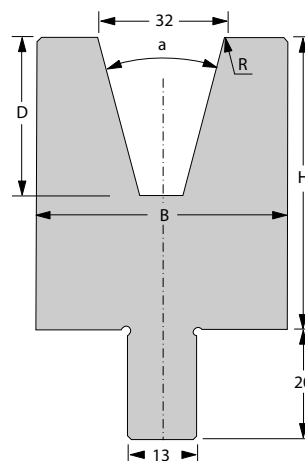
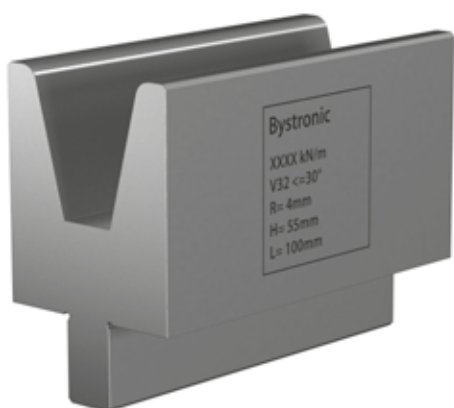

[R] Radius (mm)	4
[a] V - Hoek	30°
[H] Hoogte (mm)	55

[B] Breedte (mm)	48
[D] Diepte (mm)	33.6

* Andere radius op aanvraag

Standaardlengte	Onderdeelnummer
50 mm	64208.0032.5001
55 mm	64208.0032.5002
60 mm	64208.0032.5003
65 mm	64208.0032.5004
70 mm	64208.0032.5005
75 mm	64208.0032.5006
80 mm	64208.0032.5007
85 mm	64208.0032.5008
90 mm	64208.0032.5009
95 mm	64208.0032.5010
100 mm	64208.0032.5011

Standaardlengte	Onderdeelnummer
200 mm	64208.0032.5012
275 mm	64208.0032.5013
300 mm	64208.0032.5014
515 mm	64208.0032.5015
1025 mm sect.	64208.0032.5000



F max 30° = 300 kN/m



16.7 kg/m



Insteekmatrijs 13 mm



V32C/30° H100

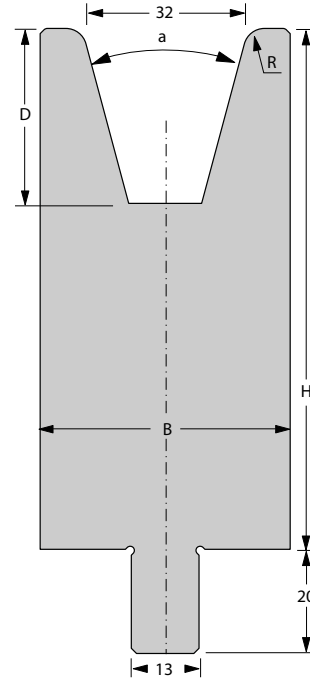

[R] Radius (mm)	4
[a] V - Hoek	30°
[H] Hoogte (mm)	100

[B] Breedte (mm)	48
[D] Diepte (mm)	33.6

* Andere radius op aanvraag

Standaardlengte	Onderdeelnummer
50 mm	64208.0032.5017
55 mm	64208.0032.5018
60 mm	64208.0032.5019
65 mm	64208.0032.5020
70 mm	64208.0032.5021
75 mm	64208.0032.5022
80 mm	64208.0032.5023
85 mm	64208.0032.5024
90 mm	64208.0032.5025
95 mm	64208.0032.5026
100 mm	64208.0032.5027

Standaardlengte	Onderdeelnummer
200 mm	64208.0032.5028
275 mm	64208.0032.5029
300 mm	64208.0032.5016
515 mm	64208.0032.5031
1025 mm sect.	64208.0032.5030



F max 30° = 300 kN/m



33.7 kg/m



Insteekmatrijs 13 mm



V40C/60° H55

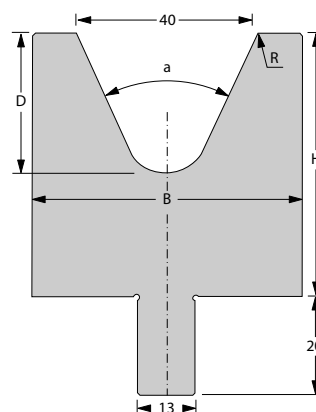
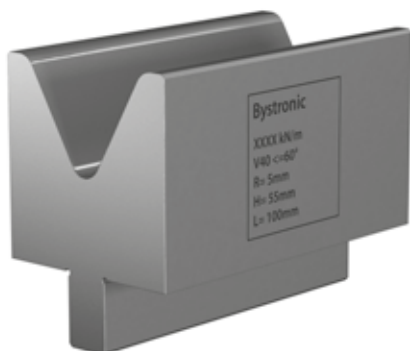

[R] Radius (mm)	5
[a] V - Hoek	60°
[H] Hoogte (mm)	55

[B] Breedte (mm)	55
[D] Diepte (mm)	29.6

* Andere radius op aanvraag

Standaardlengte	Onderdeelnummer
50 mm	64208.0040.5001
55 mm	64208.0040.5002
60 mm	64208.0040.5003
65 mm	64208.0040.5004
70 mm	64208.0040.5005
75 mm	64208.0040.5006
80 mm	64208.0040.5007
85 mm	64208.0040.5008
90 mm	64208.0040.5009
95 mm	64208.0040.5010
100 mm	64208.0040.5011

Standaardlengte	Onderdeelnummer
200 mm	64208.0040.5012
275 mm	64208.0040.5013
300 mm	64208.0040.5014
515 mm	64208.0040.5015
1025 mm sect.	64208.0040.5000



F max 60° = 1800 kN/m



20.5 kg/m



Insteekmatrijs 13 mm



V40C/60° H100

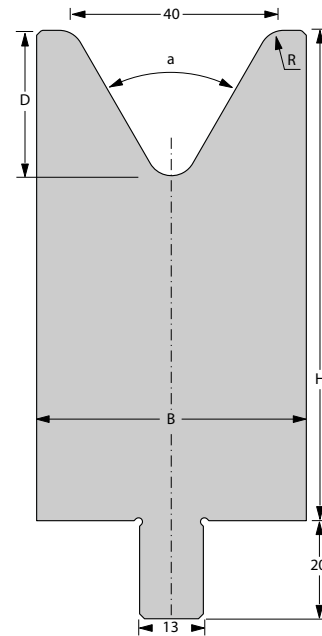

[R] Radius (mm)	5
[a] V - Hoek	60°
[H] Hoogte (mm)	100

[B] Breedte (mm)	55
[D] Diepte (mm)	29.6

* Andere radius op aanvraag

Standaardlengte	Onderdeelnummer
50 mm	64208.0040.5017
55 mm	64208.0040.5018
60 mm	64208.0040.5019
65 mm	64208.0040.5020
70 mm	64208.0040.5021
75 mm	64208.0040.5022
80 mm	64208.0040.5023
85 mm	64208.0040.5024
90 mm	64208.0040.5025
95 mm	64208.0040.5026
100 mm	64208.0040.5027

Standaardlengte	Onderdeelnummer
200 mm	64208.0040.5028
275 mm	64208.0040.5029
300 mm	64208.0040.5016
515 mm	64208.0040.5031
1025 mm sect.	64208.0040.5030



$F_{max} 60^\circ = 1300 \text{ kN/m}$



39.9 kg/m



Insteekmatrijs 13 mm



V50C/60° H55

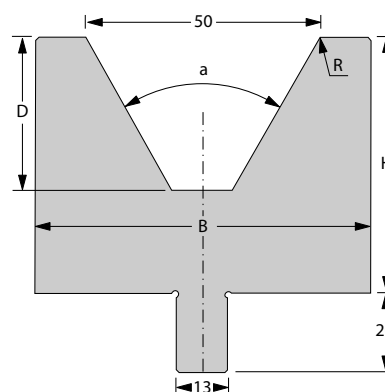
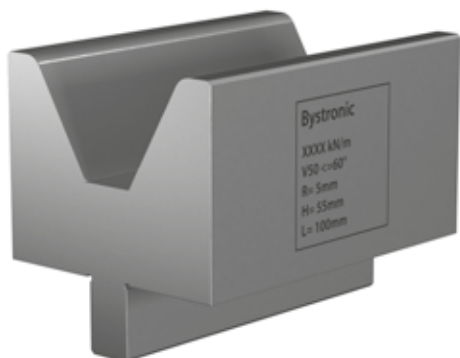

[R] Radius (mm)	5
[a] V - Hoek	60°
[H] Hoogte (mm)	55

[B] Breedte (mm)	70
[D] Diepte (mm)	30.3

* Andere radius op aanvraag

Standaardlengte	Onderdeelnummer
50 mm	64208.0050.5001
55 mm	64208.0050.5002
60 mm	64208.0050.5003
65 mm	64208.0050.5004
70 mm	64208.0050.5005
75 mm	64208.0050.5006
80 mm	64208.0050.5007
85 mm	64208.0050.5008
90 mm	64208.0050.5009
95 mm	64208.0050.5010
100 mm	64208.0050.5011

Standaardlengte	Onderdeelnummer
200 mm	64208.0050.5012
275 mm	64208.0050.5013
300 mm	64208.0050.5014
515 mm	64208.0050.5015
1025 mm sect.	64208.0050.5000



F max 60° = 1200 kN/m



24.5 kg/m



Insteekmatrijs 13 mm



V50C/60° H100

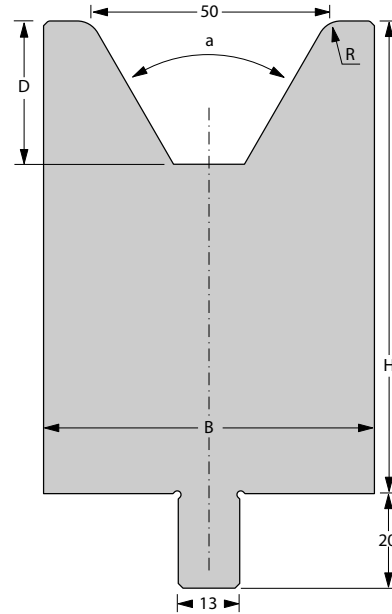

[R] Radius (mm)	5
[a] V - Hoek	60°
[H] Hoogte (mm)	100

[B] Breedte (mm)	70
[D] Diepte (mm)	30.3

* Andere radius op aanvraag

Standaardlengte	Onderdeelnummer
50 mm	64208.0050.5016
55 mm	64208.0050.5017
60 mm	64208.0050.5018
65 mm	64208.0050.5019
70 mm	64208.0050.5020
75 mm	64208.0050.5021
80 mm	64208.0050.5022
85 mm	64208.0050.5023
90 mm	64208.0050.5024
95 mm	64208.0050.5025
100 mm	64208.0050.5026

Standaardlengte	Onderdeelnummer
200 mm	64208.0050.5027
275 mm	64208.0050.5028
300 mm	64208.0050.5029
515 mm	64208.0050.5031
1025 mm sect.	64208.0050.5030



F max 60° = 2000 kN/m



49.2 kg/m



Insteekmatrijs 13 mm



V60C/60° H65

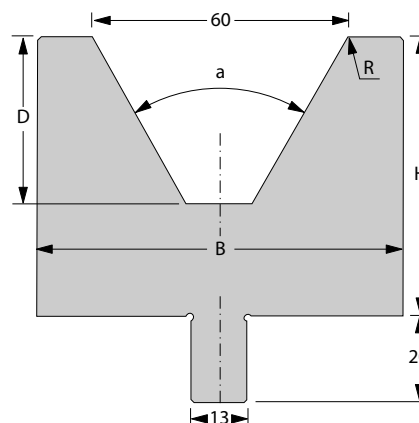
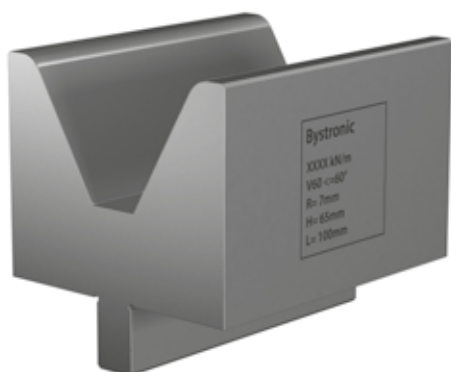

[R] Radius (mm)	7
[a] V - Hoek	60°
[H] Hoogte (mm)	65

[B] Breedte (mm)	80
[D] Diepte (mm)	39

* Andere radius op aanvraag

Standaardlengte	Onderdeelnummer
50 mm	64208.0060.5001
55 mm	64208.0060.5002
60 mm	64208.0060.5003
65 mm	64208.0060.5004
70 mm	64208.0060.5005
75 mm	64208.0060.5006
80 mm	64208.0060.5007
85 mm	64208.0060.5008
90 mm	64208.0060.5009
95 mm	64208.0060.5010
100 mm	64208.0060.5011

Standaardlengte	Onderdeelnummer
200 mm	64208.0060.5012
275 mm	64208.0060.5013
300 mm	64208.0060.5014
515 mm	64208.0060.5031
1025 mm sect.	64208.0060.5000



F max 60° = 1600 kN/m



31.4 kg/m



Insteekmatrijs 13 mm



V60C/60° H100

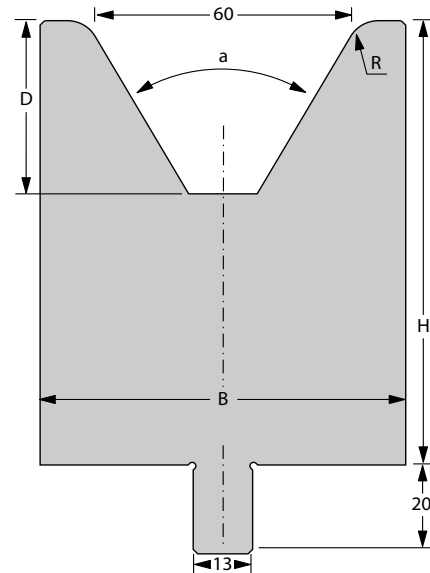

[R] Radius (mm)	7
[a] V - Hoek	60°
[H] Hoogte (mm)	100

[B] Breedte (mm)	80
[D] Diepte (mm)	39

* Andere radius op aanvraag

Standaardlengte	Onderdeelnummer
50 mm	64208.0060.5016
55 mm	64208.0060.5017
60 mm	64208.0060.5018
65 mm	64208.0060.5019
70 mm	64208.0060.5020
75 mm	64208.0060.5021
80 mm	64208.0060.5022
85 mm	64208.0060.5023
90 mm	64208.0060.5024
95 mm	64208.0060.5025
100 mm	64208.0060.5026

Standaardlengte	Onderdeelnummer
200 mm	64208.0060.5015
275 mm	64208.0060.5027
300 mm	64208.0060.5028
1025 mm sect.	64208.0060.5030



F max 60° = 2000 kN/m



53.4 kg/m



Insteekmatrijs 13 mm



V80C/80° H65

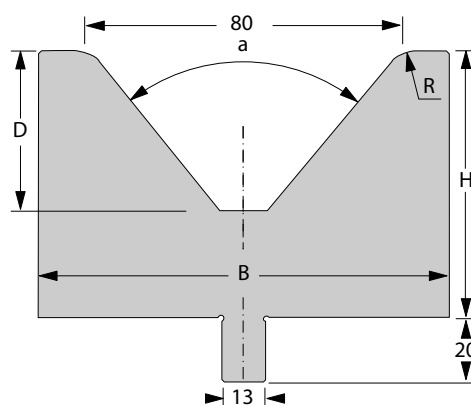
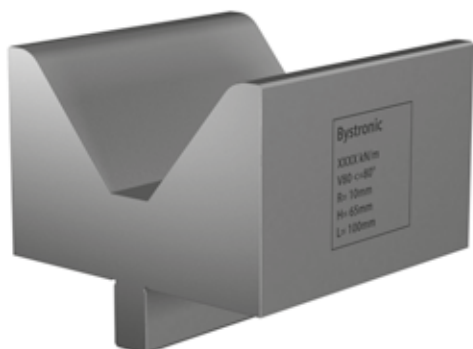

[R] Radius (mm)	10
[a] V - Hoek	80°
[H] Hoogte (mm)	65

[B] Breedte (mm)	100
[D] Diepte (mm)	38.7

* Andere radius op aanvraag

Standaardlengte	Onderdeelnummer
50 mm	64208.0080.5001
55 mm	64208.0080.5002
60 mm	64208.0080.5003
65 mm	64208.0080.5004
70 mm	64208.0080.5005
75 mm	64208.0080.5006
80 mm	64208.0080.5007
85 mm	64208.0080.5008
90 mm	64208.0080.5009
95 mm	64208.0080.5010
100 mm	64208.0080.5011

Standaardlengte	Onderdeelnummer
200 mm	64208.0080.5012
275 mm	64208.0080.5013
300 mm	64208.0080.5014
515 mm	64208.0080.5029
1025 mm sect.	64208.0080.5000



F max 80° = 1400 kN/m



38.6 kg/m



Insteekmatrijs 13 mm



V80C/80° H100

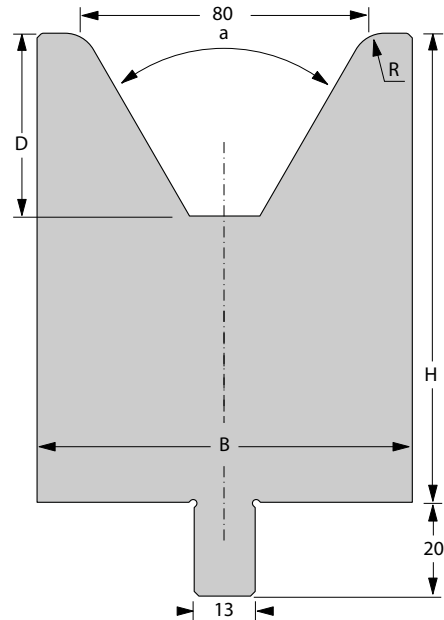

[R] Radius (mm)	10
[a] V - Hoek	80°
[H] Hoogte (mm)	100

[B] Breedte (mm)	100
[D] Diepte (mm)	38.7

* Andere radius op aanvraag

Standaardlengte	Onderdeelnummer
50 mm	64208.0080.5015
55 mm	64208.0080.5016
60 mm	64208.0080.5017
65 mm	64208.0080.5018
70 mm	64208.0080.5019
75 mm	64208.0080.5020
80 mm	64208.0080.5021
85 mm	64208.0080.5022
90 mm	64208.0080.5023
95 mm	64208.0080.5024
100 mm	64208.0080.5025

Standaardlengte	Onderdeelnummer
200 mm	64208.0080.5026
275 mm	64208.0080.5027
300 mm	64208.0080.5028
1025 mm sect.	64208.0080.5030



F max 80° = 1400 kN/m



66.0 kg/m



Insteekmatrijs 13 mm



V100C/80° H85

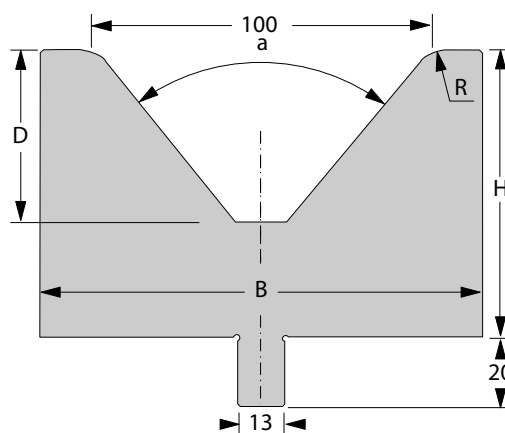
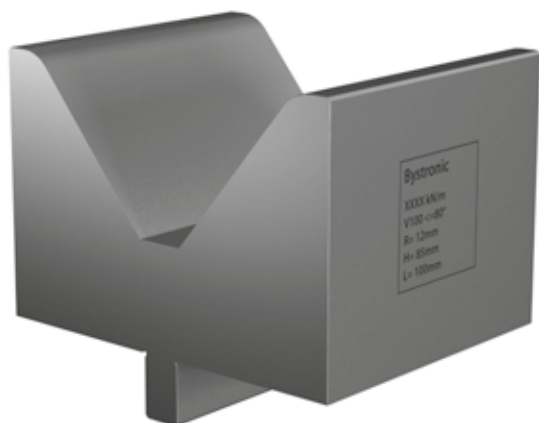

[R] Radius (mm)	12
[a] V - Hoek	80°
[H] Hoogte (mm)	85

[B] Breedte (mm)	125
[D] Diepte (mm)	50.5

* Andere radius op aanvraag

Standaardlengte	Onderdeelnummer
50 mm	64208.0100.5001
55 mm	64208.0100.5002
60 mm	64208.0100.5003
65 mm	64208.0100.5004
70 mm	64208.0100.5005
75 mm	64208.0100.5006
80 mm	64208.0100.5007
85 mm	64208.0100.5008
90 mm	64208.0100.5009
95 mm	64208.0100.5010
100 mm	64208.0100.5011

Standaardlengte	Onderdeelnummer
200 mm	64208.0100.5012
275 mm	64208.0100.5013
300 mm	64208.0100.5014
1025 mm sect.	64208.0100.5000



F max 80° = 1800 kN/m



60.5 kg/m



Insteekmatrijs 13 mm



V120C/80° H105

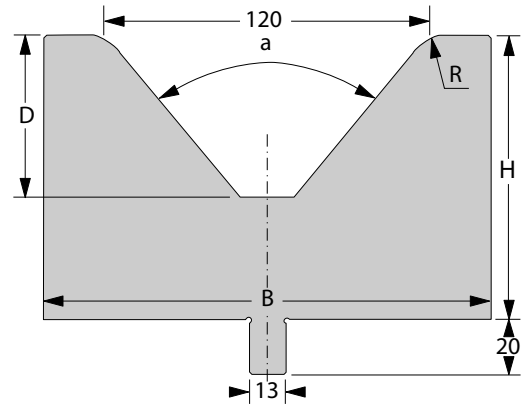
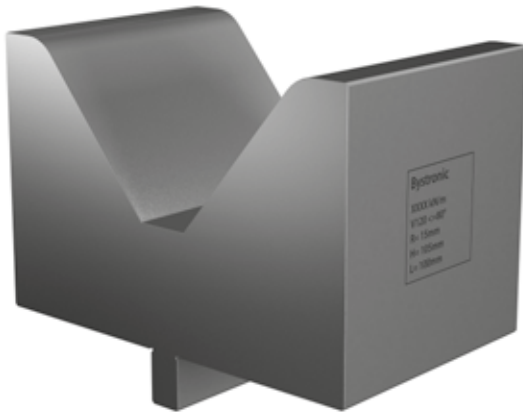

[R] Radius (mm)	15
[a] V - Hoek	80°
[H] Hoogte (mm)	105

[B] Breedte (mm)	160
[D] Diepte (mm)	59.5

* Andere radius op aanvraag

Standaardlengte	Onderdeelnummer
50 mm	64208.0120.5001
55 mm	64208.0120.5002
60 mm	64208.0120.5003
65 mm	64208.0120.5004
70 mm	64208.0120.5005
75 mm	64208.0120.5006
80 mm	64208.0120.5007
85 mm	64208.0120.5008
90 mm	64208.0120.5009
95 mm	64208.0120.5010
100 mm	64208.0120.5011

Standaardlengte	Onderdeelnummer
200 mm	64208.0120.5012
275 mm	64208.0120.5013
300 mm	64208.0120.5014
1025 mm sect.	64208.0120.5000



F max 80° = 2000 kN/m



101.0 kg/m



Insteekmatrijs 13 mm



V6SC/30° H55

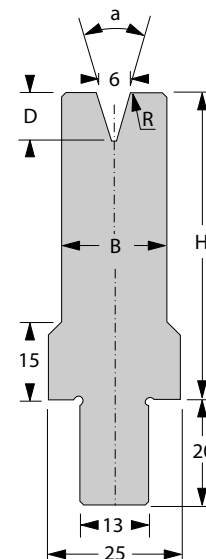

[R] Radius (mm)	0.75
[a] V - Hoek	30°
[H] Hoogte (mm)	55

[B] Breedte (mm)	12
[D] Diepte (mm)	9.3

* Andere radius op aanvraag

Standaardlengte	Onderdeelnummer
50 mm	64208.0006.5101
55 mm	64208.0006.5102
60 mm	64208.0006.5103
65 mm	64208.0006.5104
70 mm	64208.0006.5105
75 mm	64208.0006.5106
80 mm	64208.0006.5107
85 mm	64208.0006.5108
90 mm	64208.0006.5109
95 mm	64208.0006.5110
100 mm	64208.0006.5111

Standaardlengte	Onderdeelnummer
200 mm	64208.0006.5112
275 mm	64208.0006.5113
300 mm	64208.0006.5114
515 mm	64208.0006.5115
1025 mm sect.	64208.0006.5100



F max 30° = 100 kN/m



8.1 kg/m



Insteekmatrijs 13 mm



V6SC/30° H100

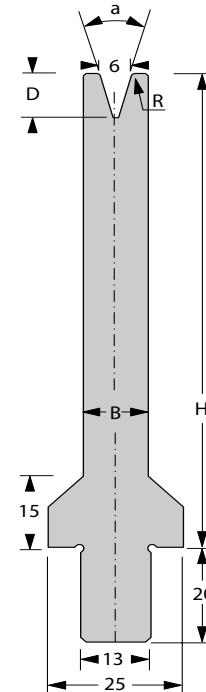

[R] Radius (mm)	0.75
[a] V - Hoek	30°
[H] Hoogte (mm)	100

[B] Breedte (mm)	12
[D] Diepte (mm)	9.3

* Andere radius op aanvraag

Standaardlengte	Onderdeelnummer
50 mm	64208.0006.5151
55 mm	64208.0006.5152
60 mm	64208.0006.5153
65 mm	64208.0006.5154
70 mm	64208.0006.5155
75 mm	64208.0006.5156
80 mm	64208.0006.5157
85 mm	64208.0006.5158
90 mm	64208.0006.5159
95 mm	64208.0006.5160
100 mm	64208.0006.5161

Standaardlengte	Onderdeelnummer
200 mm	64208.0006.5162
275 mm	64208.0006.5163
300 mm	64208.0006.5164
515 mm	64208.0006.5165
1025 mm sect.	64208.0006.5150



F max 30° = 100 kN/m



12.3 kg/m



Insteekmatrijs 13 mm



V8SC/30° H55

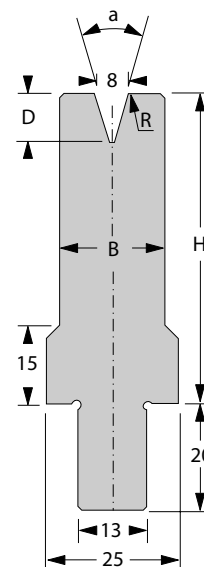

[R] Radius (mm)	1
[a] V - Hoek	30°
[H] Hoogte (mm)	55

[B] Breedte (mm)	14
[D] Diepte (mm)	11.2

* Andere radius op aanvraag

Standaardlengte	Onderdeelnummer
50 mm	64208.0008.5102
55 mm	64208.0008.5103
60 mm	64208.0008.5104
65 mm	64208.0008.5105
70 mm	64208.0008.5106
75 mm	64208.0008.5107
80 mm	64208.0008.5108
85 mm	64208.0008.5109
90 mm	64208.0008.5110
95 mm	64208.0008.5111
100 mm	64208.0008.5112

Standaardlengte	Onderdeelnummer
200 mm	64208.0008.5113
275 mm	64208.0008.5114
300 mm	64208.0008.5115
515 mm	64208.0008.5116
1025 mm sect.	64208.0008.5100



F max 30° = 100 kN/m



8.7 kg/m



Insteekmatrijs 13 mm



V8SC/30° H100

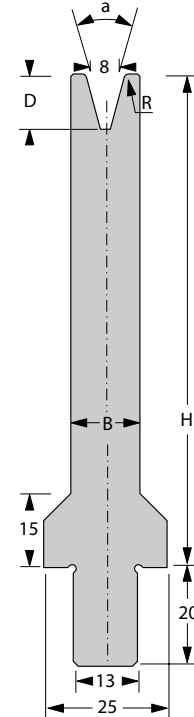

[R] Radius (mm)	1
[a] V - Hoek	30°
[H] Hoogte (mm)	100

[B] Breedte (mm)	14
[D] Diepte (mm)	11.2

* Andere radius op aanvraag

Standaardlengte	Onderdeelnummer
50 mm	64208.0008.5151
55 mm	64208.0008.5152
60 mm	64208.0008.5153
65 mm	64208.0008.5154
70 mm	64208.0008.5155
75 mm	64208.0008.5156
80 mm	64208.0008.5157
85 mm	64208.0008.5158
90 mm	64208.0008.5159
95 mm	64208.0008.5160
100 mm	64208.0008.5161

Standaardlengte	Onderdeelnummer
200 mm	64208.0008.5162
275 mm	64208.0008.5163
300 mm	64208.0008.5164
515 mm	64208.0008.5166
1025 mm sect.	64208.0008.5150



F max 30° = 1000 kN/m



13.7 kg/m



Insteekmatrijs 13 mm



V10SC/30° H55

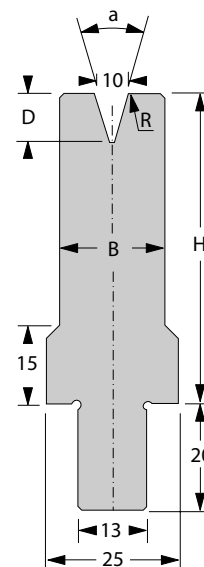

[R] Radius (mm)	1
[a] V - Hoek	30°
[H] Hoogte (mm)	55

[B] Breedte (mm)	16
[D] Diepte (mm)	14.9

* Andere radius op aanvraag

Standaardlengte	Onderdeelnummer
50 mm	64208.0010.5101
55 mm	64208.0010.5102
60 mm	64208.0010.5103
65 mm	64208.0010.5104
70 mm	64208.0010.5105
75 mm	64208.0010.5106
80 mm	64208.0010.5107
85 mm	64208.0010.5108
90 mm	64208.0010.5109
95 mm	64208.0010.5110
100 mm	64208.0010.5111

Standaardlengte	Onderdeelnummer
200 mm	64208.0010.5112
275 mm	64208.0010.5113
300 mm	64208.0010.5114
515 mm	64208.0010.5115
1025 mm sect.	64208.0010.5100



F max 30° = 100 kN/m



9.1 kg/m



Insteekmatrijs 13 mm



V10SC/30° H100

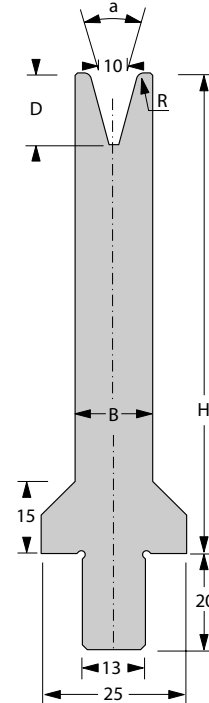

[R] Radius (mm)	1
[a] V - Hoek	30°
[H] Hoogte (mm)	100

[B] Breedte (mm)	16
[D] Diepte (mm)	14.9

* Andere radius op aanvraag

Standaardlengte	Onderdeelnummer
50 mm	64208.0010.5117
55 mm	64208.0010.5118
60 mm	64208.0010.5119
65 mm	64208.0010.5120
70 mm	64208.0010.5121
75 mm	64208.0010.5122
80 mm	64208.0010.5123
85 mm	64208.0010.5124
90 mm	64208.0010.5125
95 mm	64208.0010.5126
100 mm	64208.0010.5127

Standaardlengte	Onderdeelnummer
200 mm	64208.0010.5128
275 mm	64208.0010.5129
300 mm	64208.0010.5130
515 mm	64208.0010.5131
1025 mm sect.	64208.0010.5116



F max 30° = 100 kN/m



14.7 kg/m



Insteekmatrijs 13 mm



V12SC/30° H55

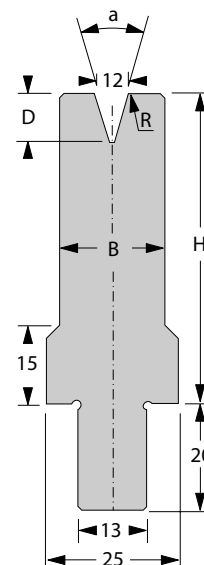
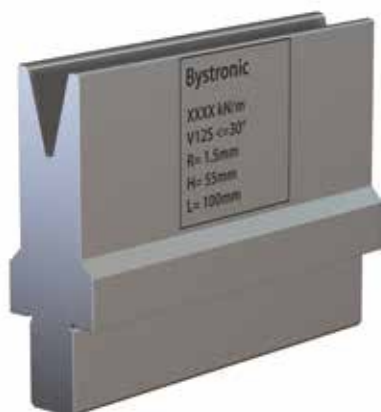

[R] Radius (mm)	1.5
[a] V - Hoek	30°
[H] Hoogte (mm)	55

[B] Breedte (mm)	18
[D] Diepte (mm)	18.6

* Andere radius op aanvraag

Standaardlengte	Onderdeelnummer
50 mm	64208.0012.5101
55 mm	64208.0012.5102
60 mm	64208.0012.5103
65 mm	64208.0012.5104
70 mm	64208.0012.5105
75 mm	64208.0012.5106
80 mm	64208.0012.5107
85 mm	64208.0012.5108
90 mm	64208.0012.5109
95 mm	64208.0012.5110
100 mm	64208.0012.5111

Standaardlengte	Onderdeelnummer
200 mm	64208.0012.5112
275 mm	64208.0012.5113
300 mm	64208.0012.5114
515 mm	64208.0012.5115
1025 mm sect.	64208.0012.5100



F max 30° = 100 kN/m



9.5 kg/m



Insteekmatrijs 13 mm



V12SC/30° H100

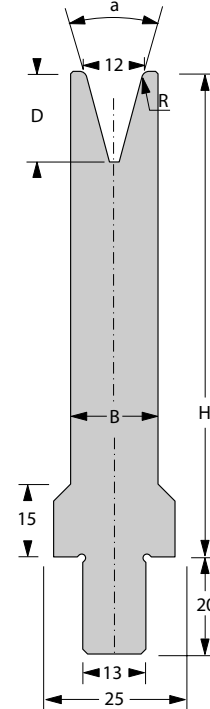

[R] Radius (mm)	1.5
[a] V - Hoek	30°
[H] Hoogte (mm)	100

[B] Breedte (mm)	18
[D] Diepte (mm)	18.6

* Andere radius op aanvraag

Standaardlengte	Onderdeelnummer
50 mm	64208.0012.5117
55 mm	64208.0012.5118
60 mm	64208.0012.5119
65 mm	64208.0012.5120
70 mm	64208.0012.5121
75 mm	64208.0012.5122
80 mm	64208.0012.5123
85 mm	64208.0012.5124
90 mm	64208.0012.5125
95 mm	64208.0012.5126
100 mm	64208.0012.5127

Standaardlengte	Onderdeelnummer
200 mm	64208.0012.5128
275 mm	64208.0012.5129
300 mm	64208.0012.5130
515 mm	64208.0012.5131
1025 mm sect.	64208.0012.5116



F max 30° = 100 kN/m



15.9 kg/m



Insteekmatrijs 13 mm



Toedrukgereedschappen Afvlakgereedschappen

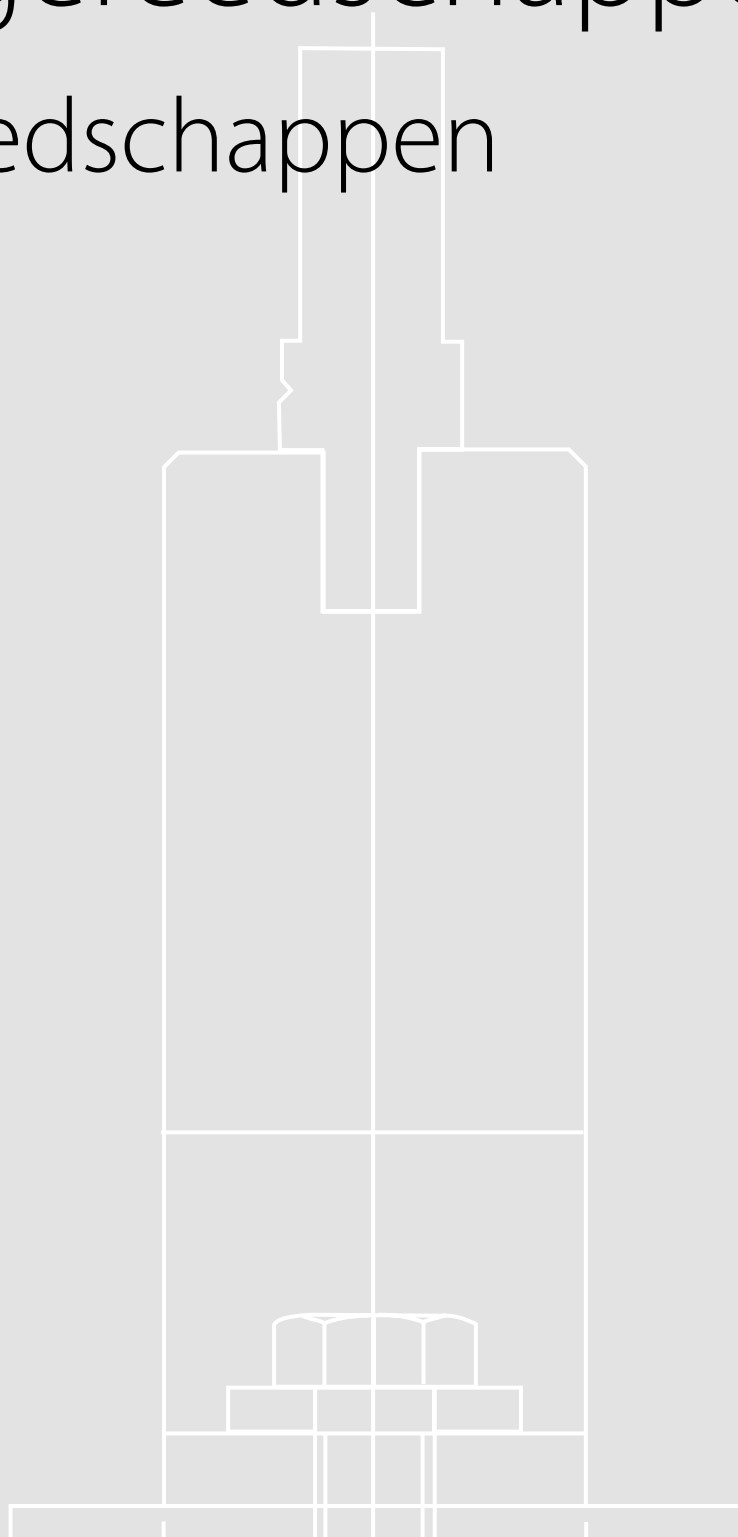





P11 RF-AC H250

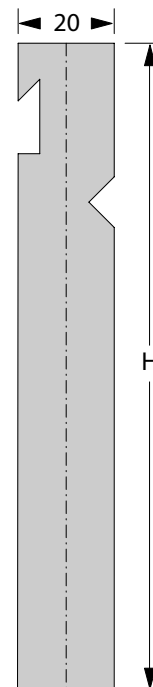

[B] Breedte (mm)	20
[H] Hoogte (mm)	250

Standaardlengte	Onderdeelnummer
30 mm	65208.0011.5001
35 mm	65208.0011.5002
40 mm	65208.0011.5003
45 mm	65208.0011.5004
50 mm	65208.0011.5005
55 mm	65208.0011.5006
60 mm	65208.0011.5007
65 mm	65208.0011.5008
70 mm	65208.0011.5009
75 mm	65208.0011.5010
80 mm	65208.0011.5011

Standaardlengte	Onderdeelnummer
85 mm	65208.0011.5012
90 mm	65208.0011.5013
95 mm	65208.0011.5014
100 mm	65208.0011.5015
200 mm	65208.0011.5016
275 mm	65208.0011.5017
300 mm	65208.0011.5018
515 mm	65208.0011.5023
1175 mm sect.	65208.0011.5000

F_{max} = 1400 kN/m

35.9 kg/m



98.0 mm



P900/8 RF-AC/30° H250

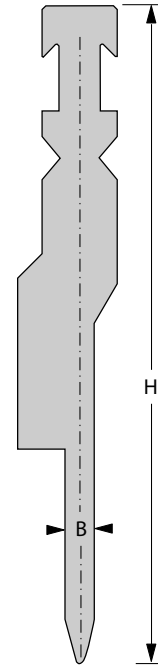

[B] Breedte (mm)	26.5
[H] Hoogte (mm)	250

Standaardlengte	Onderdeelnummer
30 mm	65208.0900.5002
35 mm	65208.0900.5003
40 mm	65208.0900.5004
45 mm	65208.0900.5005
50 mm	65208.0900.5006
55 mm	65208.0900.5007
60 mm	65208.0900.5008
65 mm	65208.0900.5009
70 mm	65208.0900.5010
75 mm	65208.0900.5011
80 mm	65208.0900.5012

Standaardlengte	Onderdeelnummer
85 mm	65208.0900.5013
90 mm	65208.0900.5014
95 mm	65208.0900.5015
100 mm	65208.0900.5016
200 mm	65208.0900.5017
275 mm	65208.0900.5018
300 mm	65208.0900.5019
515 mm	65208.0900.5020
1175 mm sect.	65208.0900.5000



F_{max} = 1000 kN/m



29.2 kg/m



P900/10 RF-AC/30° H250

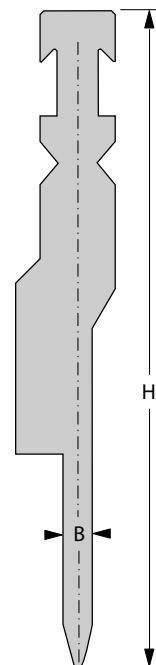

[B] Breedte (mm) 26.5

[H] Hoogte (mm) 250

Standaardlengte	Onderdeelnummer
30 mm	65208.0900.5050
35 mm	65208.0900.5041
40 mm	65208.0900.5042
45 mm	65208.0900.5043
50 mm	65208.0900.5044
55 mm	65208.0900.5045
60 mm	65208.0900.5046
65 mm	65208.0900.5047
70 mm	65208.0900.5048
75 mm	65208.0900.5049
80 mm	65208.0900.5040

Standaardlengte	Onderdeelnummer
85 mm	65208.0900.5051
90 mm	65208.0900.5052
95 mm	65208.0900.5053
100 mm	65208.0900.5054
200 mm	65208.0900.5055
275 mm	65208.0900.5056
300 mm	65208.0900.5057
515 mm	65208.0900.5058
1175 mm sect.	65208.0900.5059



F max = 1000 kN/m



29.2 kg/m



P900/12 RF-AC/30° H250

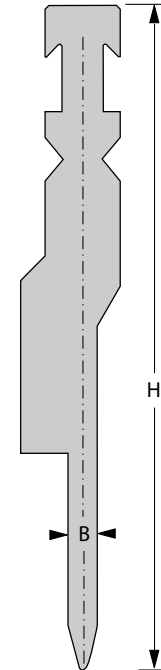

[B] Breedte (mm)	26.5
[H] Hoogte (mm)	250

Standaardlengte	Onderdeelnummer
30 mm	65208.0900.5021
35 mm	65208.0900.5022
40 mm	65208.0900.5023
45 mm	65208.0900.5024
50 mm	65208.0900.5025
55 mm	65208.0900.5026
60 mm	65208.0900.5027
65 mm	65208.0900.5028
70 mm	65208.0900.5029
75 mm	65208.0900.5030
80 mm	65208.0900.5031

Standaardlengte	Onderdeelnummer
85 mm	65208.0900.5032
90 mm	65208.0900.5033
95 mm	65208.0900.5034
100 mm	65208.0900.5035
200 mm	65208.0900.5036
275 mm	65208.0900.5037
300 mm	65208.0900.5001
515 mm	65208.0900.5038
1175 mm sect.	65208.0900.5039



F max = 1000 kN/m



34.3 kg/m



V-Flat B40

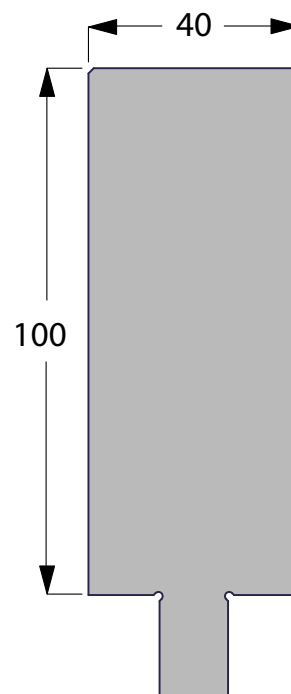

[B] Breedte (mm)	40
[H] Hoogte (mm)	100

Standaardlengte	Onderdeelnummer
50 mm	64208.0000.5001
55 mm	64208.0000.5002
60 mm	64208.0000.5003
65 mm	64208.0000.5004
70 mm	64208.0000.5005
75 mm	64208.0000.5006
80 mm	64208.0000.5007
85 mm	64208.0000.5008
90 mm	64208.0000.5009
95 mm	64208.0000.5010
100 mm	64208.0000.5011

Standaardlengte	Onderdeelnummer
200 mm	64208.0000.5012
275 mm	64208.0000.5013
300 mm	64208.0000.5014
515 mm	64208.0000.5015
1025 mm sect.	64208.0000.5000



$F_{\max} 30^\circ = 2000 \text{ kN/m}$



35.5 kg/m



Insteekmatrijs 13 mm



V900/08C

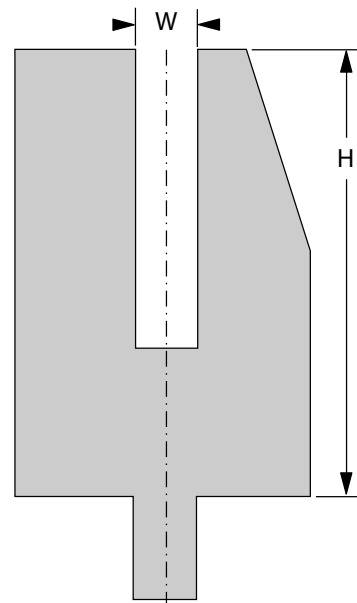

[B] Breedte (mm)	55
[H] Hoogte (mm)	85

Standaardlengte	Onderdeelnummer
50 mm	64208.0900.5003
55 mm	64208.0900.5004
60 mm	64208.0900.5005
65 mm	64208.0900.5006
70 mm	64208.0900.5007
75 mm	64208.0900.5008
80 mm	64208.0900.5009
85 mm	64208.0900.5010
90 mm	64208.0900.5011
95 mm	64208.0900.5012
100 mm	64208.0900.5013

Standaardlengte	Onderdeelnummer
200 mm	64208.0900.5014
275 mm	64208.0900.5015
300 mm	64208.0900.5002
515 mm	64208.0900.5016
1025 mm sect.	64208.0900.5000



$F_{max} 30^\circ = 250 \text{ kN/m}$



35.5 kg/m



Insteekmatrijs 13 mm



V900/10C

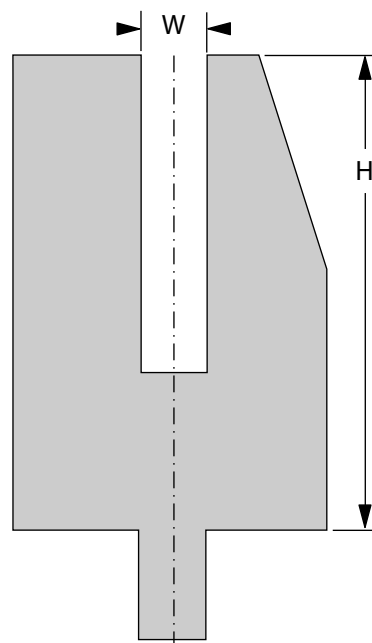

[B] Breedte (mm)	55
[H] Hoogte (mm)	85

Standaardlengte	Onderdeelnummer
50 mm	64208.0900.5032
55 mm	64208.0900.5033
60 mm	64208.0900.5034
65 mm	64208.0900.5047
70 mm	64208.0900.5035
75 mm	64208.0900.5036
80 mm	64208.0900.5037
85 mm	64208.0900.5038
90 mm	64208.0900.5039
95 mm	64208.0900.5040
100 mm	64208.0900.5041

Standaardlengte	Onderdeelnummer
200 mm	64208.0900.5042
275 mm	64208.0900.5043
300 mm	64208.0900.5044
515 mm	64208.0900.5045
1025 mm sect.	64208.0900.5046



F max 30° = 250 kN/m



32.0 kg/m



Insteekmatrijs 13 mm



V900/12C

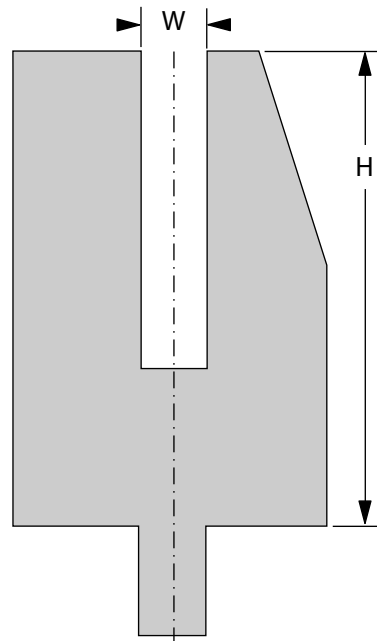

[B] Breedte (mm)	55
[H] Hoogte (mm)	85

Standaardlengte	Onderdeelnummer
50 mm	64208.0900.5017
55 mm	64208.0900.5018
60 mm	64208.0900.5019
65 mm	64208.0900.5020
70 mm	64208.0900.5021
75 mm	64208.0900.5022
80 mm	64208.0900.5023
85 mm	64208.0900.5024
90 mm	64208.0900.5025
95 mm	64208.0900.5026
100 mm	64208.0900.5027

Standaardlengte	Onderdeelnummer
200 mm	64208.0900.5028
275 mm	64208.0900.5029
300 mm	64208.0900.5001
515 mm	64208.0900.5030
1025 mm sect.	64208.0900.5031



$F_{max} 30^\circ = 250 \text{ kN/m}$



31.0 kg/m



Insteekmatrijs 13 mm



Contactadressen wereldwijd

Bystronic Laser AG
Industriestrasse 21
3362 Niederönz
Zwitserland
Tel. +41 62 956 33 33
E-mail info.laser@bystronic.com

Bystronic Australia Pty. Ltd.
4 Latchford Street
Cranbourne West VIC 3977
Australië
Tel.: +61 1300 975 761
E-mail info.au@bystronic.com

Bystronic Austria GmbH
Schärdinger Straße 15
4061 Pasching
Oostenrijk
Tel. +43 7229 64411
E-mail office.at@bystronic.com

Bystronic do Brasil Ltda.
Rua Parma 203
83413-587 – Colombo – PR
Brazilië
Tel. +55 41 3666 9000
E-mail bystronic.br@bystronic.com

Bystronic Canada Ltd
3330 Ridgeway Drive, Unit #11
Mississauga, ON L5L 5Z9
Canada
Tel: +1 905 890 2999
E-mail sales.canada@bystronic.com

Bystronic (Tianjin) Laser Ltd.
No. 46 Xishi Road
Airport Industrial Park
300308 Tianjin
China
Tel: +86 22 5980 1888
E-mail info.tj.cn@bystronic.com

Bystronic Czech Republic s.r.o.
Turanka 115/1222
627 00 Brno Slatina
Tsjechische Republiek
Tel. +420 532 123 314
E-mail info.cz@bystronic.com

Bystronic Ibérica, S.A.
Avda. Tenerife n° 2
Edificio 1, Planta 3, Oficina D
28700 San Sebastián de los Reyes
(Madrid) Spanje
Tel. +34 91 654 48 78
E-mail sales.es@bystronic.com

Bystronic France SAS
Parc Technopolis
3, Avenue du Canada
91940 Les Ulis Cedex
Frankrijk
Tel. +33 1 69 41 99 84
E-mail info.fr@bystronic.com

Bystronic Maschinenbau GmbH
Mühlhäuser Strasse 3
99867 Gotha
Duitsland
Tel. +49 3621 38 30
E-mail info.bending@bystronic.com

Bystronic Deutschland GmbH
Römerstrasse 14
71296 Heimsheim
Duitsland
Tel. +49 7033 46 99 0
E-mail info.de@bystronic.com

Bystronic Magyarország Kft.
Budaörs Business Center
Puskás Tivadarút 5
2040 Budaörs
Hongarije
Tel: +36 23 610 433
E-mail info.hu@bystronic.com

Bystronic Laser India (Pvt) Ltd.
7C, Tadiwala Road
Next to Hotel Pancharatna
Pune 411 001
India
Tel: +91 20 67294800
E-mail info.in@bystronic.com

Bystronic Italia SRL
Via del Lavoro, 30
20813 Bovisio-Masciago
Italië
Tel. +39 0362 5993 1
E-mail sales.it@bystronic.com

Bystronic Japan, Ltd.
2-95-3 Inadaira Musashimurayama-shi
Tokyo 208-0023
Japan
Tel: +81 42 506 8271
E-mail Cesar.Mujica@bystronic.com





Bystronic Laser Pte. Ltd.

(vertegenwoordigingskantoor)
Level 8, MCT Tower, Sky Park,
One City, Jalan USJ 25/1
Subang Jaya
47650 Selangor
Maleisië
Tel: +60 3 8022 8268

Bystronic Mexico S.A. de C.V.

Helios 401 A, Parque Industrial FINSA
Apodaca
66600 Nuevo León
Mexico
Tel. +52 81 2133 7600
E-mail sales.mexico@bystronic.com

Bystronic Benelux B.V.

Duurzaamheidsring 11
4231 EX Meerkerk
Nederland
Tel. +31 184 611 020
E-mail sales.benelux@bystronic.com

Bystronic Japan, Ltd.

3F Bystronic Bldg,
32-18, LS-ro
91 Beon-gil, Dongan-gu Anyang-si
14119 Gyeonggi-do
Korea
Tel. +82 31 389 9800
E-mail info.kr@bystronic.com

Bystronic Polska Sp. z o.o.

Ul. Sokolowska 47
PL-05-806 Sokolów
Polen
Tel. +48 22 331 37 70
E-mail info.pl@bystronic.com

S.C. Bystronic Laser S.R.L.

Str. Poienelor no. 5
Industrial Pro Roman Park
500419 Brasov
Roemenië
Tel: +40 268 322 140
E-mail info.ro@bystronic.com

Bystronic Laser

Zorge Street, 9A
Stroenie 2 (gebouw 2)
125252 Moskou
Rusland
Tel: +7 495 984 71 44
E-mail info.ru@bystronic.com

Bystronic Co., Ltd. (Shanghai)

Room 602, Part A,
No. 388 North Fu Quan Road
Changning District
Shanghai, 200335
Tel. +86 21 6082 9300
E-mail info.sha.cn@bystronic.com

Bystronic Pte. Ltd.

Thye Hong Centre
2 Leng Kee Road #02-04
159086 Singapore
Tel. +65 6472 6300
E-mail info.sg@bystronic.com

Bystronic Scandinavia AB

Metallvägen 30A
195 72 Rosersberg
Zweden
Tel: +46 (0)8 594 415 50
E-mail Services.SE@bystronic.com

Bystronic Sales AG

Industriestrasse 21
3362 Niederönz
Zwitserland
Tel. +41 62 956 37 83
E-mail info.sales@bystronic.com

Bystronic International Laser Ltd.

No. 66, Wuquan Rd.,
Wugu Dist.,
New Taipei City 248
Taiwan (R.O.C)
Tel: +886 2 2299 2699
E-mail hotline.tw@bystronic.com

Bystronic Lazer ve Su Isinlari

Makineleri Sanayi ve Ticaret Ltd. Sti.
Serifali Mevkii, Barbaros Caddesi
No: 66 K:1
34775 Ümraniye/Istanbul
Turkije
Tel: +90 216 464 6160
E-mail info.tr@bystronic.com

LLC Bystronic Ukraine

59 Zhylyanskaya Street
Diplomat Hall, 2nd floor, Office 207
1033 Kyiv
Ukraine
Tel. +380 44 569 74 37
E-mail info.cis@bystronic.com

Bystronic UK Ltd.

6 Wayside Business Park
Wilson's Lane
Coventry
Warwickshire CV6 6NY
Verenigd Koninkrijk
Tel: +44 (0)844 848 5850
E-mail sales.uk@bystronic.com

Bystronic Inc.

2200 West Central Road
US-Hoffman Estates
IL 60192
VS
Tel. +1 847 214 0300
E-mail sales.us@bystronic.com

Bystronic Vietnam Co. Ltd.

38/7 Truong Chinh Str.
Tan Thoi Nhat Ward
District 12
Hochiminh City
Vietnam
Tel: +84 28 3719 2278
E-mail Anh Tuan.Ha@bystronic.com

