

The Bystronic logo is located in the top right corner. It consists of the word "Bystronic" in a white, sans-serif font, positioned over a red square background. The top right corner of the red square is cut off by a diagonal line, creating a triangular shape. The background of the entire page is white.

Bystronic











Best choice.

Bystronic Tools

Our Tools R

Laser | Bending | Waterjet
bystronic.com

Overview about the icons used in this catalogue

	Material / Hardness
	max. permitted load
	method of tool loading
	nature of load
	max. box depth
	weight
	availability / delivery time
	clamping type
	drawing number (BOSbase reference)
	reversible tool
	bottom tool support

Content

Basics.....	4
Bending methods.....	4
Calculations for air bending.....	10
Recommendation starter kits	16
Upper tools R	18
Description upper tool	18
Segmentation of punches.....	22
Upper tools R.....	23
Bottom tools R	58
Lower table options.....	60
Segmentation of bottom tools.....	64
Bottom tools	66
Hemming tools	82
Special applications.....	86
Workshop (ByAcademy)	88
Bystronic world wide	90

Bystronic bending methods

Air bending

For material thicknesses
up to 50 mm mild steel

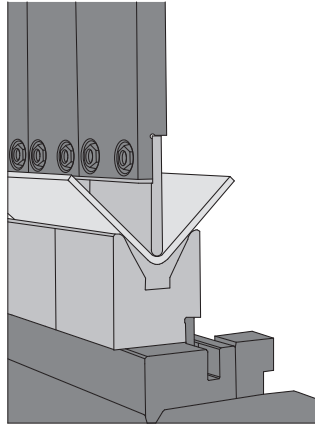

Coining

For material thicknesses
up to 3 mm mild steel

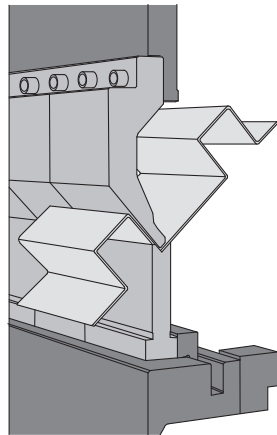

Bystronic bending methods

3-point-bending

Up to 12 mm mild steel

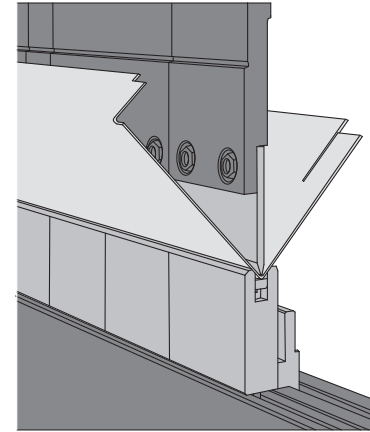

Bystronic bending methods

Principle of air bending

With the air bending method the bending angle is determined by the depth of penetration of the upper tool into the lower die. To that effect and amongst other factors the bending accuracy is mainly dependant upon the positional accuracy of the upper beam. Under load the material is stressed from A to C. After removal of the load the portions AD and EC spring back into thier original positions. In the case of ari bending without bottoming the vees of the bottom tool and the angle of the top tool must be smaller than 90° .

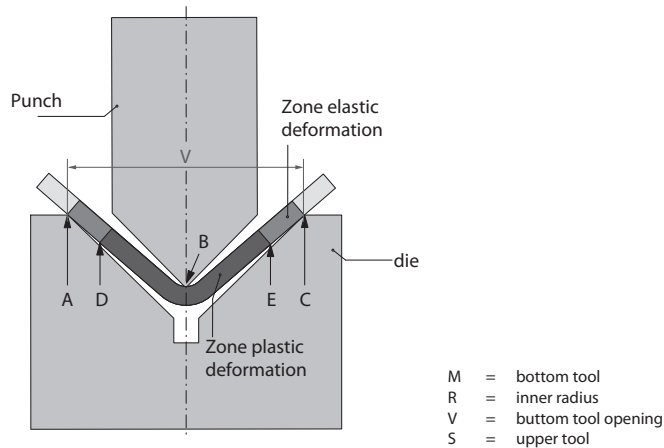

Bystronic bending methods

Principle of bottoming

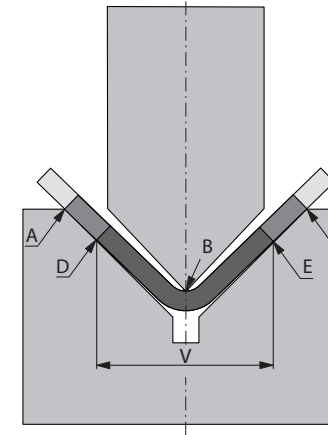

As soon as the areas AD and CE touch the sides of the vee in air bending with bottoming they will spring back into thier original position until the positions of contact have to move to D and E.

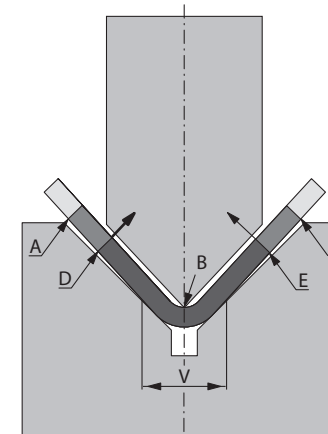

A still further penetration of the top tool will result in a disengagement of the points D and E from the lower die as the points of contact start to move in the overbending is larger than the spring back of the portion located underneath the points of contact the angle of the section after removal of the load will be smaller than the angle of the vee..

Bystronic bending methods

Principle of coining

A further penetration of the top tool will result in a reopening of the section D and E until the top tool completely bottoms out on to the material. (start of the coining process).

The variation of the forces versus the travel of the top tool is a function of the material. The bottoming or coining process corresponds to a continuous reduction of the die opening (V). The smaller the width of the vee during coining results in a corresponding reduction of spring back in comparison to airbending. The bending forces required are 4 to 8 times greater than those required for air bending.

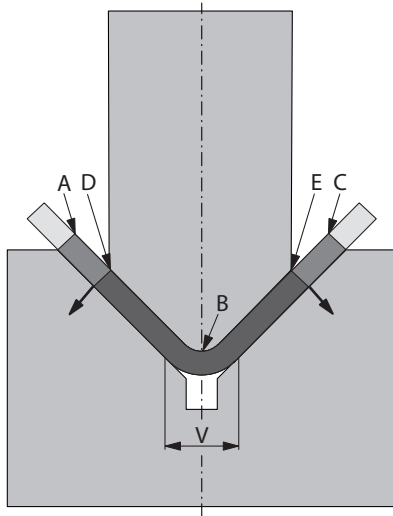

Bystronic bending methods

Principle of 3-point-bending

For the 3-point-bending the bottom tool groove depth (H) is accomplished with an accuracy of 1/1000 mm by means of a precise wedge system. With given sheet metal quality, sheet metal characteristics and plate thickness and taking resilience of the part into account, the bend angle to be produced is governed predictably and accurately by bottom tool depth (F). The top tool segments positioned along the bending line thereby adapts to the bending line of the bottom tools. The hydraulic cushion compensates for machine and material related factors.

The 3-point-bending process is something in between air bending and coining and delivers highest accuracy and flexibility. It opens new possibilities in designing and manufacturing of parts.

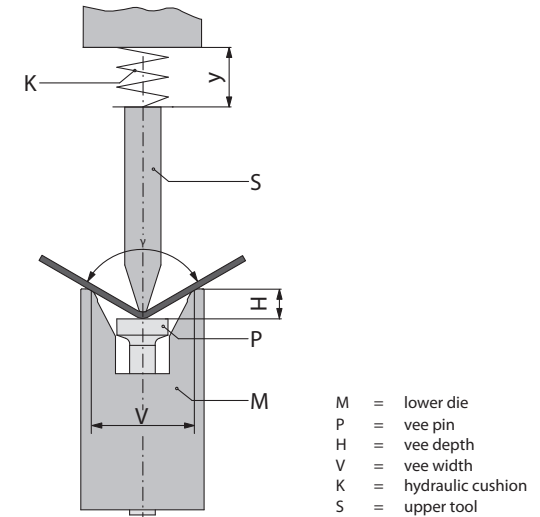

Calculation basics for air bending

Capacity chart for air bending

The given data has been calculated based upon bending material with a tensile strength of $R_m = 420 \text{ N/mm}^2$ over a length of 1 m.

V	6	8	10	12	16	18	20	24	32	40	50	60	80	
R	1	1.2	1.6	2	2.5	2.8	3	3.5	5	6	8	9.5	12	
t	Bending force force in kN/1 m bending length													
	a Minimum flange length in mm													
0.5	25													
	4.3													
0.8	70	48												
	4.6	5.7												
1	115	80	60											
	5	6	7											
1.2		120	90	70										
		6	7.5	8.5										
1.5			150	120										
			8	9										
2.0			235	160	135	120	95							
			10	12	13	14.5	17							
2.5				265	225	200	155	110						
				12.5	14	15.5	17.5	23						
3.0						300	240	165	125					
						15.5	17.5	23.5	28					
4.0								315	235	180				
								25	29	35				
5.0								535	430	310	250			
								26	31	35.5	43			
6.0									610	450	360			
									32	36	44			
8.0										880	690	470		
										40	46	57		
10												800		
												60		
12													1200	
													62	
16														
18														
20														

Sheets with mill scale will increase the bending force by a factor of 1,05–1,1

Calculation basics for air bending

Capacity chart for air bending

V	100	120	130	140	150	160	180	190	200	230	260	290	320	
R	15.5	19	21	23	24.5	26	28	30	32	36	40	45	50	
t	Bending force force in kN/1 m bending length													
	a Minimum flange length in mm													
0.5	25													
	4.3													
0.8	70	48												
	4.6	5.7												
1	115	80	60											
	5	6	7											
1.2		120	90	70										
		6	7.5	8.5										
1.5			150	120										
			8	9										
2.0			235	160	135	120	95							
			10	12	13	14.5	17							
2.5				265	225	200	155	110						
				12.5	14	15.5	17.5	23						
3.0						300	240	165	125					
						15.5	17.5	23.5	28					
4.0								315	235	180				
								25	29	35				
5.0								535	430	310	250			
								26	31	35.5	43			
6.0									610	450	360			
									32	36	44			
8.0										880	690	470		
										40	46	57		
10												800		
												60		
12													1200	
													62	
16														
18														
20														

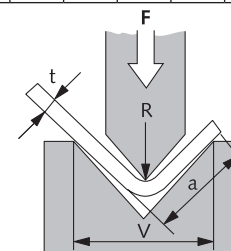

The internal radius R corresponds to approximately 16% of the die opening V.

Calculation basics for air bending

Calculation formulas

Recommended bottom tool opening V for air bending

Material thickness	t	0.5–2.5 mm	3–8 mm	9–10 mm	> 12 mm
Bottom tool opening	V	6 × t	8 × t	10 × t	12 × t

Bending force for

Aluminium	Rm = 300 N/mm ²	F = F (table) × 0.65
Mild steel	Rm = 420 N/mm ²	F = F (table)
Stainless steel	Rm = 700 N/mm ²	F = F (table) × 1.6

Determination of the bending force for air bending (reference data)

$$F = \frac{R_m \times t^2}{V} \times \left(1 + \frac{4 \times t}{V}\right)$$

Conversion: Rm = tensile strength in N/mm²

10 N ≅ 1 kg

10 kN ≅ 1 t

Conversion for minimal internal radii R

thickness t	1	2	3	4	5	6	8	10	12	16	18	20
min. R	1	2	3	5	6	8	12	16	20	28	36	40

Calculation basics for air bending

Tensile strength

Material		Tensile strength	
American	European	KPSI	N/mm ²
6061 Aluminum	Alu 50	42	290
5052 Aluminum	Alu 35	44	303
1010 Mild steel	DC01	53	366
A 536-80 G 60-40-18	GGG-40	58	400
A 351 G CF 8	G-X 6CrNi 18 9	65	450
A 572 G50	S 355 MC	80	550
Domex 80	S 420 MC	80	550
A 36	S 235 JR	80	552
304 Stainless	Inox V2A	85	586
316 Stainless	Inox V4A	87	600
A 572 G 65	S 460 MC	95	655
Domex 100	S 500 MC	102	700
Domex 550	S 550 MC	110	760
Domex 600	S 600 MC	119	820
Weldox 700	Weldox 700	123	850
Domex 650	S 650 MC	128	880
Domex 700	S 700 MC	138	950
4140 Low alloy	42 CrMo 4	145	1000
Weldox 900	Weldox 900	149	1030
Weldox 960	Weldox 960	154	1060
Hardox 400	Hardox 400	181	1250
Hardox 500	Hardox 500	225	1550

Please ask your responsible Consultant for bending high strength materials.

Calculation basis for air bending

Working space determination

Tonnage	Day-light	Day-light	Stroke	Punch height	Working height	Clamping height	Box depth	Die height	Table height	Free space	Width upper beam
	DL mm	DLW mm	SH mm	PH mm	WH mm	CH mm	BH mm	DH mm	TH mm	FS mm	UB mm
		Modufix				**				*	
		Wila				**					
60t	500	420	215	155	116	39	53.2	55	145	184	80
				175	115	60	52.5	55	145	185	80
				250	190	60	105	55	145	110	80
100t	500	420	215	155	116	39	56.7	55	145	184	70
				175	115	60	56	55	145	185	70
				250	190	60	108.5	55	145	110	70
150t	500	420	215	155	116	39	56.7	55	145	184	70
				175	115	60	56	55	145	185	70
				250	190	60	108.5	55	145	110	70
200t	500	420	215	155	116	39	53.2	55	145	184	80
				175	115	60	52.5	55	145	185	80
				250	190	60	105	55	145	110	80
250t	550	470	265	155	116	39	53.2	55	145	234	80
				175	115	60	52.5	55	145	235	80
				250	190	60	105	55	145	160	80
320t	550	470	265	155	116	39	46.2	55	145	234	100
				175	115	60	54.5	55	145	235	100
				250	190	60	98	55	145	160	100

* Not valid for WILA Modufix,

** Clamping height S/R/Wila = 39, RF/RF-A = 60

Calculation formula

for box depth. $BH = (PH - CH - UB : 2) \times 0,7$

To calculate the remaining working day light for given machine and tool combination. $FS = DL - TH - DH - WH$

Calculation basics for air bending

Working space determination

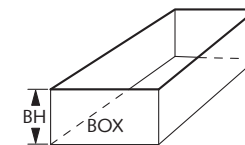
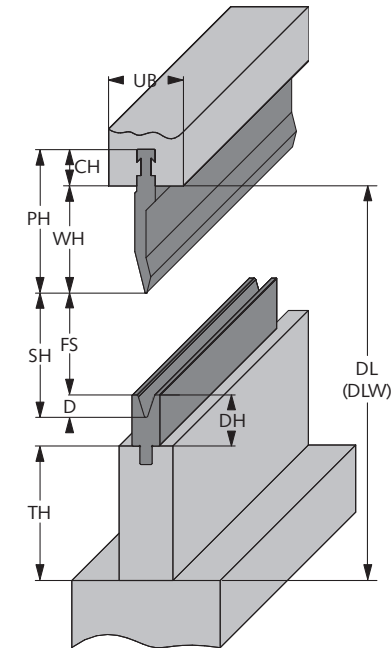

Description upper tools

Clamping R

R mechanical

R hydraulic

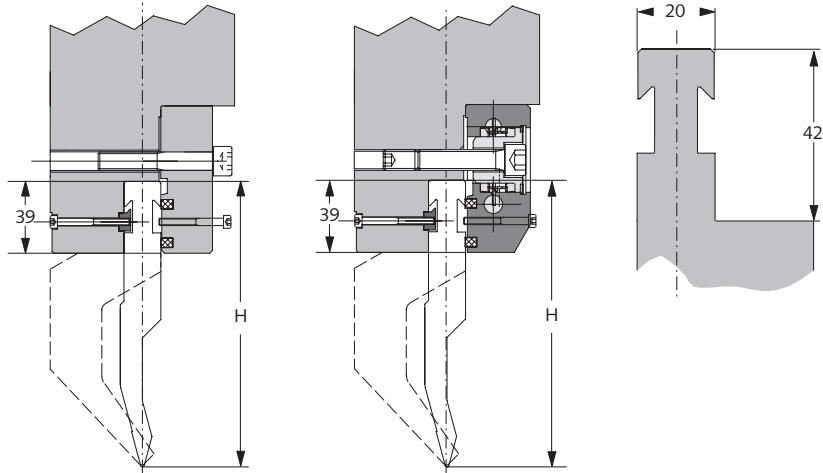

 Head support ≤ 1600 kN/m shoulder supp. > 1600 kN/m

 Sideways and vertical insertion possible

 Head and shoulder supported possible

 Mechanical and hydraulic

 Tools are reversible

Because of the height of the clamping area, R type is suitable for light - medium duty clamping applications.

Description upper tools

Clamping RF

RF mechanical

RF hydraulic

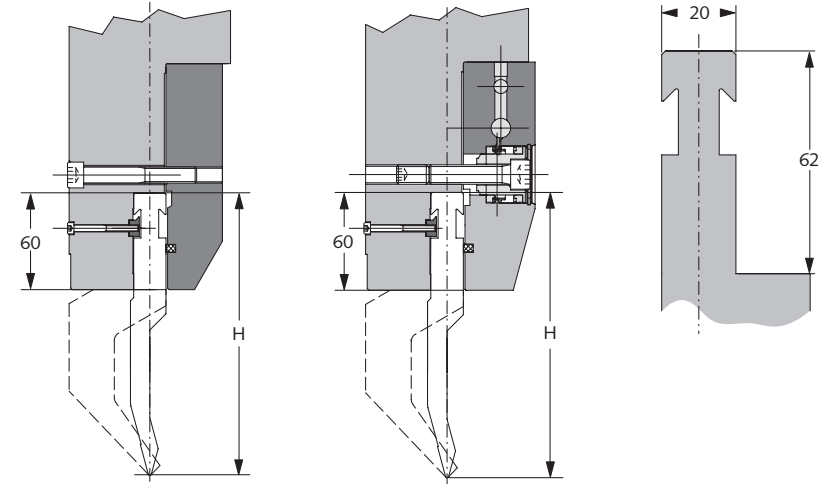

 Head support ≤ 1600 kN/m shoulder supp. > 1600 kN/m

 Sideways and vertical insertion possible

 Head and shoulder supported possible

 Mechanical and hydraulic

 Tools are reversible

Because of the height the RF type clamping is suitable for medium to high applications.

Description upper tools

Clamping RF-A

RF-A hydraulic

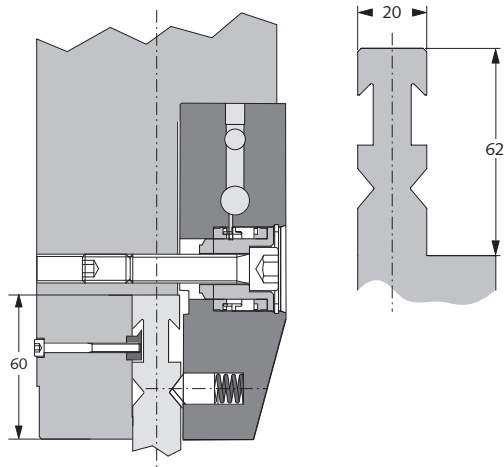

The automatic centering of the RF-A hydraulic clamping system helps to shorten the setup time by up to 20%. This combined with the large clamping area makes it a very popular option among users of both Xpert 60-320 machines and also the large Xpert machines 250 - 1000

Head support ≤ 1600 kN/m shoulder supp. > 1600 kN/m

Sideways and vertical insertion possible

Head and shoulder supported possible

Hydraulic

Tools are reversible

Maximum tool weight
50 kg / m

Description upper tools

Clamping MAMMUT Ergo

MAMMUT Ergo hydraulic

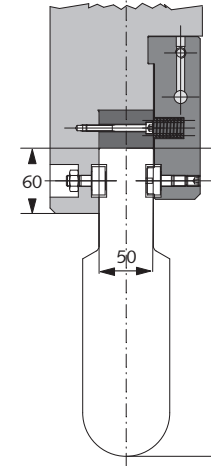

Head supported ≤ 3200 kN/m shoulder su. > 3200 kN/m

Sideways insertion

Head and shoulder supported possible

Hydraulic

Tools are reversible

The MAMMUT Ergo is specially designed for high loads and the use of heavy tools. The MAMMUT Ergo is designed with casters for easy and quick tooling setup.

Segmentation of punches

Horns R / RF / RF-A

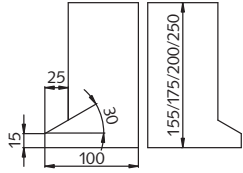

FSC / 1000 mm

(10 + 15 + 20 + 30 + 50 + 100 + 200 + 275 + 300)



Upper tools R

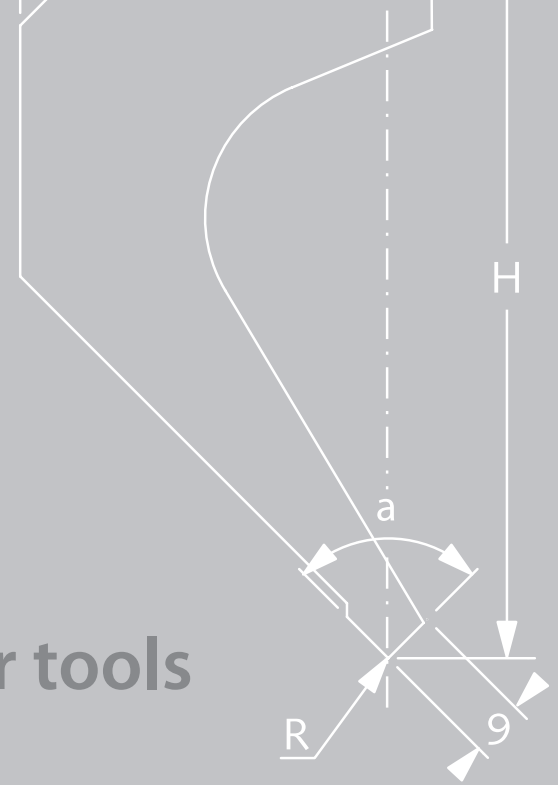

P2 R H155





[R] Radius (mm) 1

Nose angle 85°

[H] Height (mm) 155

 42 CrMo 4

 58 - 62 HRC

 $F_{max} = 1300 \text{ kN/m}$

 Operator side

 Head supported

 21.5 kg/m

 Hydraulic clamping

 57.0 mm

 Ex stock / 24 h

 BOS No. BY1C002

Standard length	Part number
515 mm	65203.0002.5002
1030 mm	65203.0002.3003
1000 mm sect. FSC	65203.0002.0006
Horn set LH + RH	65203.0002.7005

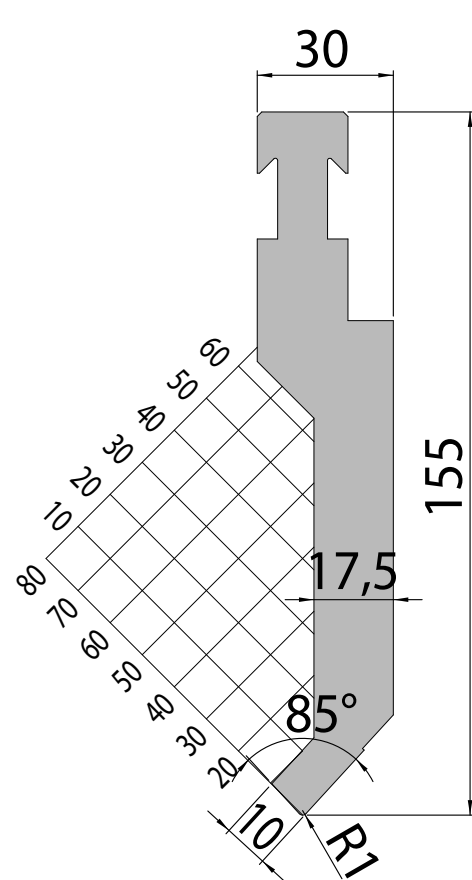

P2 R / 85°
 $F = 1300 \text{ kN/m}$
 $R = 1 \text{ mm}$
 $H = 155 \text{ mm}$

P2 R H250



[R] Radius (mm) 1

Nose angle 85°

[H] Height (mm) 250

 42 CrMo 4

 58 - 62 HRC

 $F_{max} = 1000 \text{ kN/m}$

 Operator side

 Head supported

 34.5 kg/m

 Hydraulic clamping

 124.0 mm

 Ex stock / 24 h

 BOS No. BY10197

Standard length	Part number
515 mm	65203.0002.5007
1030 mm	65203.0002.3004
1000 mm sect. FSC	65203.0002.0005
Horn set LH + RH	65203.0002.7004

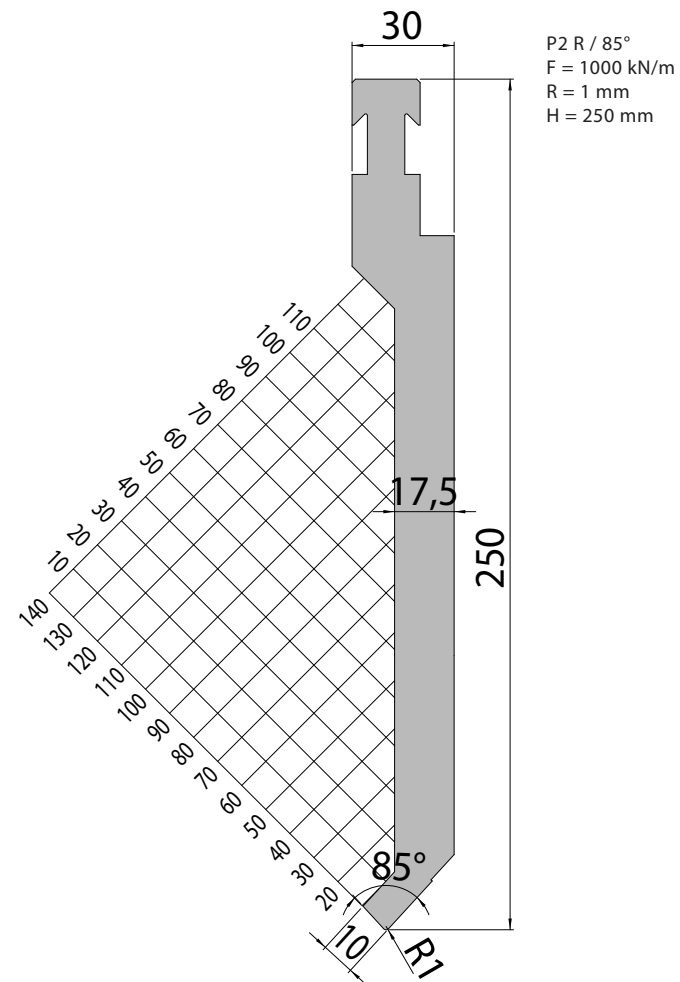

P3 R H155

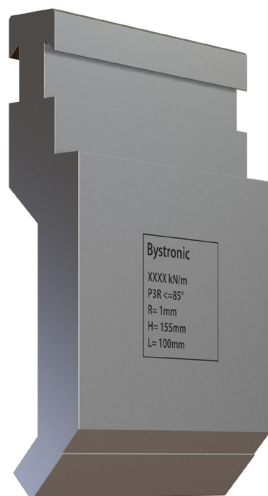

[R] Radius (mm) 1

Nose angle 85°

[H] Height (mm) 155

 42 CrMo 4

 58 - 62 HRC

 $F_{max} = 1300 \text{ kN/m}$

 Operator side

 Head supported

 21.8 kg/m

 Hydraulic clamping

 57.0 mm

 Ex stock / 24 h

 BOS No. IB00551

Standard length	Part number
515 mm	65203.0003.5007
1030 mm	65203.0003.3002
1000 mm sect. FSC	65203.0003.0002
Horn set LH + RH	65203.0003.7001

P3 R / 85°
 $F = 1300 \text{ kN/m}$
 $R = 1 \text{ mm}$
 $H = 155 \text{ mm}$

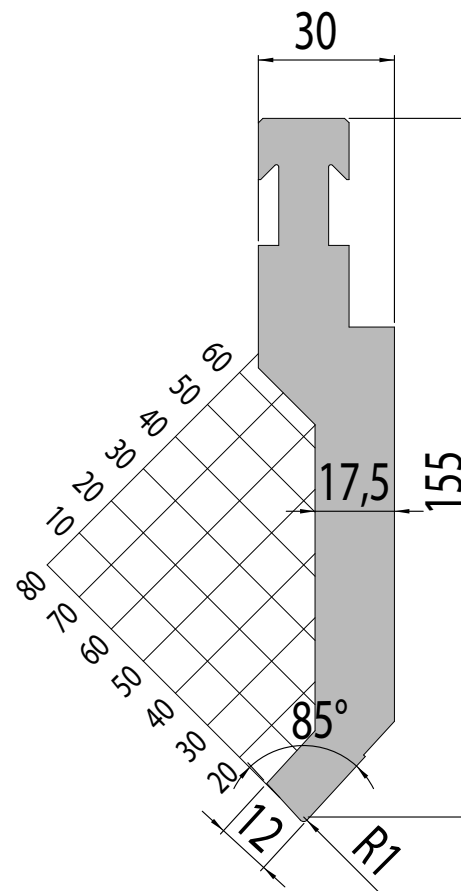

P4 R H155

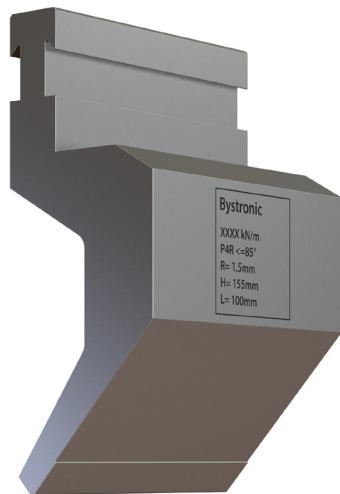

[R] Radius (mm) 1.5

Nose angle 85°

[H] Height (mm) 155

 42 CrMo 4

 58 - 62 HRC

 $F_{max} = 600 \text{ kN/m}$

 Operator side

 Head supported

 29.2 kg/m

 Hydraulic clamping

 57.0 mm

 Ex stock / 24 h

 BOS No. BY1C010

Standard length	Part number
515 mm	65203.0004.5004
1030 mm	65203.0004.3005
1000 mm sect. FSC	65203.0004.0005
Horn set LH + RH	65203.0004.7004

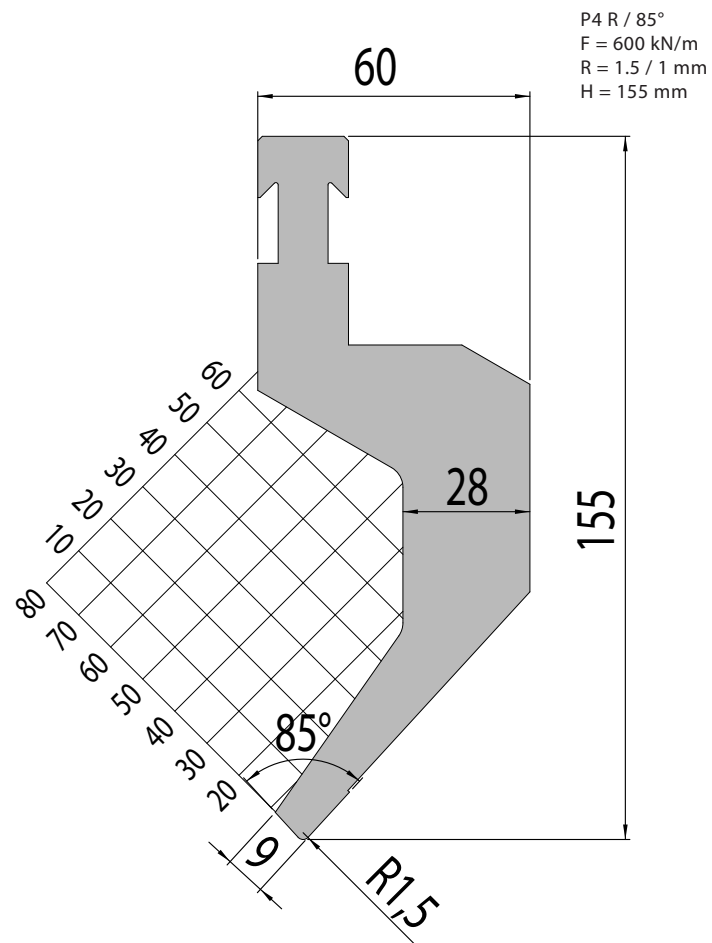

P4 R H250



[R] Radius (mm) 1.5

Nose angle 85°

[H] Height (mm) 250

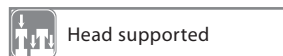
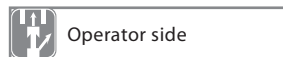
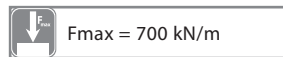
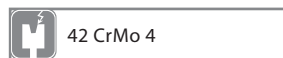

Standard length	Part number
515 mm	65203.0004.5006
1030 mm	65203.0004.3008
1000 mm sect. FSC	65203.0004.0007
Horn set LH + RH	65203.0004.7006

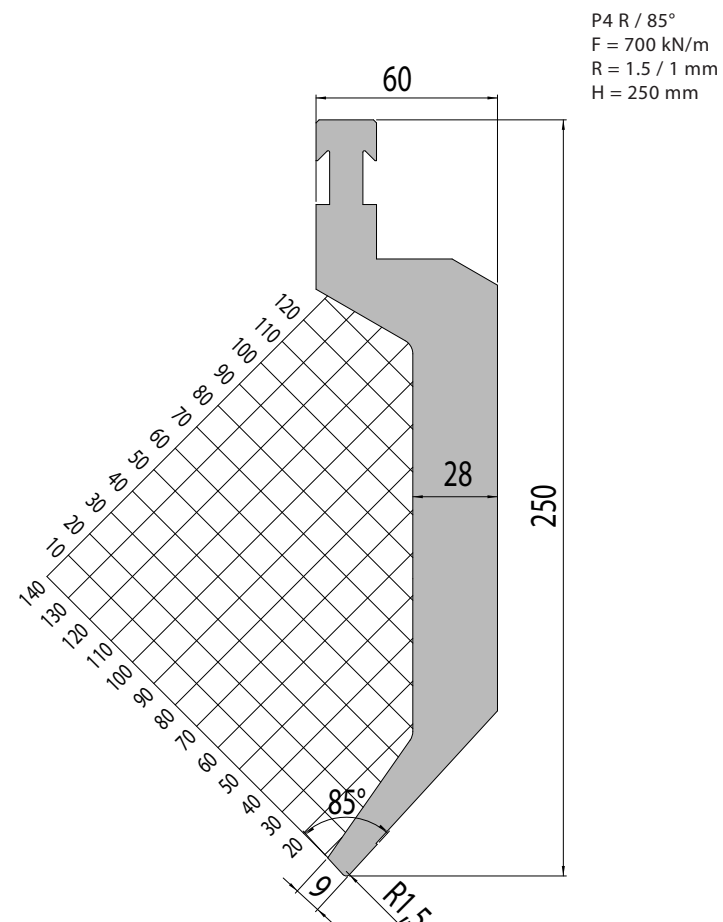

P5 R H155



[R] Radius (mm) 1

Nose angle 30°

[H] Height (mm) 155

 42 CrMo 4

 58 - 62 HRC

 $F_{max} = 1000 \text{ kN/m}$

 Operator side

 Head supported

 16.3 kg/m

 Hydraulic clamping

 57.0 mm

 Ex stock / 24 h

 BOS No. BY1C018

Standard length	Part number
515 mm	65203.0005.5006
1030 mm	65203.0005.3007
1000 mm sect. FSC	65203.0005.0004
Horn set LH + RH	65203.0005.7002

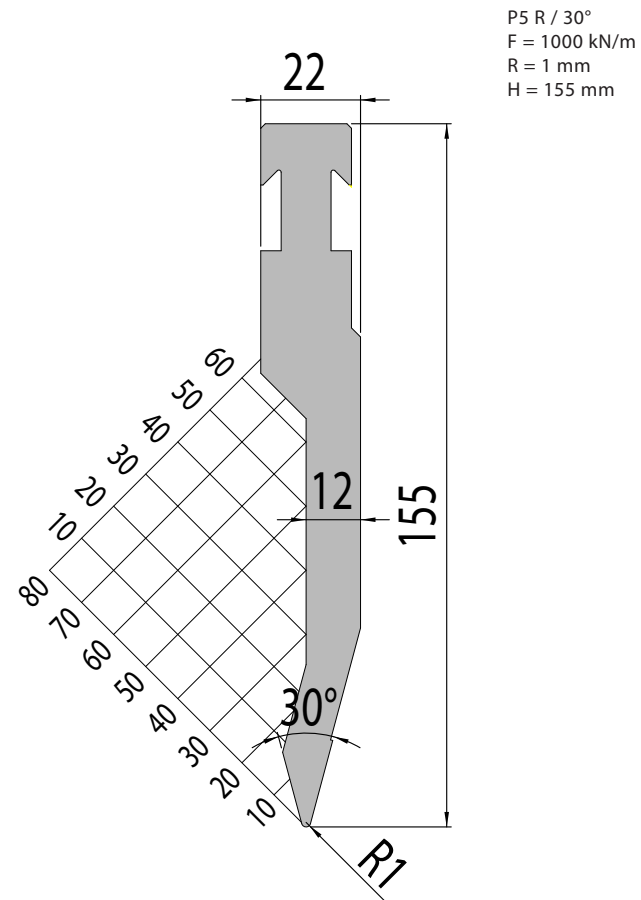

P5 R H250



[R] Radius (mm) 1

Nose angle 30°

[H] Height (mm) 250

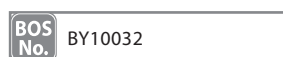
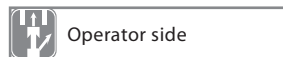
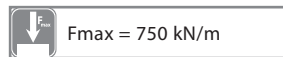
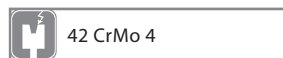

Standard length	Part number
515 mm	65203.0005.5009
1030 mm	65203.0005.3010
1000 mm sect. FSC	65203.0005.0007
Horn set LH + RH	65203.0005.7007

P5 R / 30°
F = 750 kN/m
R = 1 mm
H = 250 mm

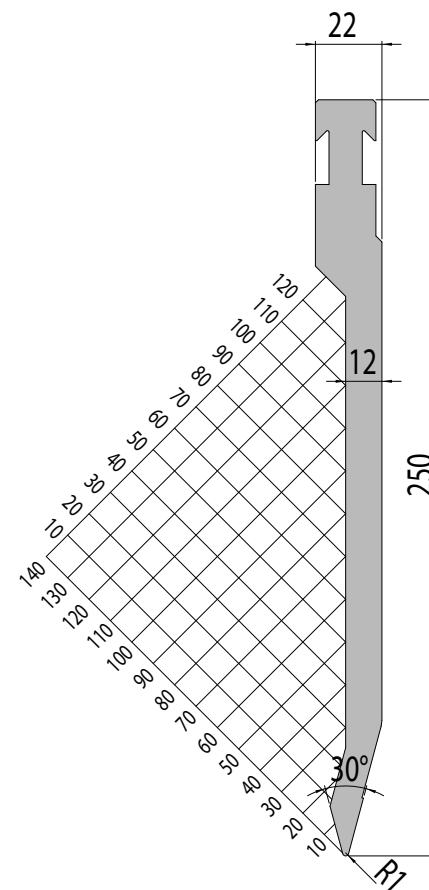

P6 R H155

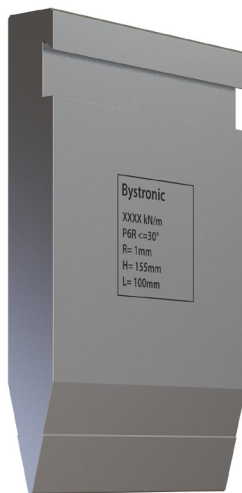



[R] Radius (mm) 1

Nose angle 30°

[H] Height (mm) 155

 42 CrMo 4

 58 - 62 HRC

 F_{max} = 1500 kN/m

 Operator side

 Head supported

 21.1 kg/m

 Hydraulic clamping

 57.0 mm

 Ex stock / 24 h

 BOS No. BY1C022

Standard length	Part number
515 mm	65203.0006.5004
1030 mm	65203.0006.3003
1000 mm sect. FSC	65203.0006.0003
Horn set LH + RH	65203.0006.7002

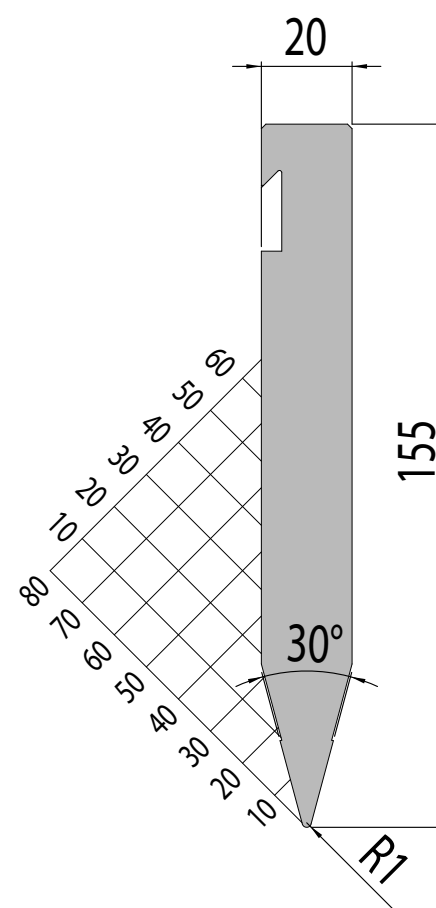

P6 R / 30°
F = 1500 kN/m
R = 1 mm
H = 155 mm

P7 R H155

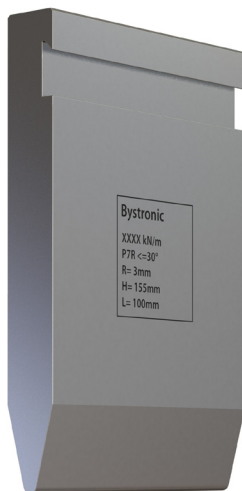

[R] Radius (mm) 3

Nose angle 30°

[H] Height (mm) 155

	42 CrMo 4
	58 - 62 HRC
	F _{max} = 1600 kN/m
	Operator side
	Head supported
	22.0 kg/m
	Hydraulic clamping
	57.0 mm
	Ex stock / 24 h
	BY1C026

Standard length	Part number
515 mm	65206.0007.5002
1030 mm	65206.0007.3004
1000 mm sect. FSC	65206.0007.0003
550 mm sect. FSW	65206.0007.9001
Horn set LH + RH	65206.0007.7001

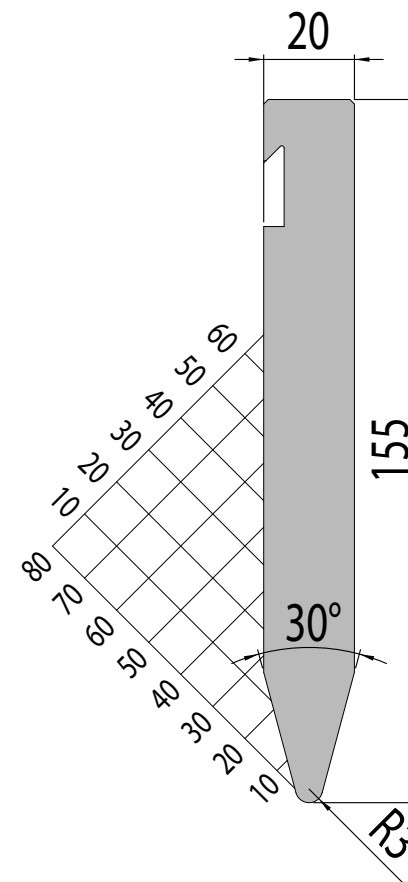

P7 R / 30°
 F = 1600 kN/m
 R = 3 mm
 H = 155 mm

P7 R H250



[R] Radius (mm) 3

Nose angle 30°

[H] Height (mm) 250

 42 CrMo 4

 58 - 62 HRC

 $F_{max} = 1600 \text{ kN/m}$

 Operator side

 Head supported

 36.8kg/m

 Hydraulic clamping

 124.0 mm

 Ex stock / 24 h

 BOS No. BY10258

Standard length	Part number
515 mm	65203.0007.5009
1030 mm	65203.0007.3011
1000 mm sect. FSC	65203.0007.0007
Horn set LH + RH	65203.0007.7003

P7 R / 30°
 $F = 1600 \text{ kN/m}$
 $R = 3 \text{ mm}$
 $H = 250 \text{ mm}$

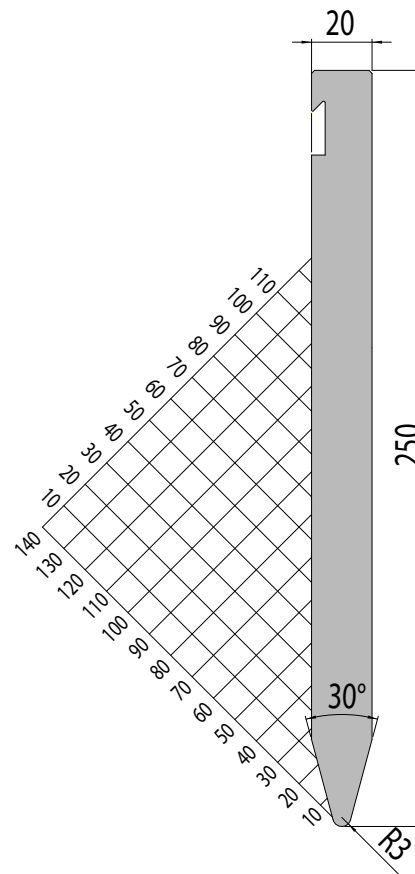

P8 R H155

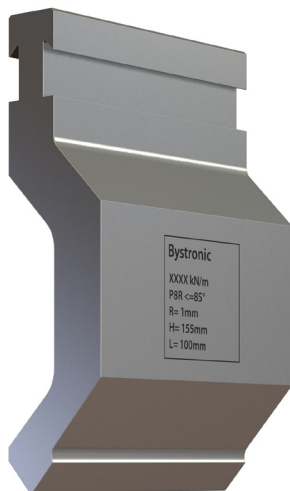

[R] Radius (mm) 1

Nose angle 85°

[H] Height (mm) 155

 42 CrMo 4

 58 - 62 HRC

 $F_{max} = 1000 \text{ kN/m}$

 Operator side

 Head supported

 23.7kg/m

 Hydraulic clamping

 57.0 mm

 Ex stock / 24 h

 BOS No. BY1C030

Standard length	Part number
515 mm	65203.0008.5003
1030 mm	65203.0008.3001
1000 mm sect. FSC	65203.0008.0001
Horn set LH + RH	65203.0008.7002

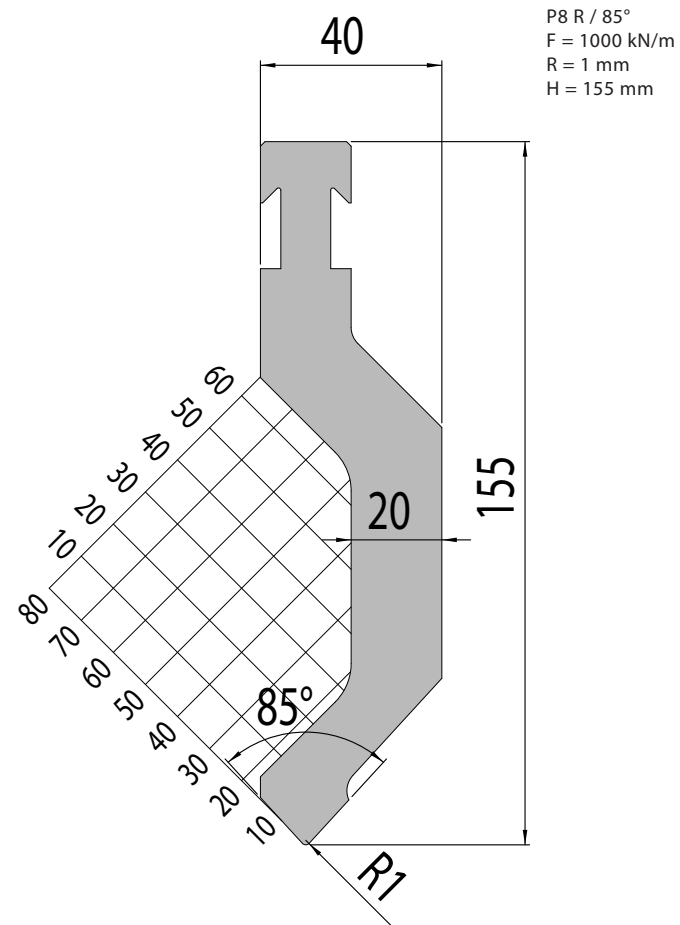

P9 RF-A H155



[R] Radius (mm) 4

Nose angle 60°

[H] High (mm) 155

	42 CrMo 4
	58 - 62 HRC
	F _{max} = 1600 kN/m
	Operator side
	Head supported
	30.5 kg/m
	Hydraulic clamping
	57.0 mm
	Ex stock / 24 h
	BY1C038

Standardlänge	Part number
515 mm	65203.0009.5003
1030 mm	65203.0009.3003
1000 mm sect. FSC	65203.0009.0004
Horn set LH + RH	65203.0009.7001

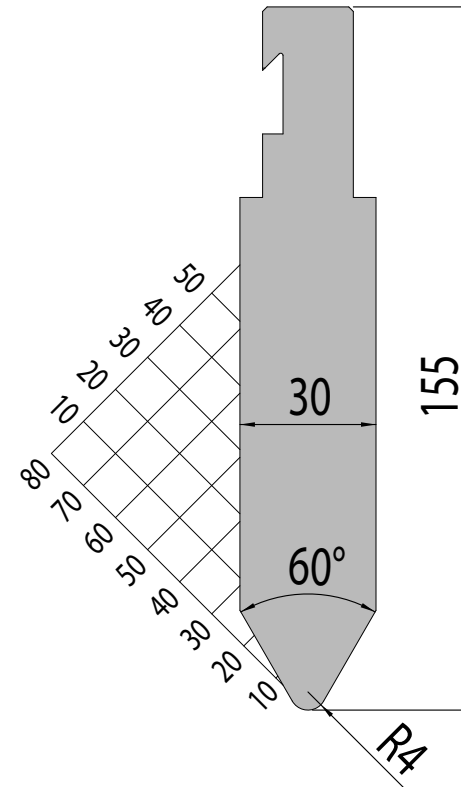

P9 R / 60°
F = 1600 kN/m
R = 4 mm
H = 155 mm

P10 RF-A H130

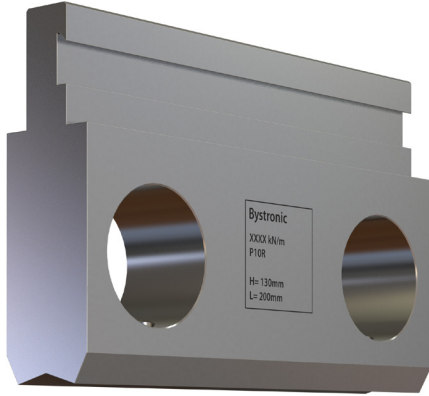

[R] Radius (mm) -

Nose angle -

[H] Height (mm) 130

C45

Fmax = 1600 kN/m

Operator side

Head supported

31.0 kg/m

Hydraulic clamping

Ex stock / 24 h

BOS No. BY1C042

Standard length	Part number
515 mm	65203.0010.5006
1030 mm	65203.0010.3003

P10 RF-A
F = 1600 kN/m
H = 130 mm

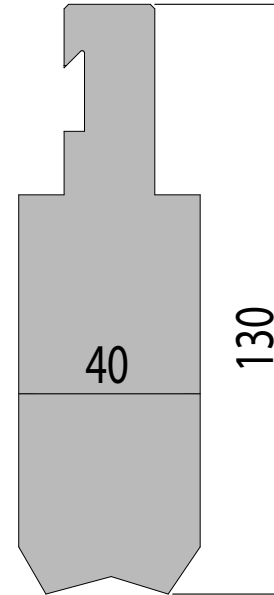

P10 RF-A

Round bars suitable for radius bar holder

Hardened radius bars

L	515/1030	515/1030	515/1030	515/1030	515/1030	515/1030
Type	PB 28	PB 30	PB 35	PB 40	PB 45	PB 50
Ø mm	28	30	35	40	45	50
G	5	5.5	7.5	10	12.5	15.5

515/1030	515/1030	515/1030	515/1030	515/1030
PB 55	PB 60	PB 65	PB 70	PB 80
55	60	65	70	80
18.5	22	26	30	39.5

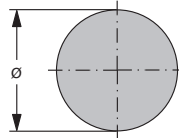

42CrMo4/60 - 62 HRC

Non hardened radius bars of C45 steel (ground) are also available.

P10 RF-A

Round bars suitable for radius bar holder

Length	Ø Round bars	Part number
515 mm	28 mm	65200.0028.5002
	30 mm	65200.0030.5007
	35 mm	65200.0035.5005
	40 mm	65200.0040.5005
	45 mm	65200.0045.5003
	50 mm	65200.0050.5009
	55 mm	65200.0055.5002
	60 mm	65200.0060.5004
	65 mm	65200.0065.5002
1030 mm	28 mm	65200.0028.3002
	30 mm	65200.0030.3007
	35 mm	65200.0035.3002
	40 mm	65200.0040.3006
	45 mm	65200.0045.3002
	50 mm	65200.0050.3005
	55 mm	65200.0055.3001
	60 mm	65200.0060.3004
	65 mm	65200.0065.3001
1030 mm	70 mm	65200.0070.3003
	80 mm	65200.0080.3004

1030 mm	28 mm	65200.0028.3002
	30 mm	65200.0030.3007
	35 mm	65200.0035.3002
	40 mm	65200.0040.3006
	45 mm	65200.0045.3002
	50 mm	65200.0050.3005
	55 mm	65200.0055.3001
	60 mm	65200.0060.3004
	65 mm	65200.0065.3001
1030 mm	70 mm	65200.0070.3003
	80 mm	65200.0080.3004

P11 R H155



[R] Radius (mm) -

Nose angle -

[H] Height (mm) 155

 42 CrMo 4

 58 - 62 HRC

 $F_{max} = 1600 \text{ kN/m}$

 Operator side

 Head supported

 23.8 kg/m

 Hydraulic clamping

 ---

 Ex stock / 24 h

BOS No. BY1C056

Standard length	Part number
515 mm	65203.0011.5002
1030 mm	65203.0011.3003
1000 mm sect.	65203.0011.0001

P11 R
 $F = 1600 \text{ kN/m}$
 $H = 155 \text{ mm}$

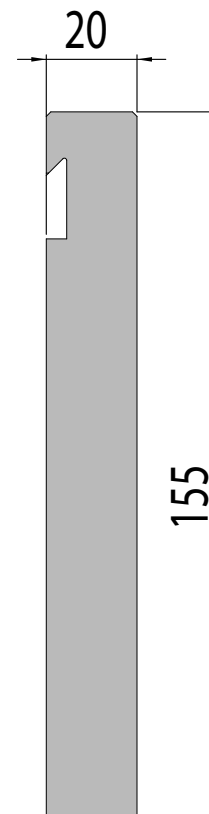

P12 R H110

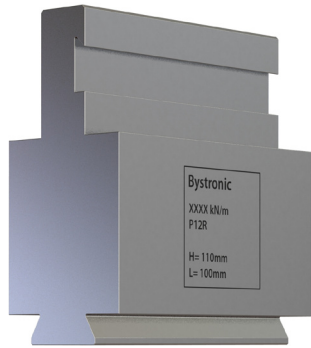

[R] Radius (mm) -

Nose angle -

[H] Height (mm) 110

C45

1600 kN/m

Operator side

Head supported

33 kg/m

Hydraulic clamping

Ex stock / 24 h

BOS No. BY1C060

Standard length	Part number
515 mm	65203.0012.5001
1000 mm sect. FSC	65203.0012.0001

H1 = 44 mm
H2 = 35mm
(standard)

P12 R
F = 1600 kN/m
H = 110 mm

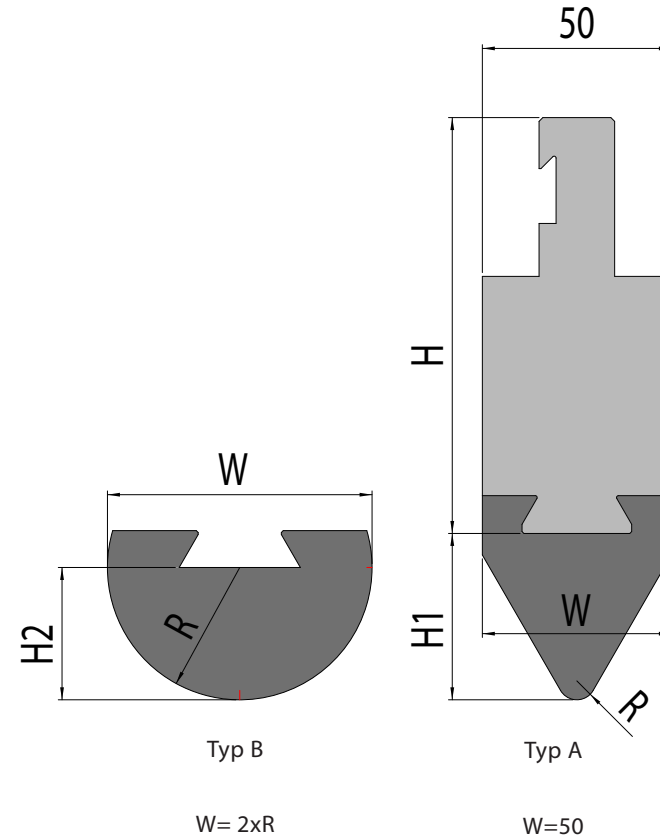

Notes

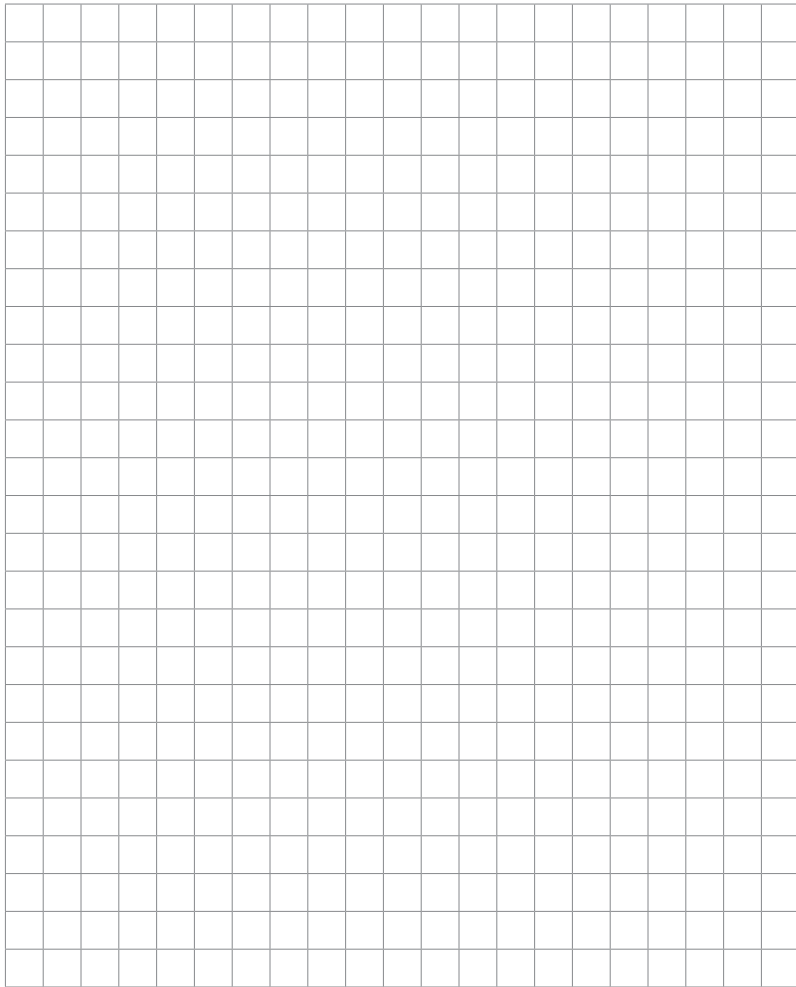

Bottom tools



Lower table options

Tables with mechanical tool clamping

T5
(Standard Xpert 60 – 320)

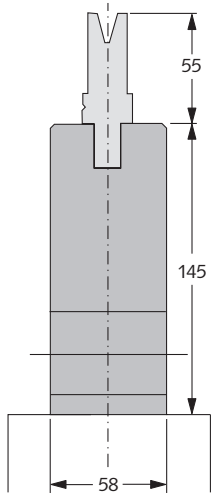

Fitting bottom tools up to V80.

T55
(Standard Xpert 250 – 1000)

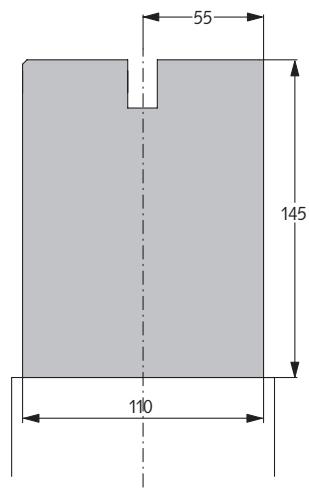

Fitting bottom tools up to V150.

Lower table options

Table with hydraulic tool clamping

T12
(Optional Xpert 60 - 320 and
Xpert 250 - 1000)

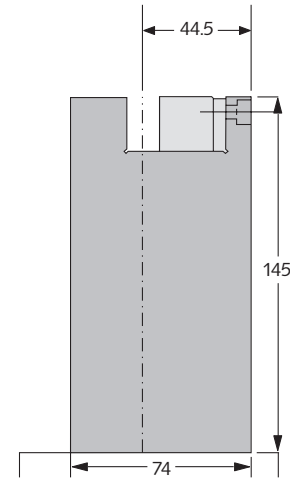

Fitting bottom tools up to V80.

T13
(Optional Xpert 60 - 320 and
Xpert 250 - 1000)

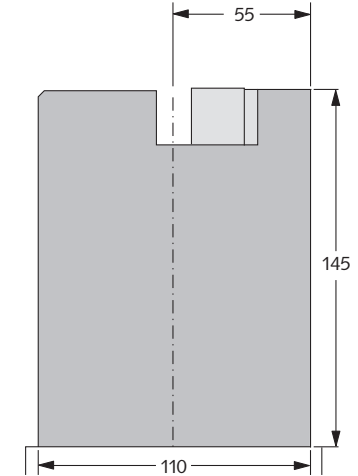

Fitting bottom tools up to V150.

Lower table options

Tables for larger bottom tools

T2
(Standard Xpert MAMMUT and
Optional Xpert 250 - 1000)*

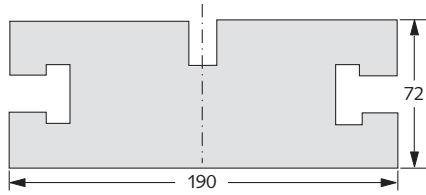

Fitting bottom tools
up to V250.

* this table is ideal to use adapter's (for example S1),
large bottom tools or with V bottom tools.

Lower table options

Hydraulic hemming table with hydraulic die clamping

T9
(Optional for Xpert 60 - 320)

up to 2mm material thickness (mild steel)

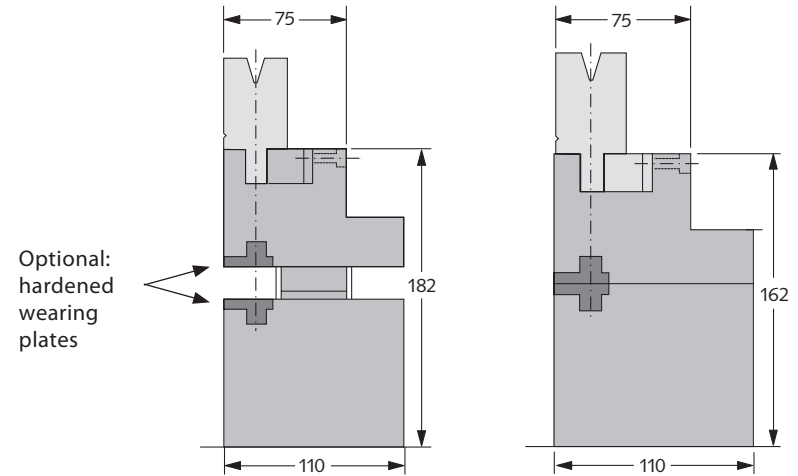

open

closed

Fitting bottom tools up to V60.

This table combines the high productivity of the hydraulic tool clamping
with the flexibility of hemming.

V6/30°

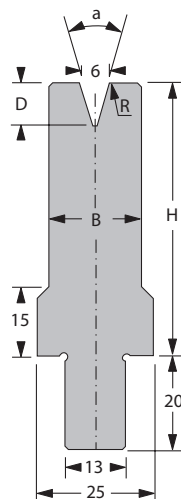

[R] Radius (mm) 0.75

[a] V - Angle 30°

[H] Height (mm) 55

[B] Width (mm) 20

[D] Depth (mm) 9.3

Weight / Meter 10.9 Kg

Standard length	Part number
515 mm	64201.0006.5004
1030 mm	64201.0006.3008
1000 mm sect. FSC	64201.0006.0001

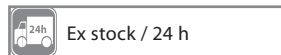
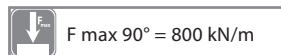
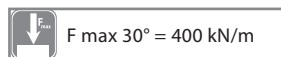
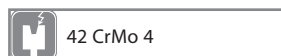

V8/30°

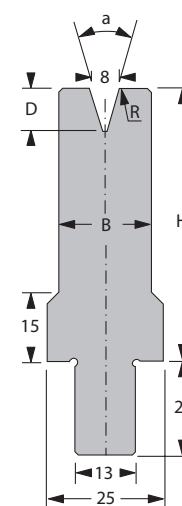

[R] Radius (mm) 1

[a] V - Angle 30°

[H] Height (mm) 55

[B] Width (mm) 20

[D] Depth (mm) 11.2

Weight / Meter 10.8 Kg

Standard length	Part number
515 mm	64201.0008.5012
1030 mm	64201.0008.3005
1000 mm sect. FSC	64201.0008.0001

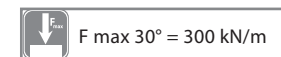
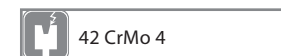

V10/30°

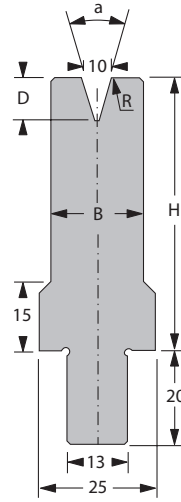

[R] Radius (mm)	1
[a] V - Angle	30°
[H] Height (mm)	55
[B] Width (mm)	20
[D] Depth (mm)	14.9
Weight / Meter	10.6 Kg

Standard length	Part number
515 mm	64201.0010.5016
1030 mm	64201.0010.3006
1000 mm sect. FSC	64201.0010.0004

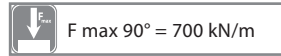
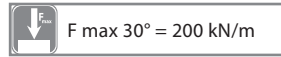

V12/30°

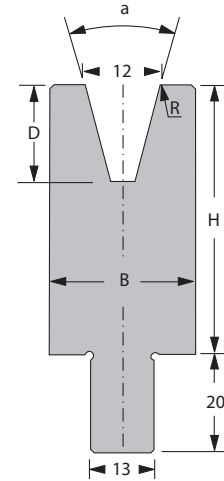

[R] Radius (mm)	1.5
[a] V - Angle	30°
[H] Height (mm)	55
[B] Width (mm)	25
[D] Depth (mm)	18.6
Weight / Meter	11.8 Kg

Standard length	Part number
515 mm	64201.0012.5007
1030 mm	64201.0012.3009
1000 mm sect. FSC	64201.0012.0002

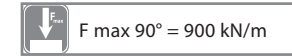
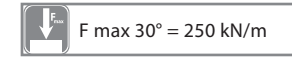

V16/30°

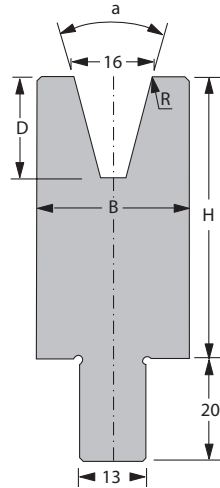

[R] Radius (mm)	2
[a] V - Angle	30°
[H] Height (mm)	55
[B] Width (mm)	30
[D] Depth (mm)	20.5
Weight / Meter	13.3 Kg

Standard length	Part number
515 mm	64201.0016.5011
1030 mm	64201.0016.3006
1000 mm sect. FSC	64201.0016.0001

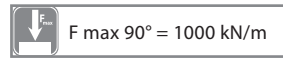
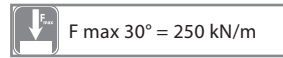

V20/30°

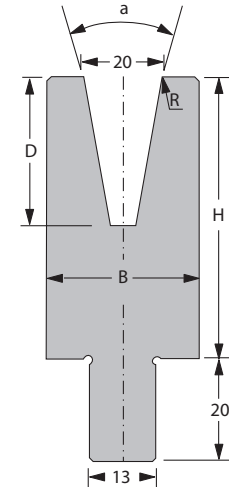

[R] Radius (mm)	2.5
[a] V - Angle	30°
[H] Height (mm)	55
[B] Width (mm)	30
[D] Depth (mm)	28
Weight / Meter	12.2 Kg

Standard length	Part number
515 mm	64201.0020.5002
1030 mm	64201.0020.3007
1000 mm sect. FSC	64201.0020.0002

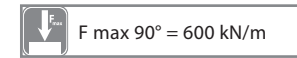
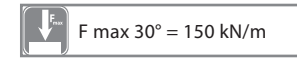

V24/30°

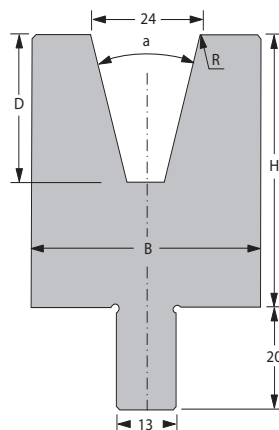

[R] Radius (mm)	3
[a] V - Angle	30°
[H] Height (mm)	55
[B] Width (mm)	40
[D] Depth (mm)	29.8
Weight / Meter	15.5 Kg

Standard length	Part number
515 mm	64201.0024.5010
1030 mm	64201.0024.3005
1000 mm sect. FSC	64201.0024.0001

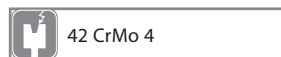

42 CrMo 4



58 - 62 HRC

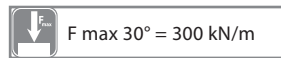

F max 30° = 300 kN/m

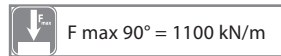

F max 90° = 1100 kN/m



Die insert 13 mm



Ex stock / 24 h



BOS No. BY2C020

V32/30° *

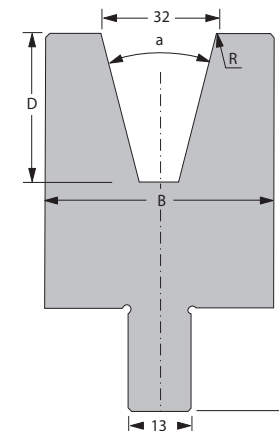
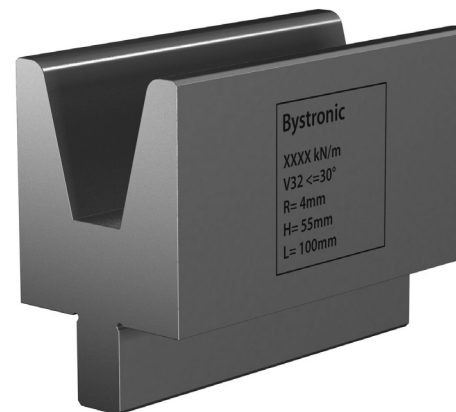

[R] Radius (mm)	4
[a] V - Angle	30°
[H] Height (mm)	55
[B] Width (mm)	48
[D] Depth (mm)	33.6
Weight / Meter	16.7 Kg

Standard length	Part number
515 mm	64201.0032.5010
1030 mm	64201.0032.3006
1000 mm sect. FSC	64201.0032.0002

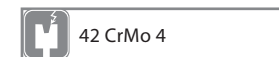

42 CrMo 4

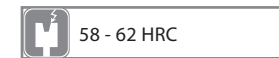

58 - 62 HRC



F max 30° = 300 kN/m



F max 90° = 1100 kN/m



Die insert 13 mm



Ex stock / 24 h



BOS No. BY2C021

* Also available with rolls.

V40/60° *

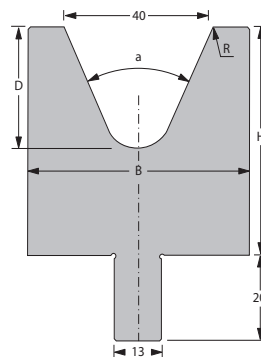

[R] Radius (mm)	5
[a] V - Angle	60°
[H] Height (mm)	55
[B] Width (mm)	55
[D] Depth (mm)	29.6
Weight / Meter	20.5 Kg

Standard length	Part number
515 mm	64201.0040.5003
1030 mm	64201.0040.3007
1000 mm sect. FSC	64201.0040.0002

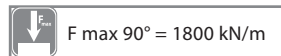
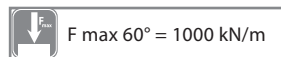

* Also available with rolls.

V50/60° *

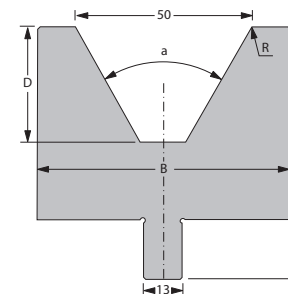

[R] Radius (mm)	5
[a] V - Angle	60°
[H] Height (mm)	55
[B] Width (mm)	70
[D] Depth (mm)	30.3
Weight / Meter	24.5 Kg

Standard length	Part number
515 mm	64201.0050.5003
1030 mm	64201.0050.3003
1000 mm sect. FSC	64201.0050.0001

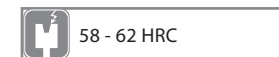
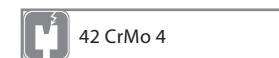

* Also available with rolls.

V60/60° *

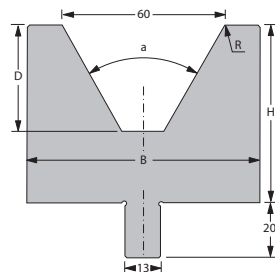

[R] Radius (mm)	7
[a] V - Angle	60°
[H] Height (mm)	65
[B] Width (mm)	80
[D] Depth (mm)	39
Weight / Meter	31.4 Kg

Standard length	Part number
515 mm	64201.0060.5005
1030 mm	64201.0060.3005
1000 mm sect. FSC	64201.0060.0002

* Also available with rolls.

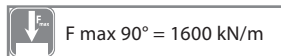
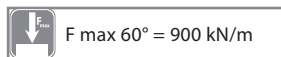
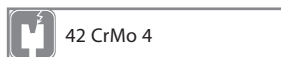

V80/80° *

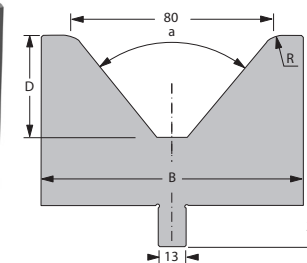
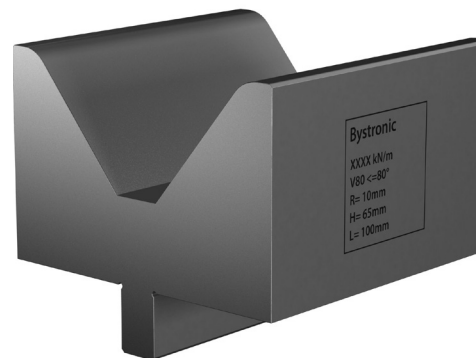

[R] Radius (mm)	10
[a] V - Angle	80°
[H] Height (mm)	65
[B] Width (mm)	100
[D] Depth (mm)	38.7
Weight / Meter	38.6 Kg

Standard length	Part number
515 mm	64201.0080.5002
1030 mm	64201.0080.3005
1000 mm sect. FSC	64201.0080.0001

* Also available with rolls.

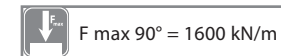
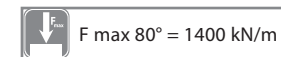
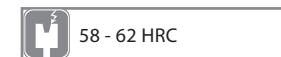
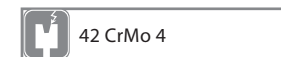

V100/80° *

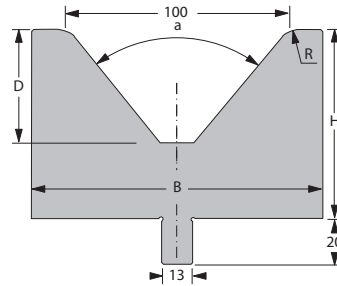
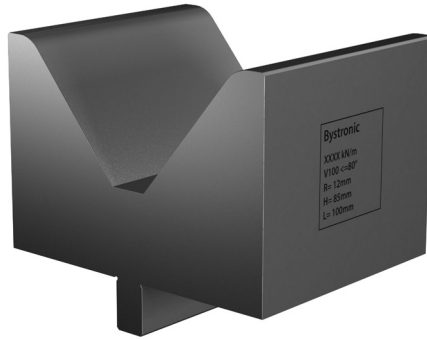

[R] Radius (mm) 12

[a] V - Angle 80°

[H] Height (mm) 85

[B] Width (mm) 125

[D] Depth (mm) 50.5

Weight / Meter 62.5 Kg

Standard length	Part number
515 mm	64201.0100.5004
1030 mm	64201.0100.3005
1000 mm sect. FSC	64201.0100.0001

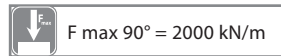
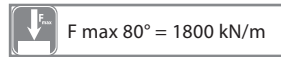

* Also available with rolls.

V120/80° *

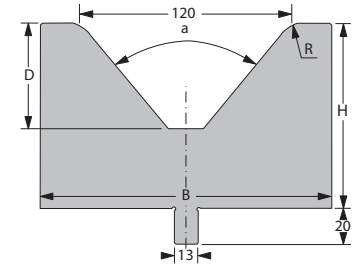

[R] Radius (mm) 15

[a] V - Angle 80°

[H] Height (mm) 105

[B] Width (mm) 160

[D] Depth (mm) 59.5

Weight / Meter 101 Kg

Standard length	Part number
515 mm	64201.0120.5002
1030 mm	64201.0120.3004
1000 mm sect. FSC	64201.0120.0001

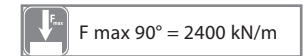
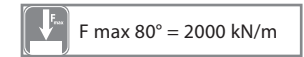

* Also available with rolls.

S1/73

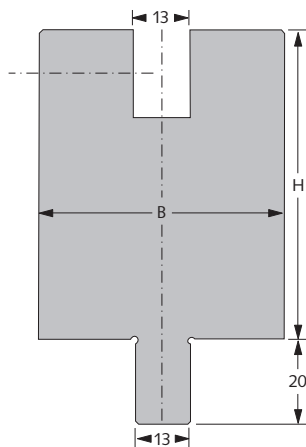

[R] Radius (mm)	-
V - Angle	-
[H] Height (mm)	73
[B] Width (mm)	58
[D] Depth (mm)	22
Weight / Meter	33 Kg

Standard length	Part number
515 mm	64201.0001.5008
1030 mm	64201.0001.3003
1000 mm sect. FSC	64201.0001.0003

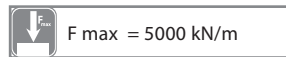

S1/100

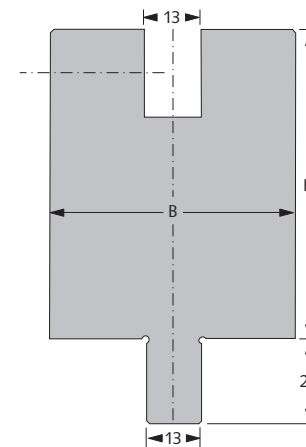

[R] Radius (mm)	-
V - Angle	-
[H] Height (mm)	100
[B] Width (mm)	58
[D] Depth (mm)	22
Weight / Meter	45.3 Kg

Standard length	Part number
515 mm	64201.0001.5006
1030 mm	64201.0001.3004
1000 mm sect. FSC	64201.0001.0001

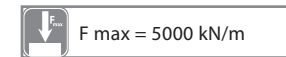

Hemming tools air bending

Hemming tool P900 (upper tool)

P900

$L = 515 / 1030$ $S = 1000 / 1100$ $R = 1$ $\alpha = 30^\circ$

	P900 R			P900 RF			P900 RF-A		
H	175			175			175		
B	6	8	10	6	8	10	6	8	10
G	22	22.8	21	24	24.6	25.2	23	24.4	25
F	500	700	1000	500	700	1000	500	700	1000

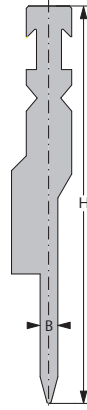

P900 and V900

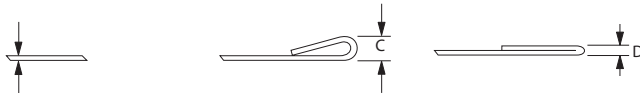

Material thickness mm	Required press force t/m	C mm	Required press force t/m	D mm
0.6	9	3.0	32	1.2
0.8	13	3.0	34	1.6
1.0	15	3.5	36	2.0
1.2	18	3.5	46	2.4
1.6	24	3.5	48	3.2
2.0	42	4.5	52	4.0

L = length (mm)
S = sectionalized (mm)
Z = width (mm)
R = radius (mm)
H = Height (mm)
B = nose width (mm)
W = die opening (mm)
G = weight (kg/m)
F = max. permissible load (kN/m)

Hemming tools air bending

Hemming tool P900 (upper tool)

Mod.	B mm	Z	L mm	Part number
P900.RFA.06	6	14	515	65203.0900.5008
P900.RFA.06	6	14	1030	65203.0900.3006
P900.RFA.06	6	14	1000 S	65203.0900.0006
P900.RFA.08	8	13	515	65203.0900.5002
P900.RFA.08	8	13	1030	65203.0900.3002
P900.RFA.08	8	13	1000 S	65203.0900.0007
P900.RFA.10	10	12	515	65203.0900.5001
P900.RFA.10	10	12	1030	65203.0900.3007
P900.RFA.10	10	12	1000 S	65203.0900.0008
P900.RFA.12	12	11	515	65203.0900.5005
P900.RFA.12	12	11	1030	65203.0900.3008
P900.RFA.12	12	11	1000 S	65203.0900.0003

Loading capacity of the tools (bending forces) P900 + V900:

Pre bending step: 25 t/m

Hemming step: 50 t/m

B= 6 mm -> for sheet thickness up to 1,0 mm

B= 8 mm -> for sheet thickness up to 1,5 mm

B=10 mm -> for sheet thickness up to 2,0 mm

B=12 mm -> for sheet thickness up to 2,3 mm

Hemming tools air bending

Hemming tool V900 (bottom tool)

V900

$L = 515 / 1030$ $S = 1000 / 1100$

V900				
H	85			
W	6	8	10	12
G	36.5	37	38	39
F	500			

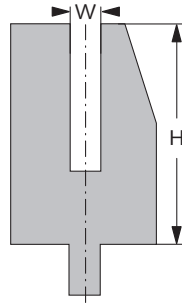

P900 and V900

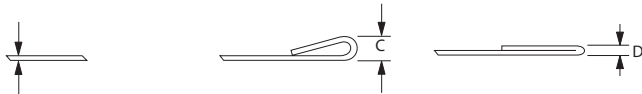

Material thickness mm	Required press force t/m	C mm	Required press force t/m	D mm
0.6	9	3.0	32	1.2
0.8	13	3.0	34	1.6
1.0	15	3.5	36	2.0
1.2	18	3.5	46	2.4
1.6	24	3.5	48	3.2
2.0	42	4.5	52	4.0

L = length (mm)
S = sectionalized (mm)
Z = width (mm)
R = radius (mm)
H = high (mm)
B = nose width (mm)
W = die opening (mm)
G = weight (kg/m)
F = max. permissible load (kN/m)

Hemming tools air bending

Hemming tool V900 (bottom tool)

Mod.	W mm	R mm	L mm	Part number
V900.06	6	1	515	64201.0900.5010
V900.06	6	1	1030	64201.0900.3007
V900.06	6	1	1000 S	64201.0900.0006
V900.08	8	1	515	64201.0900.5005
V900.08	8	1	1030	64201.0900.3003
V900.08	8	1	1000 S	64201.0900.0002
V900.10	10	1	515	64201.0900.5004
V900.10	10	1	1030	64201.0900.3004
V900.10	10	1	1000 S	64201.0900.0004
V900.12	12	1	515	64201.0900.5007
V900.12	12	1	1030	64201.0900.3006
V900.12	12	1	1000 S	64201.0900.0003

Loading capacity of the tools (bending forces) P900 + V900:

Pre bending step: 25 t/m

Hemming step: 50 t/m

B= 6 mm -> for sheet thickness up to 1,0 mm

B= 8 mm -> for sheet thickness up to 1,5 mm

B=10 mm -> for sheet thickness up to 2,0 mm

B=12 mm -> for sheet thickness up to 2,3 mm

Special applications

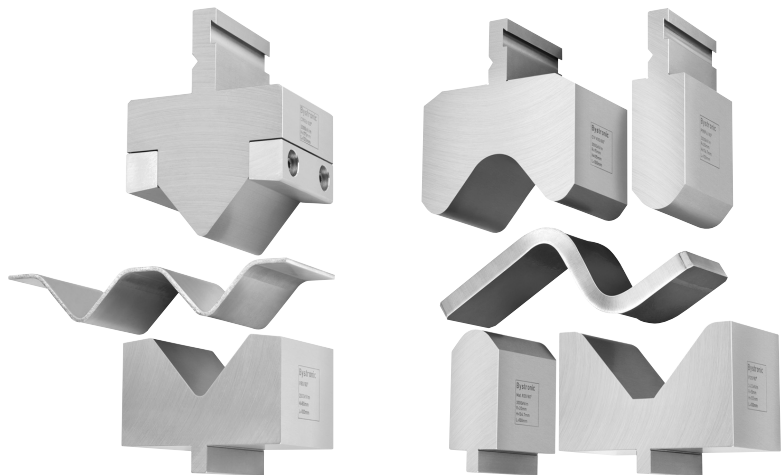

Special applications

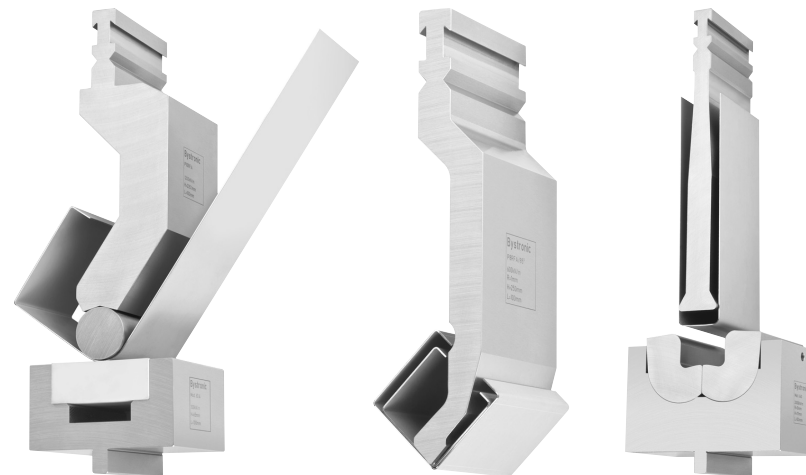

Special tools are also part of the Bystronic tooling range.

Our tooling specialist will help you to solve your forming problems, all contact information are located at the end of the catalog.

Visit our shop in the Internet under: www.bystronic.com

Workshop

Taking bending into design

Small bending radii?
Short flange length?
Too much welding, cleaning and flattening?
Bending marks?



What are the topics?

- Basics
- Software presentations
- Machine presentations
- Industrial design expert talks
- Case studies
- Your questions

You can obtain date and further information from our consulting engineers, all contact dates you can be found on the last page.

Further information can be obtained at: www.bystronic.com

Workshop

Bending of high tensile strength materials

Material costs are too high?
Wear and tear resistance relevant?
Challenge light construction?
Steel broken yet?

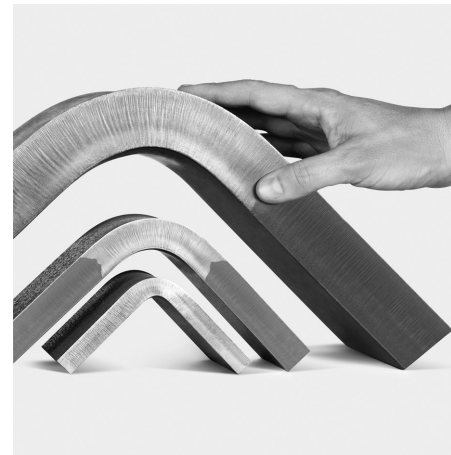

What are the topics?

- Basics
- Experts talks of steel producers
- How the software can help
- Bend case studies
- Specialist talks

You can obtain data and further information from our consulting engineers, all contact data can be found on the last page.

Further information can be obtained at: www.bystronic.com

Bystronic world wide

Bystronic do Brasil Ltda.
Rua Parma 203,
83.413-587 Colombo PR/BR
Brazil
Tel. +55 41 3666 9000
Fax +55 41 3606 8332

Bystronic Canada Ltd.
5730 Coopers Avenue #24
L4Z 2E9 Mississauga
Canada
Tel. +1 905 890 2999
Fax +1 905 890 2998

Bystronic Czech Republic s.r.o.
Turanka 115/1222
627 00 Brno Slatina
Ceská Republika
Tel. +420 532 123 314
Fax +420 532 123 315

Bystronic Co., Ltd (Shanghai)
Level 2, Part A,
No. 999 Huaxu Road Qingpu
China 200702 Shanghai
Tel. +86 21 6082 9300
Fax +86 21 5688 0481

SC Bystronic Laser S.R.L.
Parcu Industrial Pro Roman
Str. Poienilor 5
500419 Brasov
Romania
Tel. +40 268 322140
Fax +40 268 322143

Bystronic Deutschland GmbH
Römerstraße 14
71296 Heimsheim
Deutschland
Tel. +49 7033 4699 0
Fax +49 7033 4699 222

Bystronic Iberica, S.A.
Avenida Tenerife n° 2
Edificio 1, 3a planta, Oficana D
E5-28700 San Sebastián de los
Reyes
Espania
Tel. +34 91 654 48 78
Fax +34 91 652 49 83

Bystronic France S.A.
Park Technopolis,
3 Avenue du Canada
F-91940 Les Ulis
France
Tel. +33 1 69 41 99 84
Fax +33 1 69 41 99 51

Bystronic Laser India (Pvt) Ltd.
7 C, Tadiwala Road
Next to Hotel Panchratna
Pune 411 001
India
Tel. +91 20 67294800
Mobile +91 67294801

Bystronic world wide

Bystronic Italia SRL
Via del Lavoro 30
I-20813 Bovisio Masciago (MB)
Italia
Tel. +39 0362 59 93 1
Fax +39 0362 59 93 209

Bystronic Korea Ltd.
1027-11 Hogye-Dong,
Dongan-Gu,
431-080 Anyang-Si
Korea
Tel. +82 31 389 9800
Fax +82 31 389 9819

Bystronic Mexico S.A. de C.V.
Calle Canes 3250 Int.23,
Col. La Nogalera
44470 Guadalajara
Mexico
Tel. +52 33 3044 0505
Fax +52 33 1380 9979

Bystronic Benelux BV
Stek 8
NL-3371 KG Hardinxveld-
Giessendam
Nederland
Tel. +31 184 611 020
Fax +31 184 617 774

Bystronic Austria GmbH
Salzburger Straße 205
AT-4030 Linz
Österreich
Tel. +43 732 341 155
Fax +43 732 341 153

Bystronic Polska Sp. z o.o.
Sekocin Nowy,
Al. Krakowska 81
PL-05-090 Raszyn
Polska
Tel. +48 22 331 378 2
Fax +48 22 331 377 1

OOO Bystronic Laser
Zorge Street, 9A, building 2
125252 Moscow
Russia
Tel. +7 495 984 71 44
Fax +7 495 984 71 47

Bystronic Sales AG
Industriestrasse 21
CH-3362 Niederönz
Schweiz
Tel. +41 62 956 37 38
Fax +41 62 956 33 81

Bystronic PTE LTD
2 Leng Kee Road #03-05
Thye Hong Centre
Singapore 159086
Tel. +65 6472 6300
Fax +65 6472 6032

Bystronic Scandinavia AB
Metallvägen 30 A
SE-195 72 Rosersberg
Sverige
Tel. +46 8 594 415 50
Fax +46 8 594 415 55

Bystronic Lazer
Barbaros Caddesi K:1 No 66
34775 Ümraniye / Istanbul
Turkey
Tel.: +90 216 464 61 60
Fax: +90 216 464 61 11

Bystronic UK Limited
6 Wayside Business Park
Wilson Lane
Coventry CV6 6NY
United Kingdom
Tel. +44 844 848 5850
Fax +44 844 848 5851

Bystronic Inc.
200 Airport Road
60123-932 Elgin IL
USA
Tel. +1 847 214 0300
Fax +1 847 214 0299

Bystronic Intern. Laser Ltd.
Minsheng Rd., Banqiao Dist.
Rm. 1B, 24F-1, No. 33, Sec. 1
220 New Taipei City
Taiwan
Tel. +886 229 599 699
Fax +886 229 599 698

LLC Bystronic Ukraine
Zhylyanska Street 59
Diplomat Hall, OPffice 207
01033 Kiev
Ukraine
Tel. +380 44 569 74 37
Fax +380 44 569 74 38



Notes

92

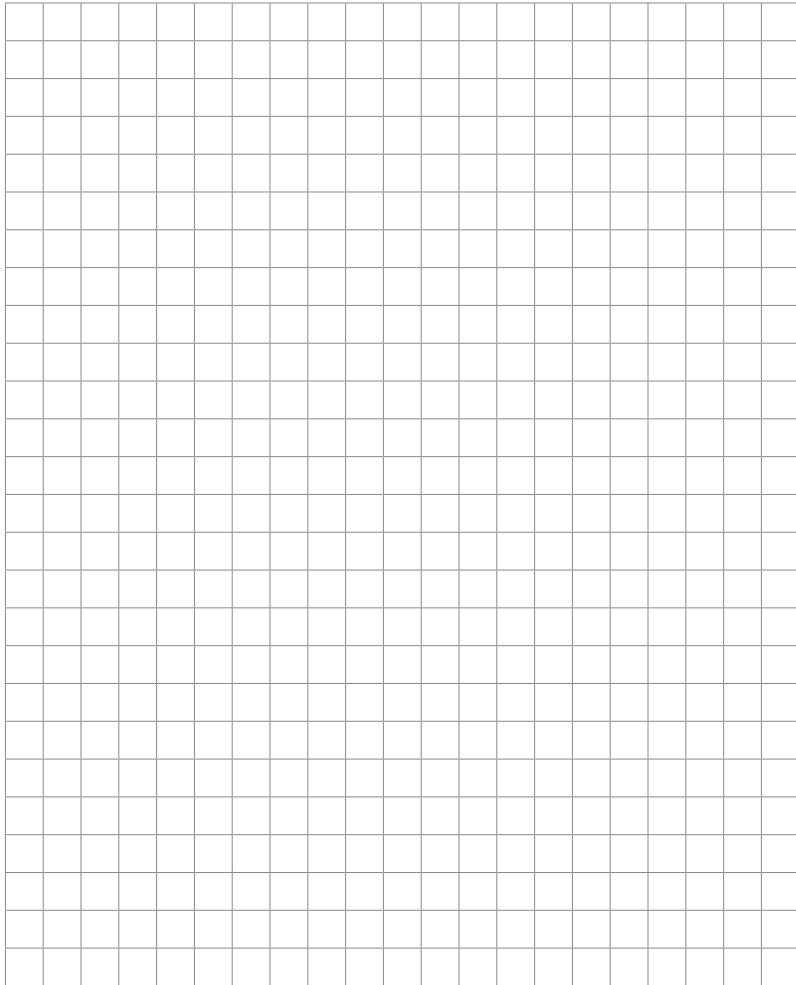

Notes

93

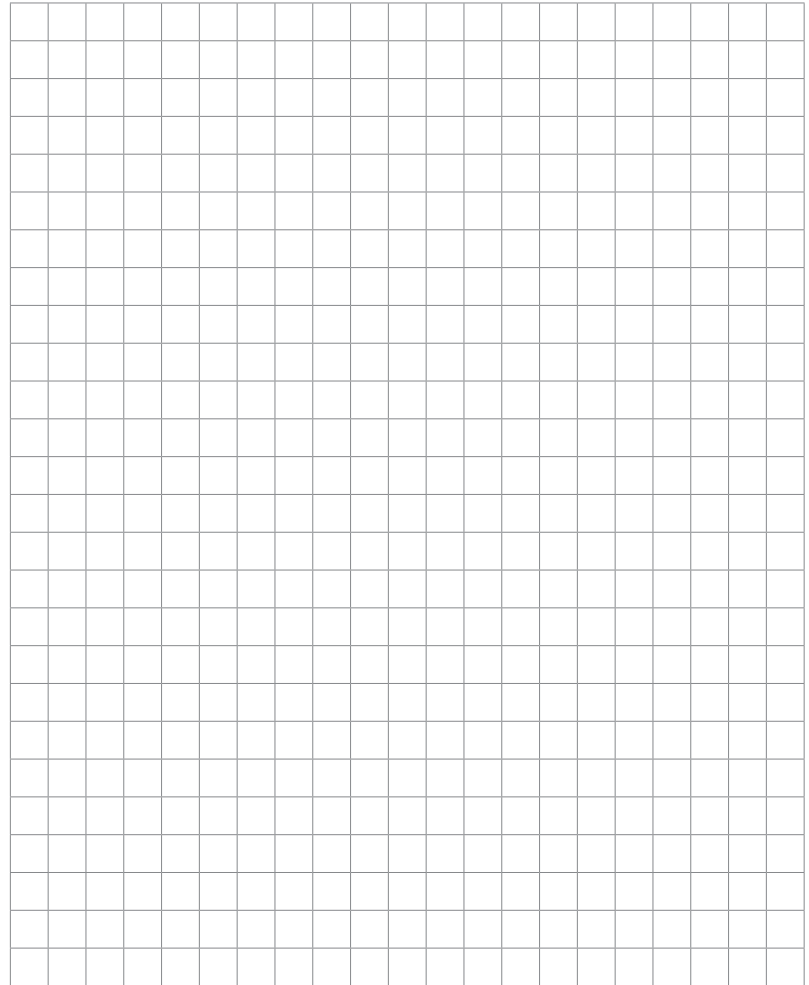

Notes



Notes

