

Best choice.

Cutting. Bending. Automation.

Bystronic

Bystronic-työkalut Työkalumme RF-AC

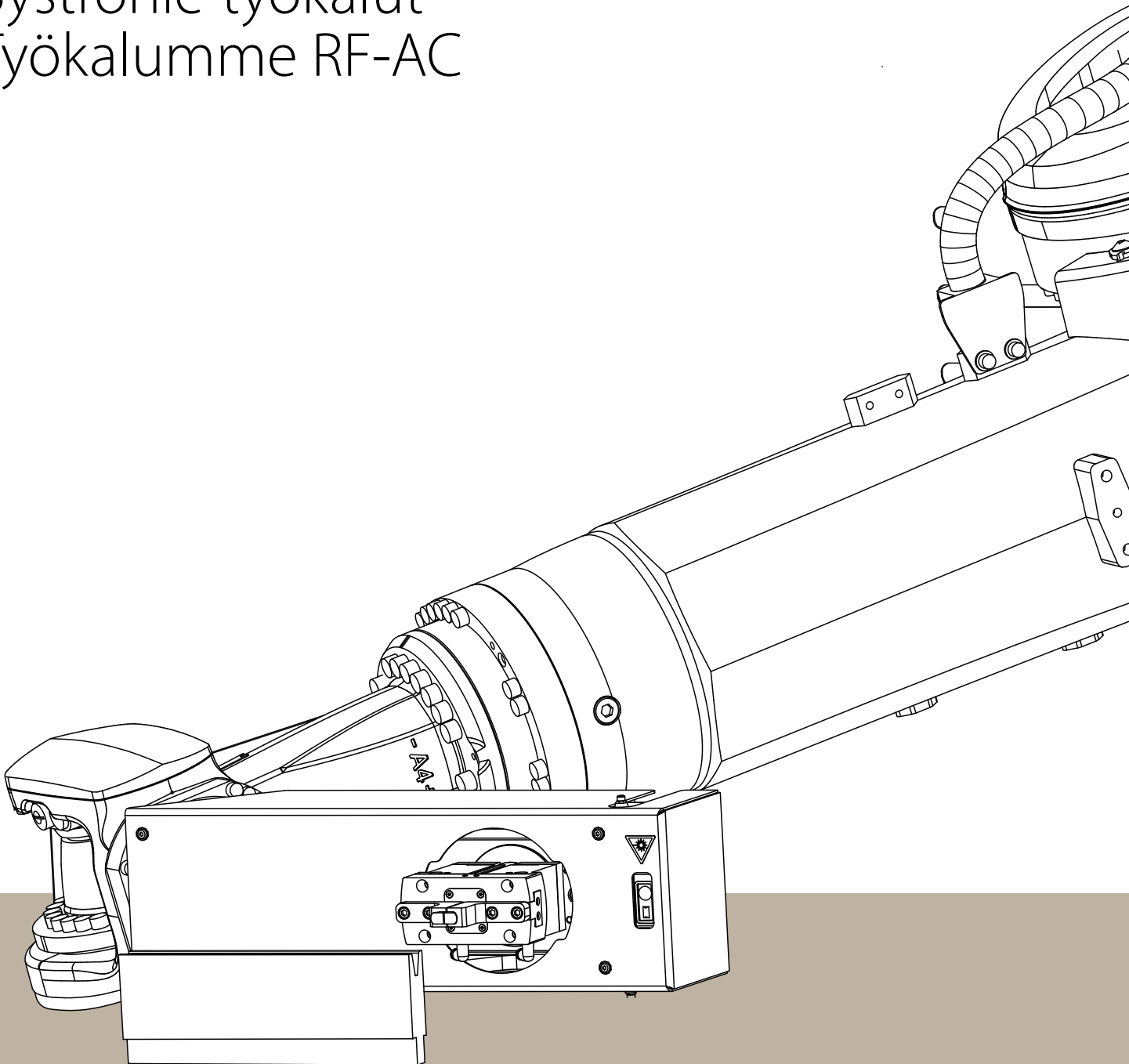



Sisältö

Perustietoa.....	3
Tässä luettelossa käytetyt kuvakkeet.....	3
Ilmasärmäyksen laskentaperusteet.....	4
Miten työkalun vaihto toimii?	8
Lovet.....	9
Segmentoinnit.....	10
Ylätyökalut	14
Ylätyökalusegmentit	16
Alatyökalut	22
Alapöytävaihtoehdot.....	24
Alatyökalujen segmentointi	25
Taittotyökalut.....	60
Yhteystietomme kautta maailman	70



Perustietoa

Tässä luettelossa käytetyt kuvakkeet



Kovuus: 58–62 HRC



Maks. sallittu kuormitus



Maks. kotelosyvyys



Paino



Kääntötyökalu

Tämä luettelo koskee seuraavia koneita:

Xpert Tool Changer - XTC

Modular Tool Changer - MTC

Bending Cell - BC



Ilmasärmäyksen laskentaperusteet

Ilmasärmäyksen kapasiteettitaulukko

Tässä annetut tiedot on laskettu perustuen särmättävään materiaaliin, jonka vetolujuus $R_m = 420 \text{ N/mm}^2$ pituudella 1 m.

V	6	8	10	12	16	18	20	24	32	40	50	60	80
R	1	1.2	1.6	2	2.5	2.8	3	3.5	5	6	8	9.5	12
t	F	Särmäysvoima kN / 1 m:n särmäyspituus											
	a	Laipan minimipituus mm											
0.5	25												
	4.3												
0.8	70	48											
	4.6	5.7											
1	115	80	60										
	5	6	7										
1.2		120	90	70									
		6	7.5	8.5									
1.5			150	120									
			8	9									
2.0				235	160	135	120	95					
				10	12	13	14.5	17					
2.5					265	225	200	155	110				
					12.5	14	15.5	17.5	23				
3.0							300	240	165	125			
							15.5	17.5	23.5	28			
4.0									315	235	180		
									25	29	35		
5.0									535	430	310	250	
									26	31	35.5	43	
6.0										610	450	360	
										32	36	44	
8.0											880	690	470
											40	46	57
10												800	
												60	
12												1200	
												62	
16													
18													
20													

Valssihilseellisten levyjen särmäysvoimaa suurennetaan kertoimella 1.05–1.1



100	120	130	140	150	160	180	190	200	230	260	290	320	V
15.5	19	21	23	24.5	26	28	30	32	36	40	45	50	R
F	Särmäysvoima kN / 1 m:n särmäyspituus												t
a	Laipan minimipituus mm												
													0.5
													0.8
													1
													1.2
													1.5
													2.0
													2.5
													3.0
													4.0
													5.0
													6.0
360													8.0
71													10
600	470	430	390										12
71	85	92	100										16
900	710	650	580	550	500								18
73	86	92	100	105	115								20
	1400	1250	1150	1050	950	810	800	710	600				
	90	98	105	110	115	130	135	140	160				
			1480	1350	1250	1100	1000	950	800	700	600		
			105	110	120	130	135	140	160	180	205		
						1400	1300	1200	1000	900	850	700	
						135	140	145	165	180	205	225	

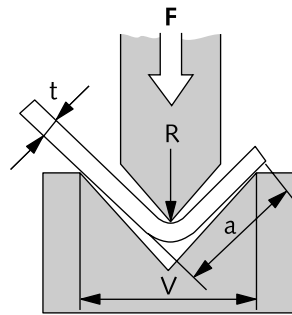

Sisäsäde R vastaa noin 16 prosenttia V-aukkoleveydestä.



Ilmasärmäyksen laskentaperusteet

Laskentakaavat

Ilmasärmäyksessä suositeltu V-aukkoleveys

Materiaalipaksuus	t	0.5–2.5 mm	3–8 mm	9–10 mm	> 12 mm
Aukkoleveys	V	6 × t	8 × t	10 × t	12 × t

Särmäysvoima materiaaleille

Alumiini	R _m = 300 N/mm ²	F = F (taulukko) × 0.65
Pehmeä teräs	R _m = 420 N/mm ²	F = F (taulukko)
Ruostumaton teräs	R _m = 700 N/mm ²	F = F (taulukko) × 1.6

Ilmasärmäyksen särmäysvoiman määrittäminen (referenssitiedot)

$$F = \frac{R_m \times t^2}{V} \times \left(1 + \frac{4 \times t}{V}\right)$$

Muuntaminen: R_m = vetolujuus N/mm²

10 N = 1 kg

10 kN = 1 t

Minimisisäteen R muuntaminen

Paksuus t	1	2	3	4	5	6	8	10	12	16	18	20
min. R	1	2	3	5	6	8	12	16	20	28	36	40



Vetolujuus

Materiaali		Vetolujuus	
Amerikkalainen	Eurooppalainen	KPSI	N/mm ²
6061 alumiini	Alu 50	42	290
5052 alumiini	Alu 35	44	303
1010 pehmeä teräs	DC01	53	366
A536-80 G 60-40-18	GGG-40	58	400
A 351 G CF 8	G-X 6CrNi 18 9	65	450
A 572 G50	S 355 MC	80	550
Domex 80	S 420 MC	80	550
A 36	S 235 JR	80	552
304 ruostumaton	Inox V2A	85	586
316 ruostumaton	Inox V4A	87	600
A 572 G 65	S 460 MC	95	655
Domex 100	S 500 MC	102	700
Domex 550	S 550 MC	110	760
Domex 600	S 600 MC	119	820
Weldox 700	Weldox 700	123	850
Domex 650	S 650 MC	128	880
Domex 700	S 700 MC	138	950
4140 niukkaseosteinen	42 CrMo 4	145	1000
Weldox 900	Weldox 900	149	1030
Weldox 960	Weldox 960	154	1060
Hardox 400	Hardox 400	181	1250
Hardox 500	Hardox 500	225	1550

Suurlujuusmateriaalien särmäyksen osalta ota yhteys myyjään.



Miten työkalun vaihto toimii?

Työkalujen nopean ja tarkan vaihdon nerokas automaatio

- Ylä- ja alatyökalujen automatisoitu vaihto säästää aikaa ja parantaa särmäyslaatua
- Työkalusarjojen tarkka ja virheetön asetus kiinnitysjärjestelmään ylä- ja alapalkissa, myös kookkaat työkalut (jopa V80 / BC ja MTC jopa V120)
- Työkalujen helppo laajennus milloin vain: nerokas tunnistintekniikka tunnistaa automaattisesti uudet työkalut ja integroi ne työkalulippaaseen
- Ylätyökalujen automaattinen kääntö lisää särmäysmahdollisuuksien monipuolisuutta
- Erinomainen ergonomia ja kätevä käsiteltävyys, koska kaikki työkalut ovat valmiina koneessa
- Särmäyspöydän automaattinen puhdistus takaa särmäysosien tarkan ja hellävaraisen käsittelyn



* Työkalun maksimipaino:

Tarrain XTC	- maks. 15.0 kg
Tarrain BC/MTC	- maks. 25.0 kg



Lovet

Ylätyökalut

Ylätyökalujen taustoissa on lovet. Meistit ovat asymmetriset, esim. meisteissä P4 ja P5 on lovet myös etupinnassa.

Meistityyppejä P2, P3, P4, P5, P6, P7, P8, P9, P11 ja P900 korkeudeltaan 250 mm on mahdollista käsitellä. Tilauksesta saatavissa 350 mm korkea.

Segmentointien pituudet ovat välillä 30 mm ja 515 mm*.

Alatyökalut

Alatyökalujen taustoissa on lovi. Sen ansiosta robotti voi käsitellä työkaluja.

Sisämatriisit välillä V6 ja V120 ovat mahdollisia**.

Segmentointien pituudet ovat välillä 50 mm ja 515 mm*.



* Osat noin 515 mm ovat tilauksesta saatavissa tai BC/MTC:hen

** XTC pystyy käsittelemään sisämatriiseja V80 saakka
BC/MTC pystyy käsittelemään sisämatriiseja V120 saakka



Segmentoinnit

koskee Xpert Tool Changer, MTC ja BC

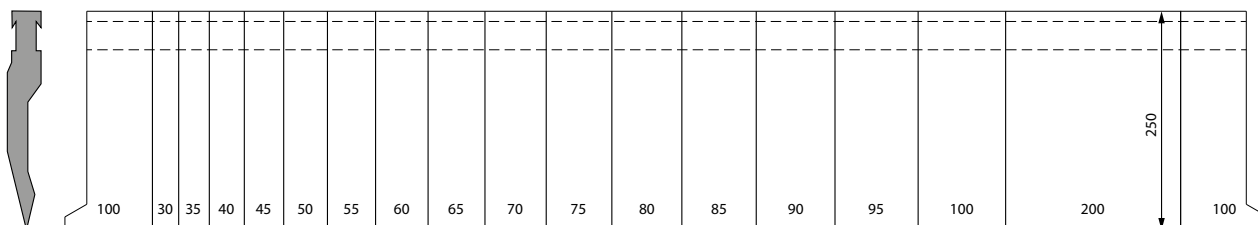

Ylätyökalut	Osanumero
Meisti P2 RF-AC/85° H=250 L=1375 sect.	65208.0002.5000
Meisti P4 RF-AC/85° H=250 L=1375 sect.	65208.0004.5000
Meisti P5 RF-AC/30° H=250 L=1375 sect.	65208.0005.5000
Meisti P7 RF-AC/30° H=250 L=1375 sect.	65208.0007.5000

Kaikki segmentoinnit sisältävät seuraavat pituudet:

30 mm, 35 mm, 40 mm, 45 mm, 50 mm, 55 mm, 60 mm, 65 mm, 70 mm, 75 mm, 80 mm, 85 mm, 90 mm, 95 mm, 100 mm, 200 mm, Horn set 100 mm LH + RH

Ylätyökalut	Osanumero
Meisti P11 RF-AC B=20 H=250 L=1175 sect.	65208.0011.5000

Segmentointi sisältää seuraavat pituudet:

30 mm, 35 mm, 40 mm, 45 mm, 50 mm, 55 mm, 60 mm, 65 mm, 70 mm, 75 mm, 80 mm, 85 mm, 90 mm, 95 mm, 100 mm, 200 mm

Alatyökalut	Osanumero
Sisämatriisi V-Flat B40 L=1025 sect.	65208.0000.5000

Segmentointi sisältää seuraavat pituudet:

50 mm, 55 mm, 60 mm, 65 mm, 70 mm, 75 mm, 80 mm, 85 mm, 90 mm, 95 mm, 100 mm, 200 mm

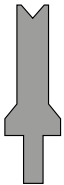

50	55	60	65	70	75	80	85	90	95	100	200

Alatyökalut		Osanumero
Sisämatriisi V6C/30°	L=1025 sect.	64208.0006.5000
Sisämatriisi V8C/30°	L=1025 sect.	64208.0008.5000
Sisämatriisi V10C/30°	L=1025 sect.	64208.0010.5000
Sisämatriisi V12C/30°	L=1025 sect.	64208.0012.5000
Sisämatriisi V16C/30°	L=1025 sect.	64208.0020.5000
Sisämatriisi V20C/30°	L=1025 sect.	64208.0020.5000
Sisämatriisi V24C/30°	L=1025 sect.	64208.0024.5000
Sisämatriisi V32C/30°	L=1025 sect.	64208.0032.5000
Sisämatriisi V40C/60°	L=1025 sect.	64208.0040.5000
Sisämatriisi V50C/60°	L=1025 sect.	64208.0050.5000
Sisämatriisi V60C/60°	L=1025 sect.	64208.0060.5000
Sisämatriisi V80C/80°	L=1025 sect.	64208.0080.5000
Sisämatriisi V100C/80°	L=1025 sect.	64208.0100.5000
Sisämatriisi V120C/80°	L=1025 sect.	64208.0120.5000
Sisämatriisi V6SC/30°	L=1025 sect.	64208.0006.5100
Sisämatriisi V8SC/30°	L=1025 sect.	64208.0008.5100
Sisämatriisi V10SC/30°	L=1025 sect.	64208.0010.5100
Sisämatriisi V12SC/30°	L=1025 sect.	64208.0012.5100

Kaikki segmentoinnit sisältävät seuraavat pituudet:

50 mm, 55 mm, 60 mm, 65 mm, 70 mm, 75 mm, 80 mm, 85 mm, 90 mm, 95 mm, 100 mm, 200 mm

*** Alatyökalut V80 saakka soveltuvat XTC:lle
Alatyökalut V120 saakka soveltuvat BC/MTC:lle**



Segmentoinnit

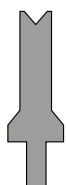

50	55	60	65	70	75	80	85	90	95	100	200

Alatyökalut	Osanumero
Sisämatriisi V6C/30° H=100 L=1025 sect.	64208.0006.5031
Sisämatriisi V8C/30° H=100 L=1025 sect.	64208.0008.5165
Sisämatriisi V10C/30° H=100 L=1025 sect.	64208.0010.5031
Sisämatriisi V12C/30° H=100 L=1025 sect.	64208.0012.5030
Sisämatriisi V16C/30° H=100 L=1025 sect.	64208.0020.5040
Sisämatriisi V20C/30° H=100 L=1025 sect.	64208.0020.5030
Sisämatriisi V24C/30° H=100 L=1025 sect.	64208.0024.5031
Sisämatriisi V32C/30° H=100 L=1025 sect.	64208.0032.5030
Sisämatriisi V40C/60° H=100 L=1025 sect.	64208.0040.5030
Sisämatriisi V50C/60° H=100 L=1025 sect.	64208.0050.5030
Sisämatriisi V60C/60° H=100 L=1025 sect.	64208.0060.5030
Sisämatriisi V80C/80° H=100 L=1025 sect.	64208.0080.5030

Kaikki segmentoinnit sisältävät seuraavat pituudet:

50 mm, 55 mm, 60 mm, 65 mm, 70 mm, 75 mm, 80 mm, 85 mm, 90 mm, 95 mm,
100 mm, 200 mm

* **Alatyökalut V80 saakka soveltuvat XTC:lle**
Alatyökalut V120 saakka soveltuvat BC/MTC:lle





Ylätyökalut

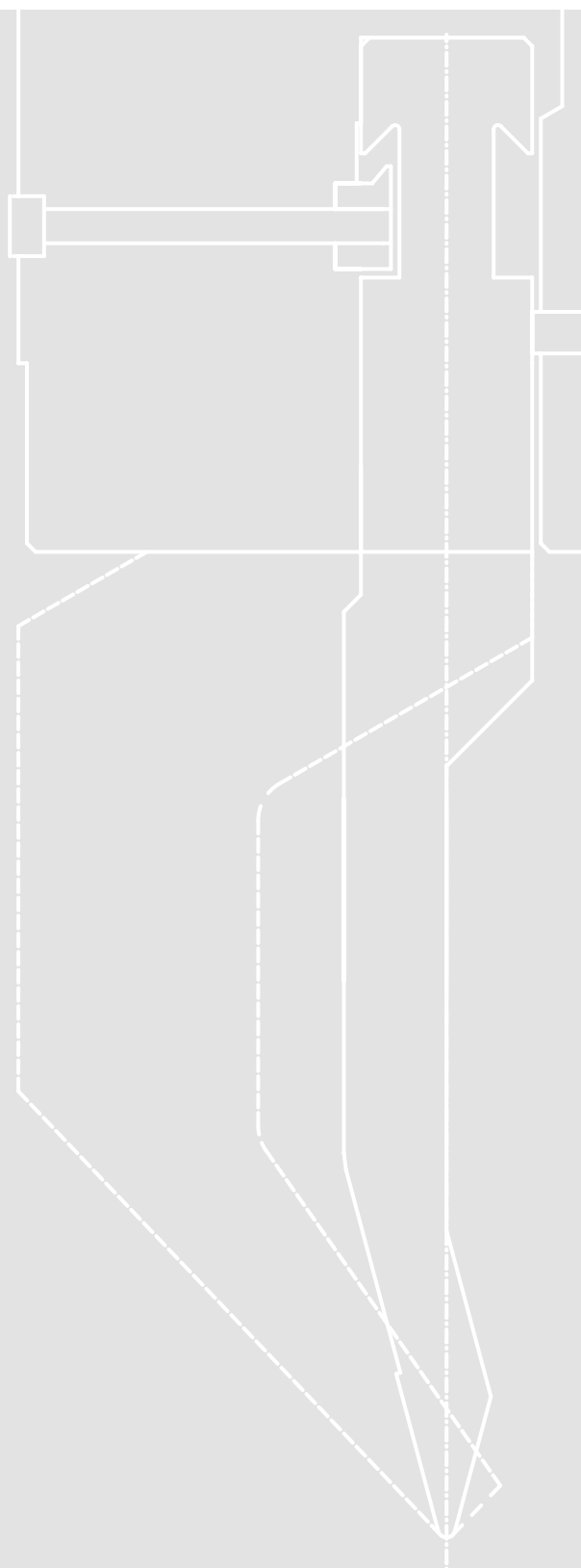





Ylätyökalusegmentit

Sarvet RF-AC

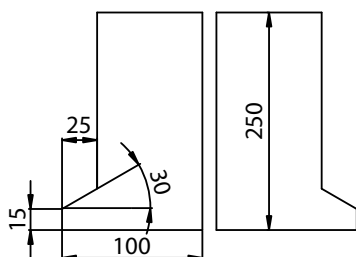

Meisti RF-AC L = 1375 sect.

(30+35+40+45+50+60+65+70+75+80+85+90+95+100+200 +sarvet l+r)

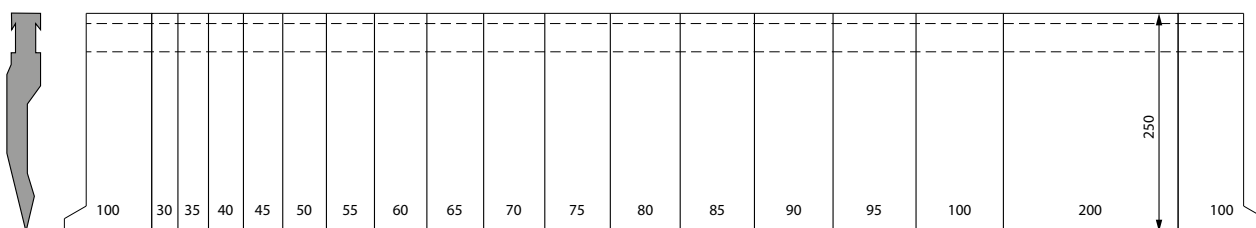

Erityissegmentoinnit tilauksesta.

Kaikki säteeltään muunlaiset ylätyökalut saatavissa tilauksesta.

Työkalun maksimipaino:

Tarrain XTC - maks. 15.0 kg

Tarrain BC/MTC - maks. 25.0 kg



Modular Tool Changer



Bending Cell





P2 RF-AC/85° H250

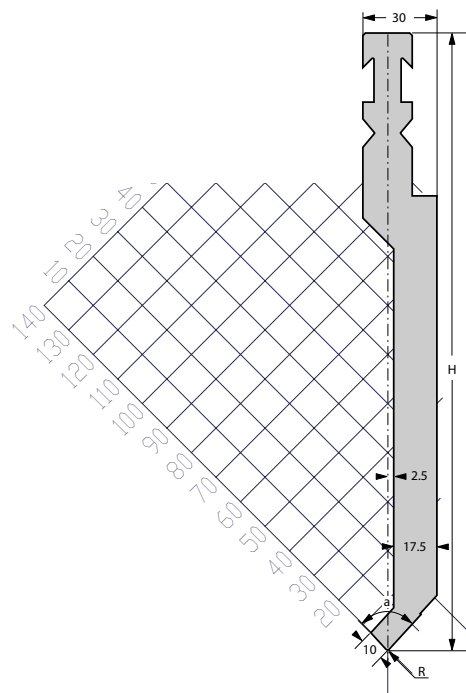

[R] säde (mm)*	1.0
Kärkikulma	85°
[H] korkeus (mm)	250

*Muut säteet tilauksesta

Vakiopituus	Osanumero
30 mm	65208.0002.5001
35 mm	65208.0002.5002
40 mm	65208.0002.5003
45 mm	65208.0002.5004
50 mm	65208.0002.5005
55 mm	65208.0002.5006
60 mm	65208.0002.5007
65 mm	65208.0002.5008
70 mm	65208.0002.5015
75 mm	65208.0002.5016
80 mm	65208.0002.5017

Vakiopituus	Osanumero
85 mm	65208.0002.5018
90 mm	65208.0002.5019
95 mm	65208.0002.5020
100 mm	65208.0002.5011
200 mm	65208.0002.5012
275 mm	65208.0002.5013
300 mm	65208.0002.5014
515 mm	65208.0002.5019
Sarvisarja LH + RH	65208.0002.7001
Sarvi LH	65208.0002.7002
Sarvi RH	65208.0002.7003

F_{max} = 1000 kN/m

34.4 kg/m



98.0 mm



P4 RF-AC/85° H250

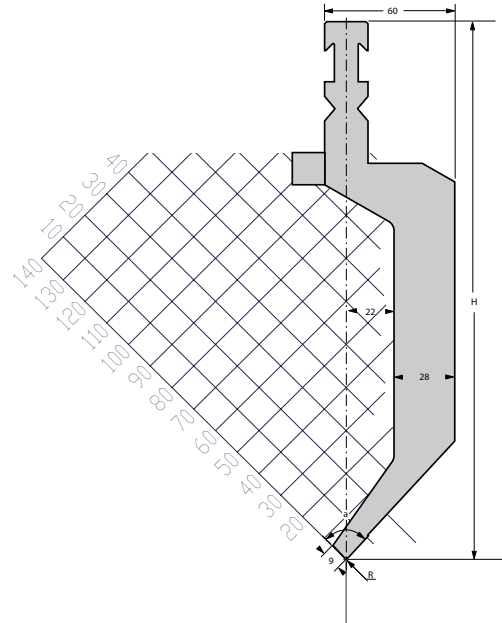

[R] säde (mm)*	1.5
Kärkikulma	85°
[H] korkeus (mm)	250

*Muut säteet tilauksesta

Vakiopituus	Osanumero
30 mm	65208.0004.5001
35 mm	65208.0004.5002
40 mm	65208.0004.5003
45 mm	65208.0004.5004
50 mm	65208.0004.5005
55 mm	65208.0004.5006
60 mm	65208.0004.5007
65 mm	65208.0004.5008
70 mm	65208.0004.5015
75 mm	65208.0004.5016
80 mm	65208.0004.5017

Vakiopituus	Osanumero
85 mm	65208.0004.5018
90 mm	65208.0004.5019
95 mm	65208.0004.5020
100 mm	65208.0004.5011
200 mm	65208.0004.5012
275 mm	65208.0004.5013
300 mm	65208.0004.5014
Sarvisarja LH + RH	65208.0004.7003
Sarvi LH	65208.0004.7001
Sarvi RH	65208.0004.7002



F max = 600 kN/m



48.3 kg/m



98.0 mm



P5 RF-AC/30° H250

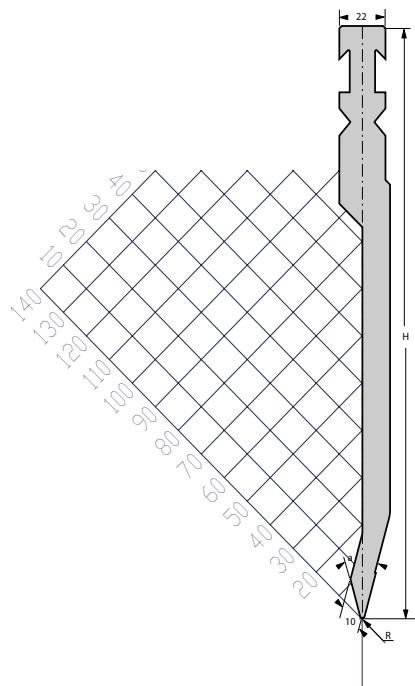

[R] säde (mm)*	1
Kärkikulma	30°
[H] korkeus (mm)	250

*Muut säteet tilauksesta

Vakiopituus	Osanumero
30 mm	65208.0005.5001
35 mm	65208.0005.5002
40 mm	65208.0005.5003
45 mm	65208.0005.5004
50 mm	65208.0005.5005
55 mm	65208.0005.5006
60 mm	65208.0005.5007
65 mm	65208.0005.5008
70 mm	65208.0005.5015
75 mm	65208.0005.5016
80 mm	65208.0005.5017

Vakiopituus	Osanumero
85 mm	65208.0005.5018
90 mm	65208.0005.5019
95 mm	65208.0005.5020
100 mm	65208.0005.5011
200 mm	65208.0005.5012
275 mm	65208.0005.5013
300 mm	65208.0005.5014
515 mm	65208.0005.5021
Sarvisarja LH + RH	65208.0005.7003
Sarvi LH	65208.0005.7001
Sarvi RH	65208.0005.7002

F_{max} = 750 kN/m

26.0 kg/m



98.0 mm



P7 RF-AC/30° H250

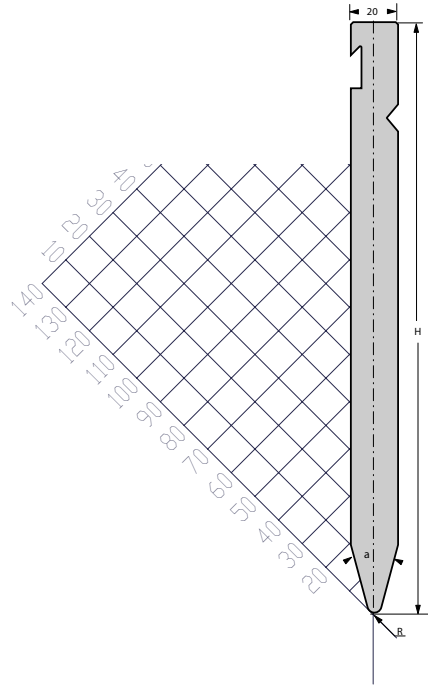

[R] säde (mm)*	3
Kärkikulma	30°
[H] korkeus (mm)	250

*Muut säteet tilauksesta

Vakiopituus	Osanumero
30 mm	65208.0007.5001
35 mm	65208.0007.5002
40 mm	65208.0007.5003
45 mm	65208.0007.5004
50 mm	65208.0007.5005
55 mm	65208.0007.5006
60 mm	65208.0007.5007
65 mm	65208.0007.5008
70 mm	65208.0007.5015
75 mm	65208.0007.5016
80 mm	65208.0007.5017

Vakiopituus	Osanumero
85 mm	65208.0007.5018
90 mm	65208.0007.5019
95 mm	65208.0007.5020
100 mm	65208.0007.5011
200 mm	65208.0007.5012
275 mm	65208.0007.5013
300 mm	65208.0007.5014
515 mm	65208.0007.5026
Sarvisarja LH + RH	65208.0007.7003
Sarvi LH	65208.0007.7001
Sarvi RH	65208.0007.7002



F_{max} = 1400 kN/m



35.9 kg/m²



98.0 mm



Alatyökalut

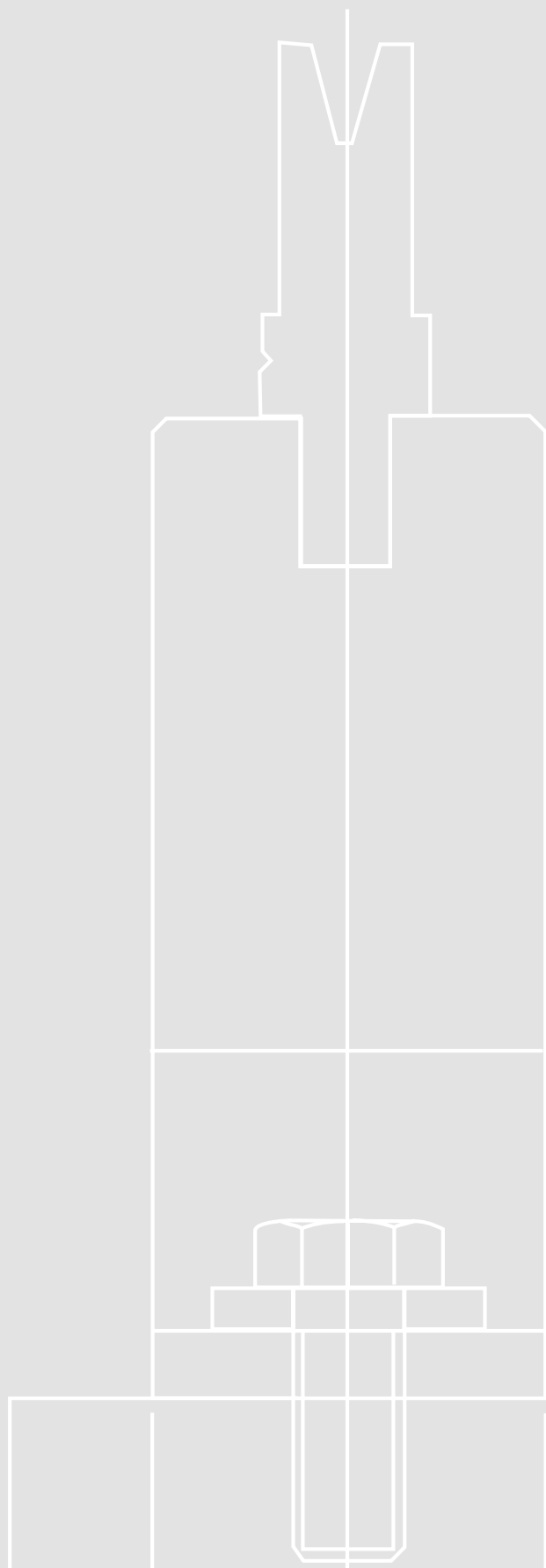





Alapöytävaihtoehdot

Pöytä jossa työkalujen hydrauliset kiinnitysosat

T12

(Lisävaruste Xpert 60 - 320 ja
Xpert 250 - 1000)

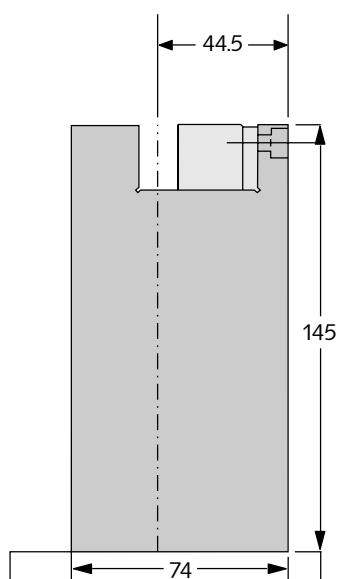

T13

(Lisävaruste Xpert 60 - 320 ja
Xpert 250 - 1000)

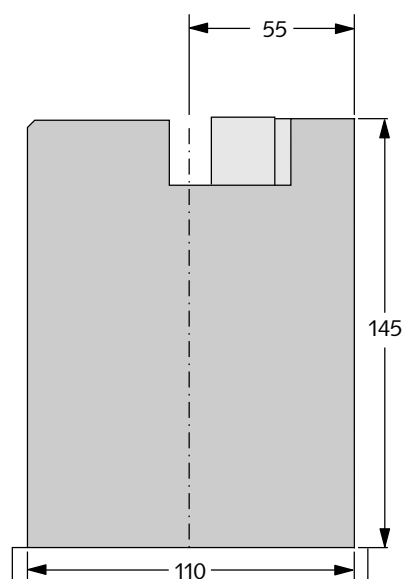



Alatyökalujen segmentointi

Sisämatriisi VC L = 1025 sect.



50	55	60	65	70	75	80	85	90	95	100	200

Erityissegmentoinnit tilauksesta.

Lisäksi kaikkiin alatyökaluihin on saatavissa muokattu säde, meistikulma ja korkeus (vakiomallisista poikkeava).



V6C/30° H55

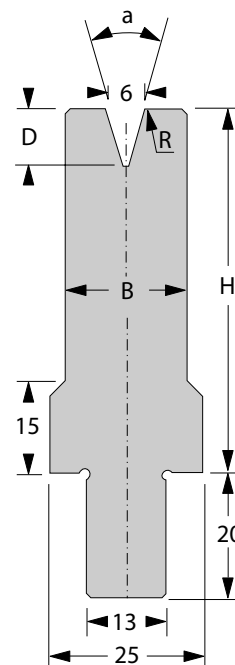

[R] säde (mm)*	0.75
[a] V - kulma	30°
[H] korkeus (mm)	55

[B] leveys (mm)	20
[D] syvyys (mm)	9.3

*Muut säteet tilauksesta

Vakiopituus	Osanumero
50 mm	64208.0006.5001
55 mm	64208.0006.5002
60 mm	64208.0006.5003
65 mm	64208.0006.5004
70 mm	64208.0006.5005
75 mm	64208.0006.5006
80 mm	64208.0006.5007
85 mm	64208.0006.5008
90 mm	64208.0006.5009
95 mm	64208.0006.5010
100 mm	64208.0006.5011

Vakiopituus	Osanumero
200 mm	64208.0006.5012
275 mm	64208.0006.5013
300 mm	64208.0006.5014
515 mm	64208.0006.5015
1025 mm sect.	64208.0006.5000



F max 30° = 400 kN/m



10.9 kg/m



Sisämatriisi 13 mm



V6C/30° H100

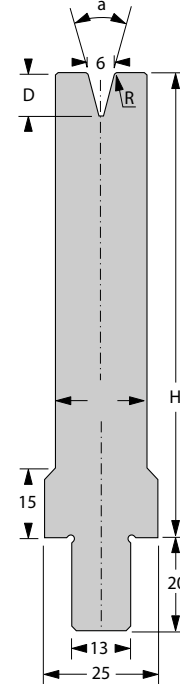

[R] säde (mm)*	0.75
[a] V - kulma	30°
[H] korkeus (mm)	100

[B] leveys (mm)	20
[D] syvyys (mm)	9.3

*Muut säteet tilauksesta

Vakiopituus	Osanumero
50 mm	64208.0006.5016
55 mm	64208.0006.5017
60 mm	64208.0006.5018
65 mm	64208.0006.5019
70 mm	64208.0006.5020
75 mm	64208.0006.5021
80 mm	64208.0006.5022
85 mm	64208.0006.5023
90 mm	64208.0006.5024
95 mm	64208.0006.5025
100 mm	64208.0006.5026

Vakiopituus	Osanumero
200 mm	64208.0006.5027
275 mm	64208.0006.5028
300 mm	64208.0006.5029
515 mm	64208.0006.5030
1025 mm sect.	64208.0006.5031



F max 30° = 400 kN/m



18.0 kg/m



Sisämatriisi 13 mm



V8C/30° H55

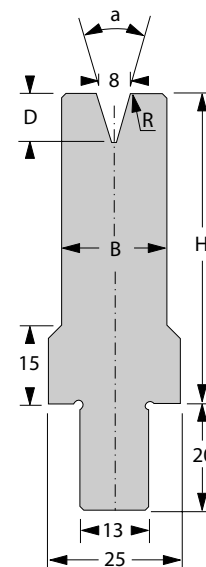

[R] säde (mm)*	1
[a] V - kulma	30°
[H] korkeus (mm)	55

[B] leveys (mm)	20
[D] syvyys (mm)	11.2

*Muut säteet tilauksesta

Vakiopituus	Osanumero
50 mm	64208.0008.5001
55 mm	64208.0008.5002
60 mm	64208.0008.5003
65 mm	64208.0008.5004
70 mm	64208.0008.5005
75 mm	64208.0008.5006
80 mm	64208.0008.5007
85 mm	64208.0008.5008
90 mm	64208.0008.5009
95 mm	64208.0008.5010
100 mm	64208.0008.5011

Vakiopituus	Osanumero
200 mm	64208.0008.5012
275 mm	64208.0008.5013
300 mm	64208.0008.5014
515 mm	64208.0008.5015
1025 mm sect.	64208.0008.5000



F max 30° = 400 kN/m



10.8 kg/m



Sisämatriisi 13 mm



V8C/30° H100

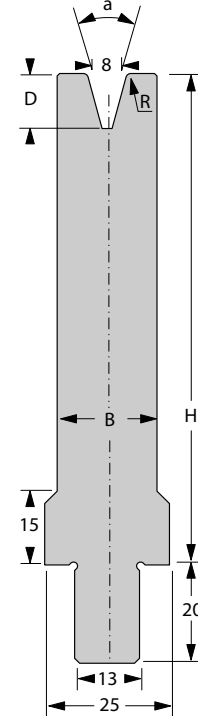

[R] säde (mm)*	1
[a] V - kulma	30°
[H] korkeus (mm)	100

[B] leveys (mm)	20
[D] syvyys (mm)	11.2

*Muut säteet tilauksesta

Vakiopituus	Osanumero
50 mm	64208.0008.5016
55 mm	64208.0008.5017
60 mm	64208.0008.5018
65 mm	64208.0008.5019
70 mm	64208.0008.5020
75 mm	64208.0008.5021
80 mm	64208.0008.5022
85 mm	64208.0008.5023
90 mm	64208.0008.5024
95 mm	64208.0008.5025
100 mm	64208.0008.5026

Vakiopituus	Osanumero
200 mm	64208.0008.5027
275 mm	64208.0008.5028
300 mm	64208.0008.5029
515 mm	64208.0008.5030
1025 mm sect.	64208.0008.5165



F max 30° = 300 kN/m



17.8 kg/m



Sisämatriisi 13 mm



V10C/30° H55

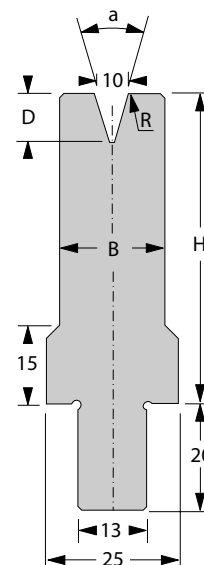
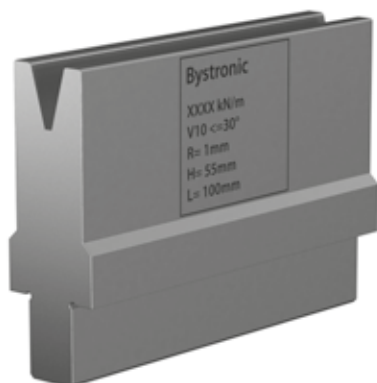

[R] säde (mm)*	1
[a] V - kulma	30°
[H] korkeus (mm)	55

[B] leveys (mm)	20
[D] syvyys (mm)	14.9

*Muut säteet tilauksesta

Vakiopituus	Osanumero
50 mm	64208.0010.5001
55 mm	64208.0010.5002
60 mm	64208.0010.5003
65 mm	64208.0010.5004
70 mm	64208.0010.5005
75 mm	64208.0010.5006
80 mm	64208.0010.5007
85 mm	64208.0010.5008
90 mm	64208.0010.5009
95 mm	64208.0010.5010
100 mm	64208.0010.5011

Vakiopituus	Osanumero
200 mm	64208.0010.5012
275 mm	64208.0010.5013
300 mm	64208.0010.5014
515 mm	64208.0010.5015
1025 mm sect.	64208.0010.5000



F max 30° = 200 kN/m



10.6 kg/m



Sisämatriisi 13 mm



V10C/30° H100

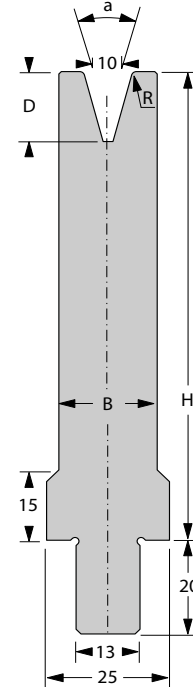

[R] säde (mm)*	1
[a] V - kulma	30°
[H] korkeus (mm)	100

[B] leveys (mm)	20
[D] syvyys (mm)	14.9

*Muut säteet tilauksesta

Vakiopituus	Osanumero
50 mm	64208.0010.5016
55 mm	64208.0010.5017
60 mm	64208.0010.5018
65 mm	64208.0010.5019
70 mm	64208.0010.5020
75 mm	64208.0010.5021
80 mm	64208.0010.5022
85 mm	64208.0010.5023
90 mm	64208.0010.5024
95 mm	64208.0010.5025
100 mm	64208.0010.5026

Vakiopituus	Osanumero
200 mm	64208.0010.5027
275 mm	64208.0010.5028
300 mm	64208.0010.5029
515 mm	64208.0010.5030
1025 mm sect.	64208.0010.5031



F max 30° = 200 kN/m



17.6 kg/m



Sisämatriisi 13 mm



V12C/30° H55

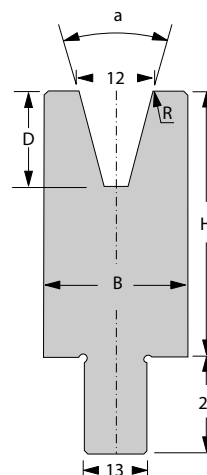

[R] säde (mm)*	1.5
[a] V - kulma	30°
[H] korkeus (mm)	55

[B] leveys (mm)	25
[D] syvyys (mm)	18.6

*Muut säteet tilauksesta

Vakiopituus	Osanumero
50 mm	64208.0012.5001
55 mm	64208.0012.5002
60 mm	64208.0012.5003
65 mm	64208.0012.5004
70 mm	64208.0012.5005
75 mm	64208.0012.5006
80 mm	64208.0012.5007
85 mm	64208.0012.5008
90 mm	64208.0012.5009
95 mm	64208.0012.5010
100 mm	64208.0012.5011

Vakiopituus	Osanumero
200 mm	64208.0012.5012
275 mm	64208.0012.5013
300 mm	64208.0012.5014
515 mm	64208.0012.5015
1025 mm sect.	64208.0012.5000



F max 30° = 250 kN/m



11.8 kg/m



Sisämatriisi 13 mm



V12C/30° H100

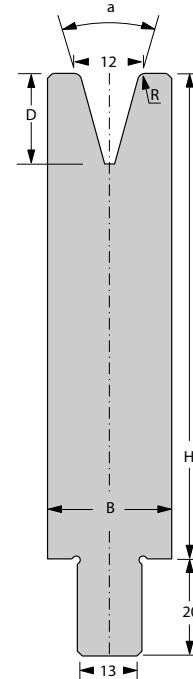

[R] säde (mm)*	1.5
[a] V - kulma	30°
[H] korkeus (mm)	100

[B] leveys (mm)	25
[D] syvyys (mm)	18.6

*Muut säteet tilauksesta

Vakiopituus	Osanumero
50 mm	64208.0012.5017
55 mm	64208.0012.5018
60 mm	64208.0012.5019
65 mm	64208.0012.5020
70 mm	64208.0012.5021
75 mm	64208.0012.5022
80 mm	64208.0012.5023
85 mm	64208.0012.5024
90 mm	64208.0012.5025
95 mm	64208.0012.5026
100 mm	64208.0012.5027

Vakiopituus	Osanumero
200 mm	64208.0012.5028
275 mm	64208.0012.5029
300 mm	64208.0012.5016
515 mm	64208.0012.5031
1025 mm sect.	64208.0012.5030



$F_{max} 30^\circ = 250 \text{ kN/m}$



20.6 kg/m



Sisämatriisi 13 mm



V16C/30° H55

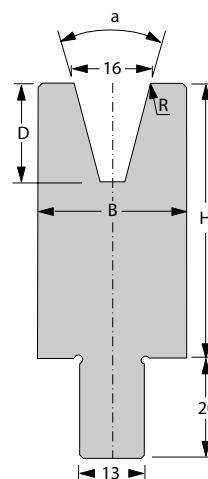

[R] säde (mm)*	2
[a] V - kulma	30°
[H] korkeus (mm)	55

[B] leveys (mm)	30
[D] syvyys (mm)	20.5

*Muut säteet tilauksesta

Vakiopituus	Osanumero
50 mm	64208.0016.5001
55 mm	64208.0016.5002
60 mm	64208.0016.5003
65 mm	64208.0016.5004
70 mm	64208.0016.5005
75 mm	64208.0016.5006
80 mm	64208.0016.5007
85 mm	64208.0016.5008
90 mm	64208.0016.5009
95 mm	64208.0016.5010
100 mm	64208.0016.5011

Vakiopituus	Osanumero
200 mm	64208.0016.5012
275 mm	64208.0016.5013
300 mm	64208.0016.5014
515 mm	64208.0016.5015
1025 mm sect.	64208.0016.5000



F max 30° = 250 kN/m



13.3 kg/m



Sisämatriisi 13 mm



V16C/30° H100

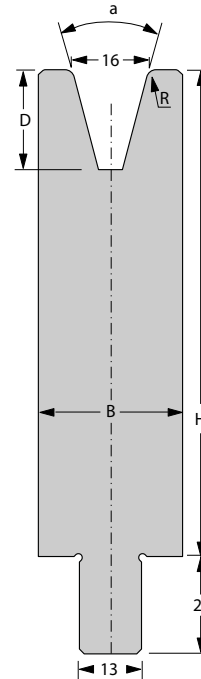

[R] säde (mm)*	2
[a] V - kulma	30°
[H] korkeus (mm)	100

[B] leveys (mm)	30
[D] syvyys (mm)	20.5

*Muut säteet tilauksesta

Vakiopituus	Osanumero
50 mm	64208.0016.5016
55 mm	64208.0016.5017
60 mm	64208.0016.5018
65 mm	64208.0016.5019
70 mm	64208.0016.5020
75 mm	64208.0016.5021
80 mm	64208.0016.5022
85 mm	64208.0016.5023
90 mm	64208.0016.5024
95 mm	64208.0016.5025
100 mm	64208.0016.5026

Vakiopituus	Osanumero
200 mm	64208.0016.5027
275 mm	64208.0016.5028
300 mm	64208.0016.5029
515 mm	64208.0016.5030
1025 mm sect.	64208.0016.5040



F max 30° = 250 kN/m



23.9 kg/m



Sisämatriisi 13 mm



V20C/30° H55

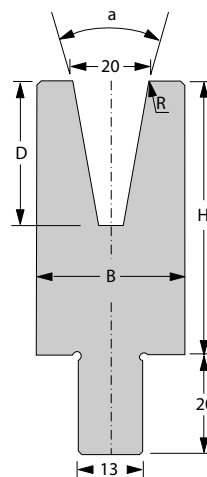

[R] säde (mm)*	2.5
[a] V - kulma	30°
[H] korkeus (mm)	55

[B] leveys (mm)	30
[D] syvyys (mm)	28

*Muut säteet tilauksesta

Vakiopituus	Osanumero
50 mm	64208.0020.5001
55 mm	64208.0020.5002
60 mm	64208.0020.5003
65 mm	64208.0020.5004
70 mm	64208.0020.5005
75 mm	64208.0020.5006
80 mm	64208.0020.5007
85 mm	64208.0020.5008
90 mm	64208.0020.5009
95 mm	64208.0020.5010
100 mm	64208.0020.5011

Vakiopituus	Osanumero
200 mm	64208.0020.5012
275 mm	64208.0020.5013
300 mm	64208.0020.5014
515 mm	64208.0020.5015
1025 mm sect.	64208.0020.5000



F max 30° = 150 kN/m



12.2 kg/m



Sisämatriisi 13 mm



V20C/30° H100

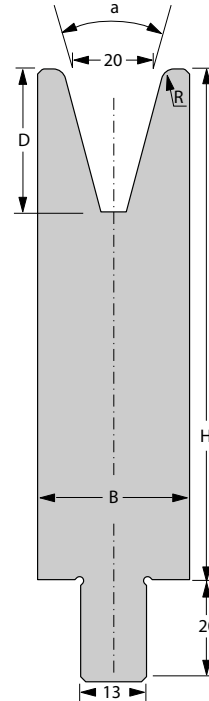

[R] säde (mm)*	2.5
[a] V - kulma	30°
[H] korkeus (mm)	100

[B] leveys (mm)	30
[D] syvyys (mm)	28

*Muut säteet tilauksesta

Vakiopituus	Osanumero
50 mm	64208.0020.5017
55 mm	64208.0020.5018
60 mm	64208.0020.5019
65 mm	64208.0020.5020
70 mm	64208.0020.5021
75 mm	64208.0020.5022
80 mm	64208.0020.5023
85 mm	64208.0020.5024
90 mm	64208.0020.5025
95 mm	64208.0020.5026
100 mm	64208.0020.5027

Vakiopituus	Osanumero
200 mm	64208.0020.5028
275 mm	64208.0020.5029
300 mm	64208.0020.5016
515 mm	64208.0020.5031
1025 mm sect.	64208.0020.5030



F max 30° = 150 kN/m



22.8 kg/m



Sisämatriisi 13 mm



V24C/30° H55

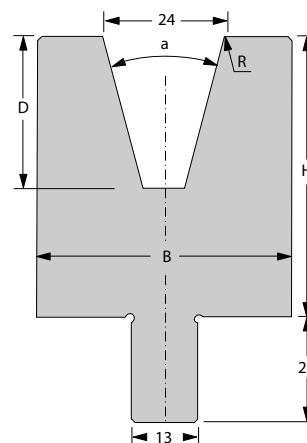

[R] säde (mm)*	3
[a] V - kulma	30°
[H] korkeus (mm)	55

[B] leveys (mm)	40
[D] syvyys (mm)	29.8

*Muut säteet tilauksesta

Vakiopituus	Osanumero
50 mm	64208.0024.5001
55 mm	64208.0024.5002
60 mm	64208.0024.5003
65 mm	64208.0024.5004
70 mm	64208.0024.5005
75 mm	64208.0024.5006
80 mm	64208.0024.5007
85 mm	64208.0024.5008
90 mm	64208.0024.5009
95 mm	64208.0024.5010
100 mm	64208.0024.5011

Vakiopituus	Osanumero
200 mm	64208.0024.5012
275 mm	64208.0024.5013
300 mm	64208.0024.5014
515 mm	64208.0024.5015
1025 mm sect.	64208.0024.5000



F max 30° = 300 kN/m



15.5 kg/m



Sisämatriisi 13 mm



V24C/30° H100

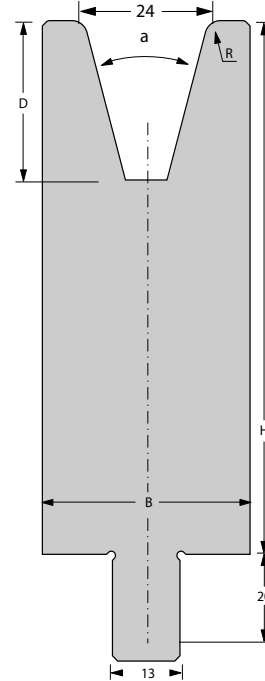

[R] säde (mm)*	3
[a] V - kulma	30°
[H] korkeus (mm)	100

[B] leveys (mm)	40
[D] syvyys (mm)	29.8

*Muut säteet tilauksesta

Vakiopituus	Osanumero
50 mm	64208.0024.5016
55 mm	64208.0024.5017
60 mm	64208.0024.5018
65 mm	64208.0024.5019
70 mm	64208.0024.5020
75 mm	64208.0024.5021
80 mm	64208.0024.5022
85 mm	64208.0024.5023
90 mm	64208.0024.5024
95 mm	64208.0024.5025
100 mm	64208.0024.5026

Vakiopituus	Osanumero
200 mm	64208.0024.5027
275 mm	64208.0024.5028
300 mm	64208.0024.5029
515 mm	64208.0024.5030
1025 mm sect.	64208.0024.5031



F max 30° = 300 kN/m



29.6 kg/m



Sisämatriisi 13 mm



V32C/30° H55

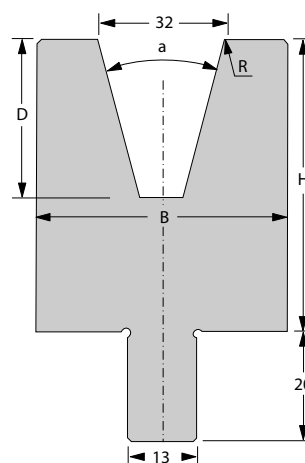
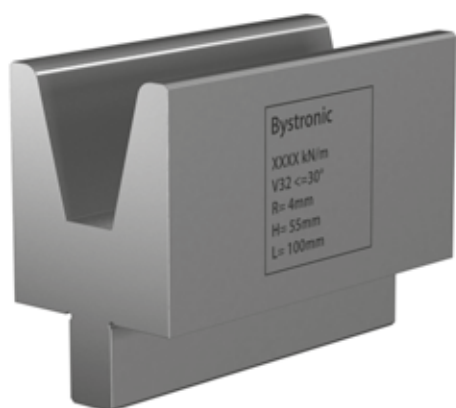

[R] säde (mm)*	4
[a] V - kulma	30°
[H] korkeus (mm)	55

[B] leveys (mm)	48
[D] syvyys (mm)	33.6

*Muut säteet tilauksesta

Vakiopituus	Osanumero
50 mm	64208.0032.5001
55 mm	64208.0032.5002
60 mm	64208.0032.5003
65 mm	64208.0032.5004
70 mm	64208.0032.5005
75 mm	64208.0032.5006
80 mm	64208.0032.5007
85 mm	64208.0032.5008
90 mm	64208.0032.5009
95 mm	64208.0032.5010
100 mm	64208.0032.5011

Vakiopituus	Osanumero
200 mm	64208.0032.5012
275 mm	64208.0032.5013
300 mm	64208.0032.5014
515 mm	64208.0032.5015
1025 mm sect.	64208.0032.5000



F max 30° = 300 kN/m



16.7 kg/m



Sisämatriisi 13 mm



V32C/30° H100

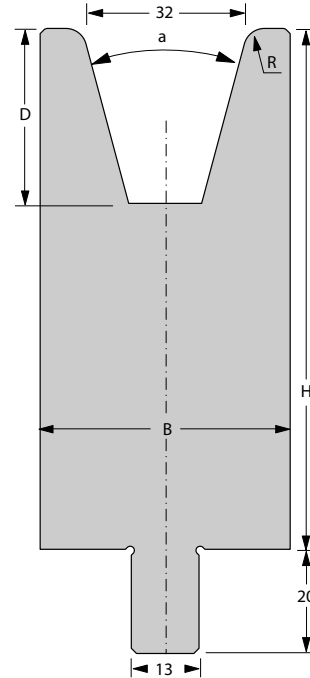

[R] säde (mm)*	4
[a] V - kulma	30°
[H] korkeus (mm)	100

[B] leveys (mm)	48
[D] syvyys (mm)	33.6

*Muut säteet tilauksesta

Vakiopituus	Osanumero
50 mm	64208.0032.5017
55 mm	64208.0032.5018
60 mm	64208.0032.5019
65 mm	64208.0032.5020
70 mm	64208.0032.5021
75 mm	64208.0032.5022
80 mm	64208.0032.5023
85 mm	64208.0032.5024
90 mm	64208.0032.5025
95 mm	64208.0032.5026
100 mm	64208.0032.5027

Vakiopituus	Osanumero
200 mm	64208.0032.5028
275 mm	64208.0032.5029
300 mm	64208.0032.5016
515 mm	64208.0032.5031
1025 mm sect.	64208.0032.5030



F max 30° = 300 kN/m



33.7 kg/m



Sisämatriisi 13 mm



V40C/60° H55

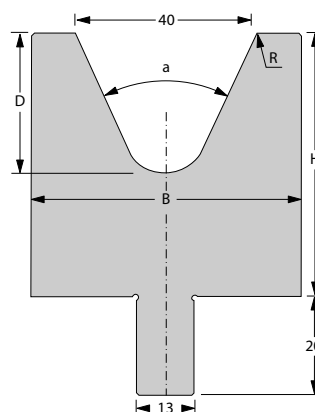
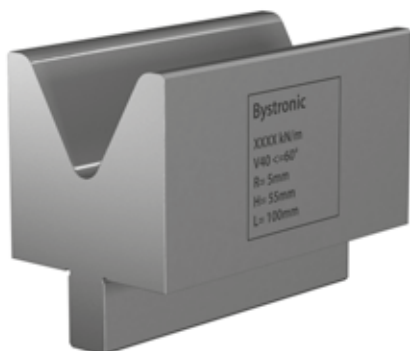

[R] säde (mm)*	5
[a] V - kulma	60°
[H] korkeus (mm)	55

[B] leveys (mm)	55
[D] syvyys (mm)	29.6

*Muut säteet tilauksesta

Vakiopituus	Osanumero
50 mm	64208.0040.5001
55 mm	64208.0040.5002
60 mm	64208.0040.5003
65 mm	64208.0040.5004
70 mm	64208.0040.5005
75 mm	64208.0040.5006
80 mm	64208.0040.5007
85 mm	64208.0040.5008
90 mm	64208.0040.5009
95 mm	64208.0040.5010
100 mm	64208.0040.5011

Vakiopituus	Osanumero
200 mm	64208.0040.5012
275 mm	64208.0040.5013
300 mm	64208.0040.5014
515 mm	64208.0040.5015
1025 mm sect.	64208.0040.5000



F max 60° = 1800 kN/m



20.5 kg/m



Sisämatriisi 13 mm



V40C/60° H100

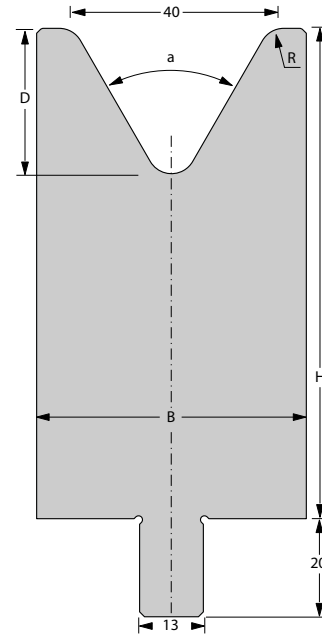

[R] säde (mm)*	5
[a] V - kulma	60°
[H] korkeus (mm)	100

[B] leveys (mm)	55
[D] syvyys (mm)	29.6

*Muut säteet tilauksesta

Vakiopituus	Osanumero
50 mm	64208.0040.5017
55 mm	64208.0040.5018
60 mm	64208.0040.5019
65 mm	64208.0040.5020
70 mm	64208.0040.5021
75 mm	64208.0040.5022
80 mm	64208.0040.5023
85 mm	64208.0040.5024
90 mm	64208.0040.5025
95 mm	64208.0040.5026
100 mm	64208.0040.5027

Vakiopituus	Osanumero
200 mm	64208.0040.5028
275 mm	64208.0040.5029
300 mm	64208.0040.5016
515 mm	64208.0040.5031
1025 mm sect.	64208.0040.5030



$F_{max} 60^\circ = 1300 \text{ kN/m}$



39.9 kg/m



Sisämatriisi 13 mm



V50C/60° H55

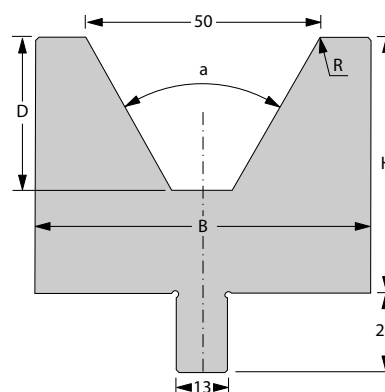
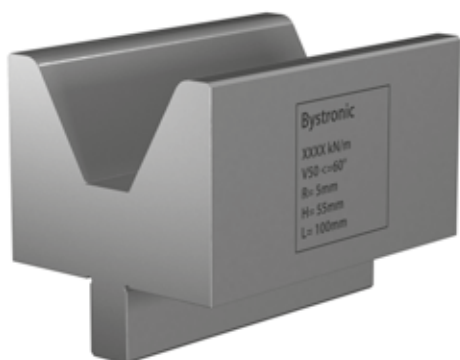

[R] säde (mm)*	5
[a] V - kulma	60°
[H] korkeus (mm)	55

[B] leveys (mm)	70
[D] syvyys (mm)	30.3

*Muut säteet tilauksesta

Vakiopituus	Osanumero
50 mm	64208.0050.5001
55 mm	64208.0050.5002
60 mm	64208.0050.5003
65 mm	64208.0050.5004
70 mm	64208.0050.5005
75 mm	64208.0050.5006
80 mm	64208.0050.5007
85 mm	64208.0050.5008
90 mm	64208.0050.5009
95 mm	64208.0050.5010
100 mm	64208.0050.5011

Vakiopituus	Osanumero
200 mm	64208.0050.5012
275 mm	64208.0050.5013
300 mm	64208.0050.5014
515 mm	64208.0050.5015
1025 mm sect.	64208.0050.5000



F max 60° = 1200 kN/m



24.5 kg/m



Sisämatriisi 13 mm



V50C/60° H100

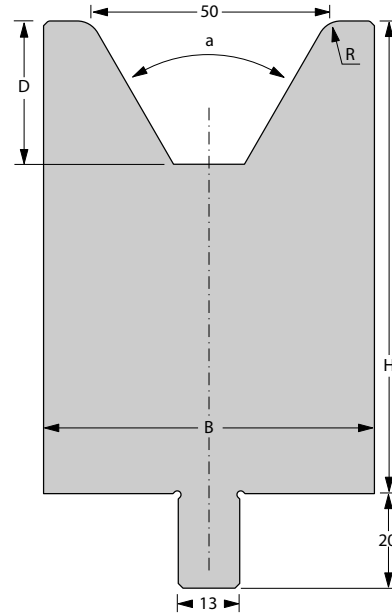

[R] säde (mm)*	5
[a] V - kulma	60°
[H] korkeus (mm)	100

[B] leveys (mm)	70
[D] syvyys (mm)	30.3

*Muut säteet tilauksesta

Vakiopituus	Osanumero
50 mm	64208.0050.5016
55 mm	64208.0050.5017
60 mm	64208.0050.5018
65 mm	64208.0050.5019
70 mm	64208.0050.5020
75 mm	64208.0050.5021
80 mm	64208.0050.5022
85 mm	64208.0050.5023
90 mm	64208.0050.5024
95 mm	64208.0050.5025
100 mm	64208.0050.5026

Vakiopituus	Osanumero
200 mm	64208.0050.5027
275 mm	64208.0050.5028
300 mm	64208.0050.5029
515 mm	64208.0050.5031
1025 mm sect.	64208.0050.5030



F max 60° = 2000 kN/m



49.2 kg/m



Sisämatriisi 13 mm



V60C/60° H65

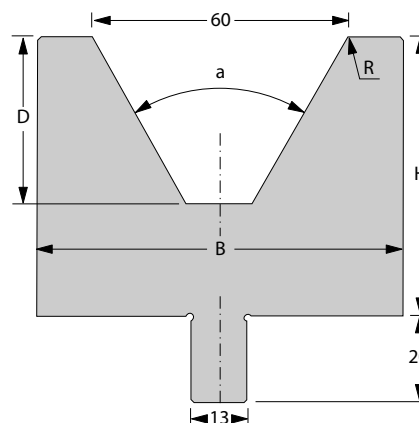
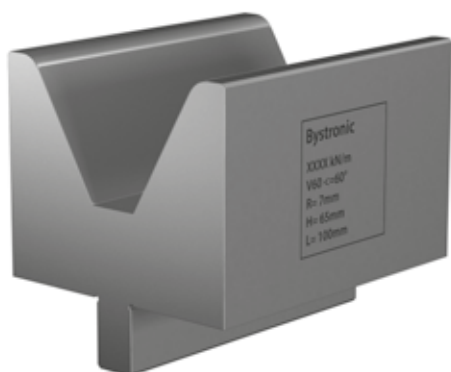

[R] säde (mm)*	7
[a] V - kulma	60°
[H] korkeus (mm)	65

[B] leveys (mm)	80
[D] syvyys (mm)	39

*Muut säteet tilauksesta

Vakiopituus	Osanumero
50 mm	64208.0060.5001
55 mm	64208.0060.5002
60 mm	64208.0060.5003
65 mm	64208.0060.5004
70 mm	64208.0060.5005
75 mm	64208.0060.5006
80 mm	64208.0060.5007
85 mm	64208.0060.5008
90 mm	64208.0060.5009
95 mm	64208.0060.5010
100 mm	64208.0060.5011

Vakiopituus	Osanumero
200 mm	64208.0060.5012
275 mm	64208.0060.5013
300 mm	64208.0060.5014
515 mm	64208.0060.5031
1025 mm sect.	64208.0060.5000



F max 60° = 1600 kN/m



31.4 kg/m



Sisämatriisi 13 mm



V60C/60° H100

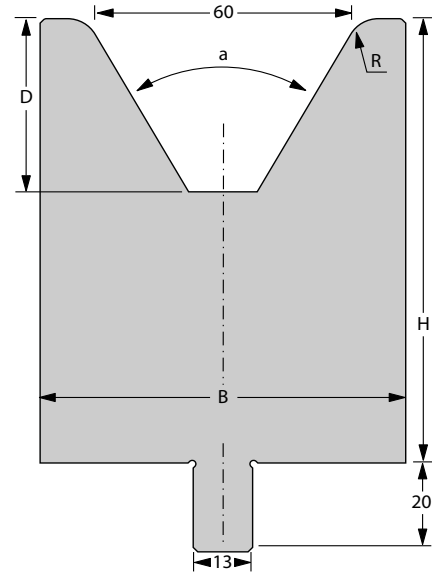

[R] säde (mm)*	7
[a] V - kulma	60°
[H] korkeus (mm)	100

[B] leveys (mm)	80
[D] syvyys (mm)	39

*Muut säteet tilauksesta

Vakiopituus	Osanumero
50 mm	64208.0060.5016
55 mm	64208.0060.5017
60 mm	64208.0060.5018
65 mm	64208.0060.5019
70 mm	64208.0060.5020
75 mm	64208.0060.5021
80 mm	64208.0060.5022
85 mm	64208.0060.5023
90 mm	64208.0060.5024
95 mm	64208.0060.5025
100 mm	64208.0060.5026

Vakiopituus	Osanumero
200 mm	64208.0060.5015
275 mm	64208.0060.5027
300 mm	64208.0060.5028
1025 mm sect.	64208.0060.5030



F max 60° = 2000 kN/m



53.4 kg/m



Sisämatriisi 13 mm



V80C/80° H65

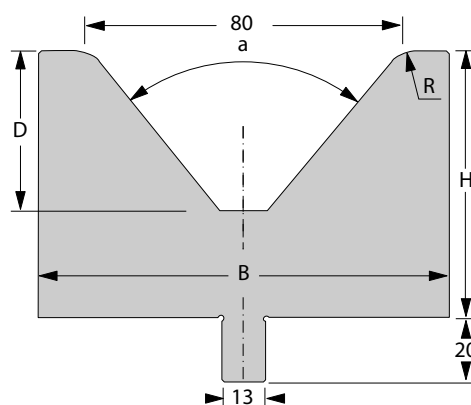
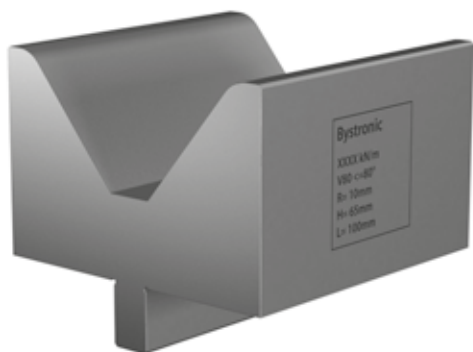

[R] säde (mm)*	10
[a] V - kulma	80°
[H] korkeus (mm)	65

[B] leveys (mm)	100
[D] syvyys (mm)	38.7

*Muut säteet tilauksesta

Vakiopituus	Osanumero
50 mm	64208.0080.5001
55 mm	64208.0080.5002
60 mm	64208.0080.5003
65 mm	64208.0080.5004
70 mm	64208.0080.5005
75 mm	64208.0080.5006
80 mm	64208.0080.5007
85 mm	64208.0080.5008
90 mm	64208.0080.5009
95 mm	64208.0080.5010
100 mm	64208.0080.5011

Vakiopituus	Osanumero
200 mm	64208.0080.5012
275 mm	64208.0080.5013
300 mm	64208.0080.5014
515 mm	64208.0080.5029
1025 mm sect.	64208.0080.5000



F max 80° = 1400 kN/m



38.6 kg/m



Sisämatriisi 13 mm



V80C/80° H100

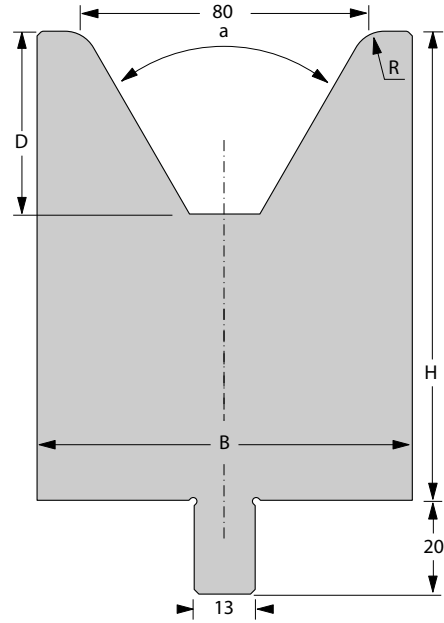

[R] säde (mm)*	10
[a] V - kulma	80°
[H] korkeus (mm)	100

[B] leveys (mm)	100
[D] syvyys (mm)	38.7

*Muut säteet tilauksesta

Vakiopituus	Osanumero
50 mm	64208.0080.5015
55 mm	64208.0080.5016
60 mm	64208.0080.5017
65 mm	64208.0080.5018
70 mm	64208.0080.5019
75 mm	64208.0080.5020
80 mm	64208.0080.5021
85 mm	64208.0080.5022
90 mm	64208.0080.5023
95 mm	64208.0080.5024
100 mm	64208.0080.5025

Vakiopituus	Osanumero
200 mm	64208.0080.5026
275 mm	64208.0080.5027
300 mm	64208.0080.5028
1025 mm sect.	64208.0080.5030



F max 80° = 1400 kN/m



66.0 kg/m



Sisämatriisi 13 mm



V100C/80° H85

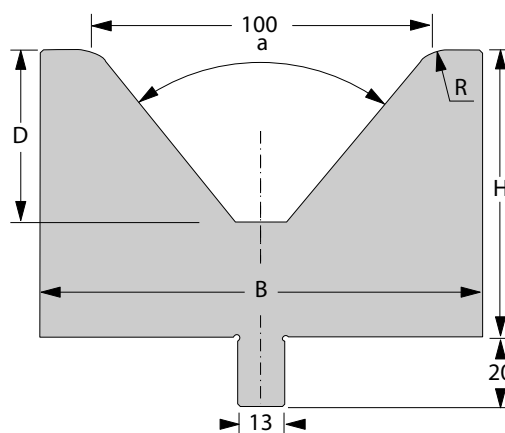
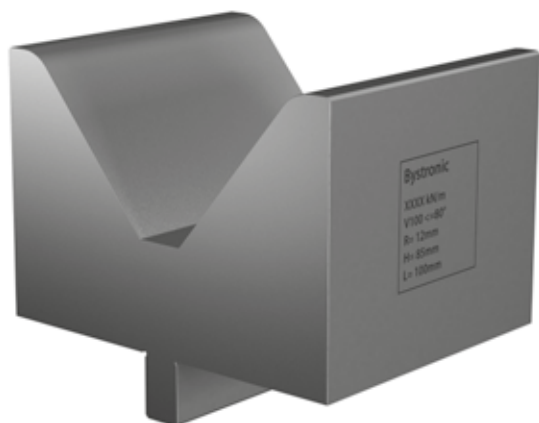

[R] säde (mm)*	12
[a] V - kulma	80°
[H] korkeus (mm)	85

[B] leveys (mm)	125
[D] syvyys (mm)	50.5

*Muut säteet tilauksesta

Vakiopituus	Osanumero
50 mm	64208.0100.5001
55 mm	64208.0100.5002
60 mm	64208.0100.5003
65 mm	64208.0100.5004
70 mm	64208.0100.5005
75 mm	64208.0100.5006
80 mm	64208.0100.5007
85 mm	64208.0100.5008
90 mm	64208.0100.5009
95 mm	64208.0100.5010
100 mm	64208.0100.5011

Vakiopituus	Osanumero
200 mm	64208.0100.5012
275 mm	64208.0100.5013
300 mm	64208.0100.5014
1025 mm sect.	64208.0100.5000



F max 80° = 1800 kN/m



60.5 kg/m



Sisämatriisi 13 mm



V120C/80° H105

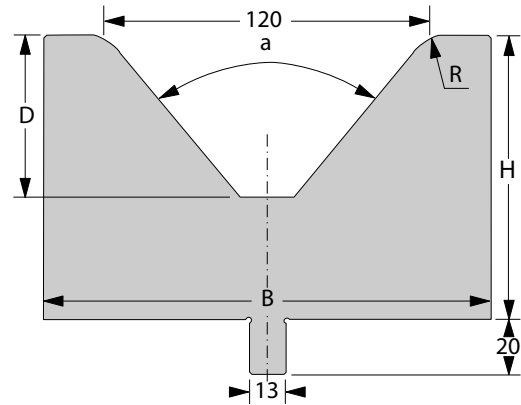
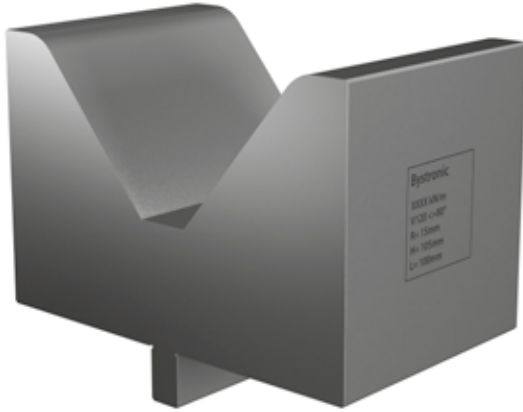

[R] säde (mm)*	15
[a] V - kulma	80°
[H] korkeus (mm)	105

[B] leveys (mm)	160
[D] syvyys (mm)	59.5

*Muut säteet tilauksesta

Vakiopituus	Osanumero
50 mm	64208.0120.5001
55 mm	64208.0120.5002
60 mm	64208.0120.5003
65 mm	64208.0120.5004
70 mm	64208.0120.5005
75 mm	64208.0120.5006
80 mm	64208.0120.5007
85 mm	64208.0120.5008
90 mm	64208.0120.5009
95 mm	64208.0120.5010
100 mm	64208.0120.5011

Vakiopituus	Osanumero
200 mm	64208.0120.5012
275 mm	64208.0120.5013
300 mm	64208.0120.5014
1025 mm sect.	64208.0120.5000



F max 80° = 2000 kN/m



101.0 kg/m



Sisämatriisi 13 mm



V6SC/30° H55

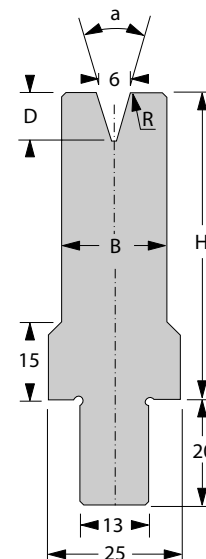

[R] säde (mm)*	0.75
[a] V - kulma	30°
[H] korkeus (mm)	55

[B] leveys (mm)	12
[D] syvyys (mm)	9.3

*Muut säteet tilauksesta

Vakiopituus	Osanumero
50 mm	64208.0006.5101
55 mm	64208.0006.5102
60 mm	64208.0006.5103
65 mm	64208.0006.5104
70 mm	64208.0006.5105
75 mm	64208.0006.5106
80 mm	64208.0006.5107
85 mm	64208.0006.5108
90 mm	64208.0006.5109
95 mm	64208.0006.5110
100 mm	64208.0006.5111

Vakiopituus	Osanumero
200 mm	64208.0006.5112
275 mm	64208.0006.5113
300 mm	64208.0006.5114
515 mm	64208.0006.5115
1025 mm sect.	64208.0006.5100



F max 30° = 100 kN/m



8.1 kg/m



Sisämatriisi 13 mm



V6SC/30° H100

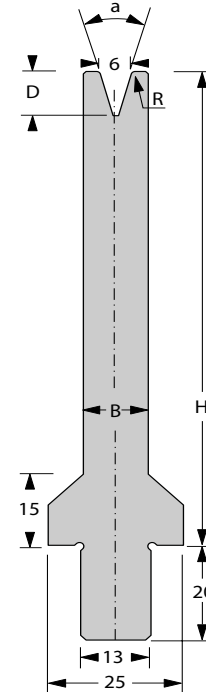

[R] säde (mm)*	0.75
[a] V - kulma	30°
[H] korkeus (mm)	100

[B] leveys (mm)	12
[D] syvyys (mm)	9.3

*Muut säteet tilauksesta

Vakiopituus	Osanumero
50 mm	64208.0006.5151
55 mm	64208.0006.5152
60 mm	64208.0006.5153
65 mm	64208.0006.5154
70 mm	64208.0006.5155
75 mm	64208.0006.5156
80 mm	64208.0006.5157
85 mm	64208.0006.5158
90 mm	64208.0006.5159
95 mm	64208.0006.5160
100 mm	64208.0006.5161

Vakiopituus	Osanumero
200 mm	64208.0006.5162
275 mm	64208.0006.5163
300 mm	64208.0006.5164
515 mm	64208.0006.5165
1025 mm sect.	64208.0006.5150



$F_{max} 30^\circ = 100 \text{ kN/m}$



12.3 kg/m



Sisämatriisi 13 mm



V8SC/30° H55

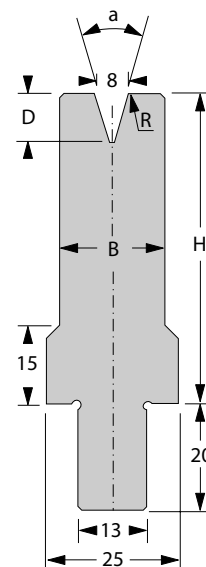

[R] säde (mm)*	1
[a] V - kulma	30°
[H] korkeus (mm)	55

[B] leveys (mm)	14
[D] syvyys (mm)	11.2

*Muut säteet tilauksesta

Vakiopituus	Osanumero
50 mm	64208.0008.5102
55 mm	64208.0008.5103
60 mm	64208.0008.5104
65 mm	64208.0008.5105
70 mm	64208.0008.5106
75 mm	64208.0008.5107
80 mm	64208.0008.5108
85 mm	64208.0008.5109
90 mm	64208.0008.5110
95 mm	64208.0008.5111
100 mm	64208.0008.5112

Vakiopituus	Osanumero
200 mm	64208.0008.5113
275 mm	64208.0008.5114
300 mm	64208.0008.5115
515 mm	64208.0008.5116
1025 mm sect.	64208.0008.5100



F max 30° = 100 kN/m



8.7 kg/m



Sisämatriisi 13 mm



V8SC/30° H100

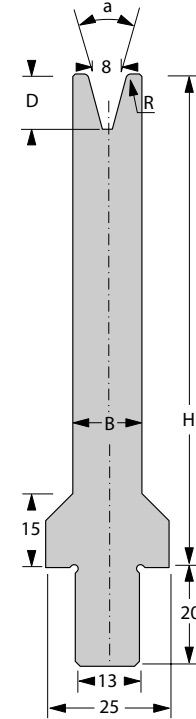

[R] säde (mm)*	1
[a] V - kulma	30°
[H] korkeus (mm)	100

[B] leveys (mm)	14
[D] syvyys (mm)	11.2

*Muut säteet tilauksesta

Vakiopituus	Osanumero
50 mm	64208.0008.5151
55 mm	64208.0008.5152
60 mm	64208.0008.5153
65 mm	64208.0008.5154
70 mm	64208.0008.5155
75 mm	64208.0008.5156
80 mm	64208.0008.5157
85 mm	64208.0008.5158
90 mm	64208.0008.5159
95 mm	64208.0008.5160
100 mm	64208.0008.5161

Vakiopituus	Osanumero
200 mm	64208.0008.5162
275 mm	64208.0008.5163
300 mm	64208.0008.5164
515 mm	64208.0008.5166
1025 mm sect.	64208.0008.5150



$F_{max} 30^\circ = 1000 \text{ kN/m}$



13.7 kg/m



Sisämatriisi 13 mm



V10SC/30° H55

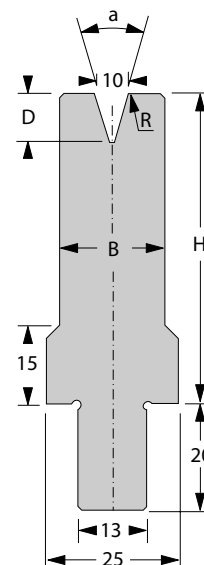

[R] säde (mm)*	1
[a] V - kulma	30°
[H] korkeus (mm)	55

[B] leveys (mm)	16
[D] syvyys (mm)	14.9

*Muut säteet tilauksesta

Vakiopituus	Osanumero
50 mm	64208.0010.5101
55 mm	64208.0010.5102
60 mm	64208.0010.5103
65 mm	64208.0010.5104
70 mm	64208.0010.5105
75 mm	64208.0010.5106
80 mm	64208.0010.5107
85 mm	64208.0010.5108
90 mm	64208.0010.5109
95 mm	64208.0010.5110
100 mm	64208.0010.5111

Vakiopituus	Osanumero
200 mm	64208.0010.5112
275 mm	64208.0010.5113
300 mm	64208.0010.5114
515 mm	64208.0010.5115
1025 mm sect.	64208.0010.5100



F max 30° = 100 kN/m



9.1 kg/m



Sisämatriisi 13 mm



V10SC/30° H100

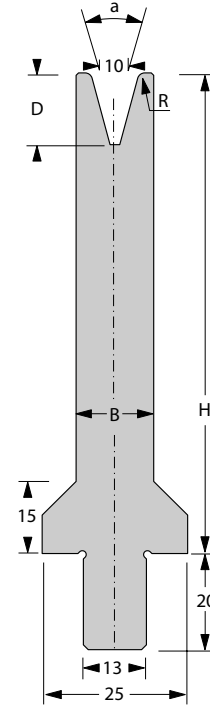

[R] säde (mm)*	1
[a] V - kulma	30°
[H] korkeus (mm)	100

[B] leveys (mm)	16
[D] syvyys (mm)	14.9

*Muut säteet tilauksesta

Vakiopituus	Osanumero
50 mm	64208.0010.5117
55 mm	64208.0010.5118
60 mm	64208.0010.5119
65 mm	64208.0010.5120
70 mm	64208.0010.5121
75 mm	64208.0010.5122
80 mm	64208.0010.5123
85 mm	64208.0010.5124
90 mm	64208.0010.5125
95 mm	64208.0010.5126
100 mm	64208.0010.5127

Vakiopituus	Osanumero
200 mm	64208.0010.5128
275 mm	64208.0010.5129
300 mm	64208.0010.5130
515 mm	64208.0010.5131
1025 mm sect.	64208.0010.5116



F max 30° = 100 kN/m



14.7 kg/m



Sisämatriisi 13 mm



V12SC/30° H55

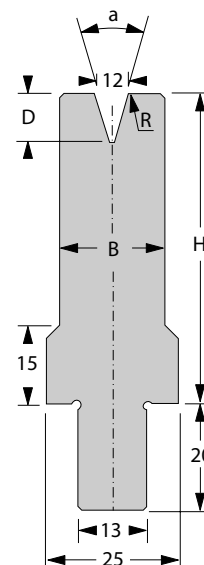
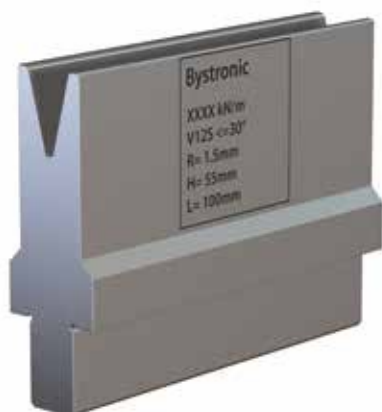

[R] säde (mm)*	1.5
[a] V - kulma	30°
[H] korkeus (mm)	55

[B] leveys (mm)	18
[D] syvyys (mm)	18.6

*Muut säteet tilauksesta

Vakiopituus	Osanumero
50 mm	64208.0012.5101
55 mm	64208.0012.5102
60 mm	64208.0012.5103
65 mm	64208.0012.5104
70 mm	64208.0012.5105
75 mm	64208.0012.5106
80 mm	64208.0012.5107
85 mm	64208.0012.5108
90 mm	64208.0012.5109
95 mm	64208.0012.5110
100 mm	64208.0012.5111

Vakiopituus	Osanumero
200 mm	64208.0012.5112
275 mm	64208.0012.5113
300 mm	64208.0012.5114
515 mm	64208.0012.5115
1025 mm sect.	64208.0012.5100



F max 30° = 100 kN/m



9.5 kg/m



Sisämatriisi 13 mm



V12SC/30° H100

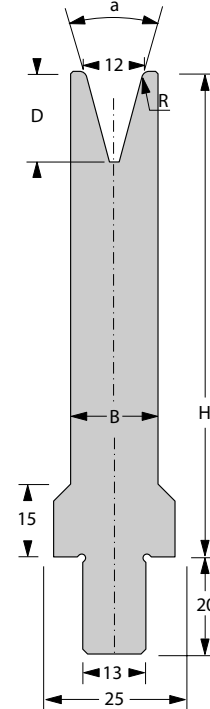

[R] säde (mm)*	1.5
[a] V - kulma	30°
[H] korkeus (mm)	100

[B] leveys (mm)	18
[D] syvyys (mm)	18.6

*Muut säteet tilauksesta

Vakiopituus	Osanumero
50 mm	64208.0012.5117
55 mm	64208.0012.5118
60 mm	64208.0012.5119
65 mm	64208.0012.5120
70 mm	64208.0012.5121
75 mm	64208.0012.5122
80 mm	64208.0012.5123
85 mm	64208.0012.5124
90 mm	64208.0012.5125
95 mm	64208.0012.5126
100 mm	64208.0012.5127

Vakiopituus	Osanumero
200 mm	64208.0012.5128
275 mm	64208.0012.5129
300 mm	64208.0012.5130
515 mm	64208.0012.5131
1025 mm sect.	64208.0012.5116



F max 30° = 100 kN/m



15.9 kg/m



Sisämatriisi 13 mm



Taittotyökalut

Litistystyökalut

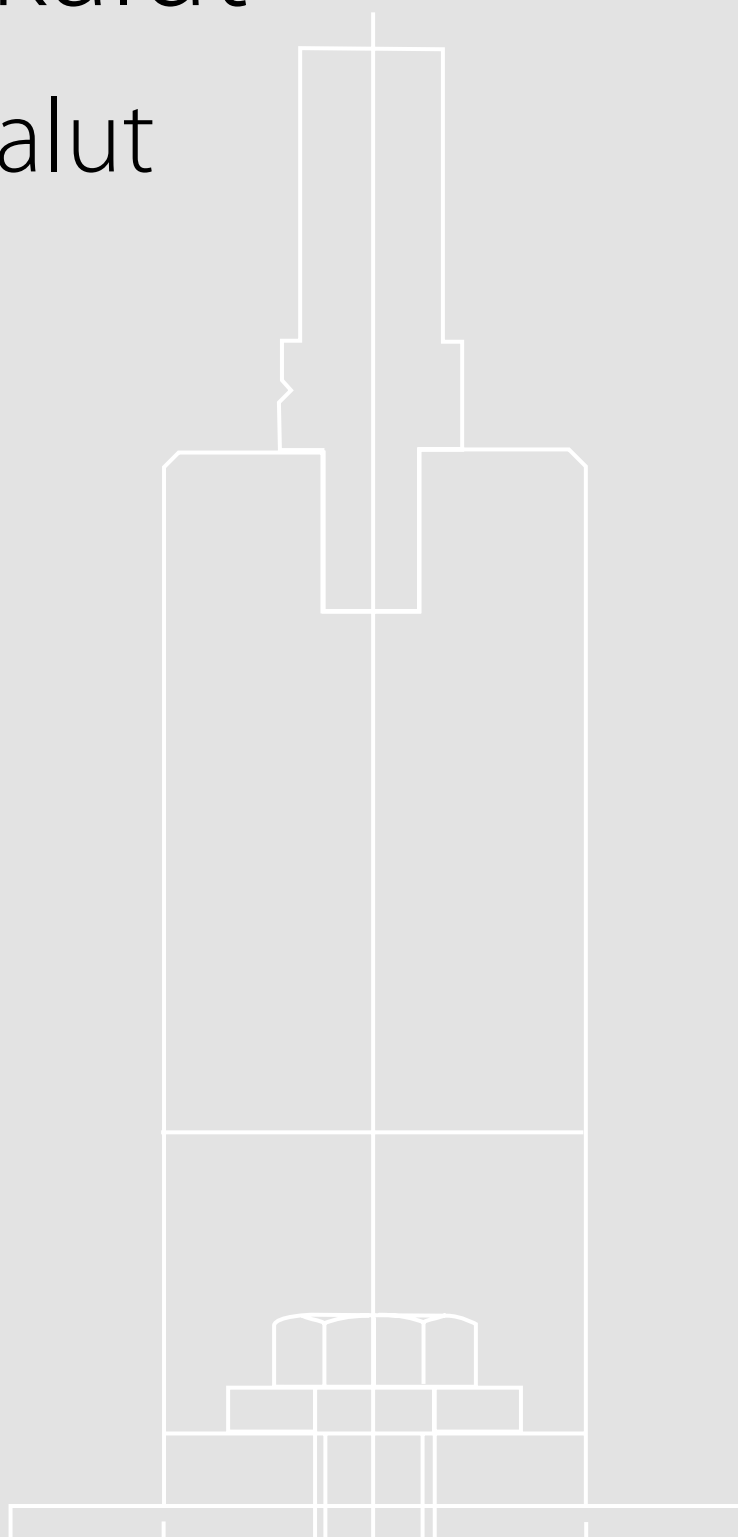





P11 RF-AC H250

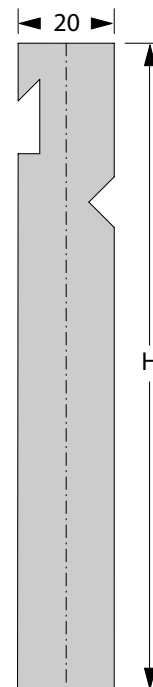

[B] leveys (mm)	20
[H] korkeus (mm)	250

Vakiopituus	Osanumero
30 mm	65208.0011.5001
35 mm	65208.0011.5002
40 mm	65208.0011.5003
45 mm	65208.0011.5004
50 mm	65208.0011.5005
55 mm	65208.0011.5006
60 mm	65208.0011.5007
65 mm	65208.0011.5008
70 mm	65208.0011.5009
75 mm	65208.0011.5010
80 mm	65208.0011.5011

Vakiopituus	Osanumero
85 mm	65208.0011.5012
90 mm	65208.0011.5013
95 mm	65208.0011.5014
100 mm	65208.0011.5015
200 mm	65208.0011.5016
275 mm	65208.0011.5017
300 mm	65208.0011.5018
515 mm	65208.0011.5023
1175 mm sect.	65208.0011.5000



F max = 1400 kN/m



35.9 kg/m



98.0 mm



P900/8 RF-AC/30° H250

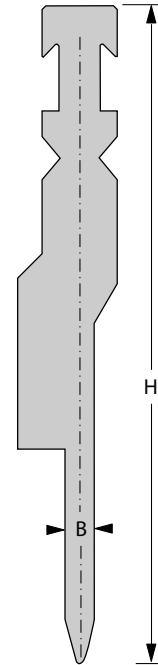

[B] leveys (mm)	26.5
[H] korkeus (mm)	250

Vakiopituus	Osanumero
30 mm	65208.0900.5002
35 mm	65208.0900.5003
40 mm	65208.0900.5004
45 mm	65208.0900.5005
50 mm	65208.0900.5006
55 mm	65208.0900.5007
60 mm	65208.0900.5008
65 mm	65208.0900.5009
70 mm	65208.0900.5010
75 mm	65208.0900.5011
80 mm	65208.0900.5012

Vakiopituus	Osanumero
85 mm	65208.0900.5013
90 mm	65208.0900.5014
95 mm	65208.0900.5015
100 mm	65208.0900.5016
200 mm	65208.0900.5017
275 mm	65208.0900.5018
300 mm	65208.0900.5019
515 mm	65208.0900.5020
1175 mm sect.	65208.0900.5000



$F_{max} = 1000 \text{ kN/m}$



29.2 kg/m



P900/10 RF-AC/30° H250

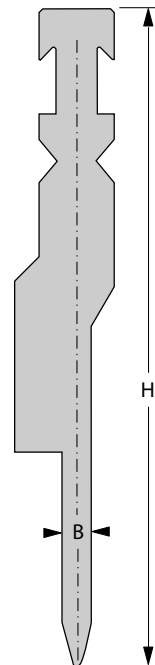

[B] leveys (mm) 26.5

[H] korkeus (mm) 250

Vakiopituus	Osanumero
30 mm	65208.0900.5050
35 mm	65208.0900.5041
40 mm	65208.0900.5042
45 mm	65208.0900.5043
50 mm	65208.0900.5044
55 mm	65208.0900.5045
60 mm	65208.0900.5046
65 mm	65208.0900.5047
70 mm	65208.0900.5048
75 mm	65208.0900.5049
80 mm	65208.0900.5040

Vakiopituus	Osanumero
85 mm	65208.0900.5051
90 mm	65208.0900.5052
95 mm	65208.0900.5053
100 mm	65208.0900.5054
200 mm	65208.0900.5055
275 mm	65208.0900.5056
300 mm	65208.0900.5057
515 mm	65208.0900.5058
1175 mm sect.	65208.0900.5059



F max = 1000 kN/m



29.2 kg/m



P900/12 RF-AC/30° H250

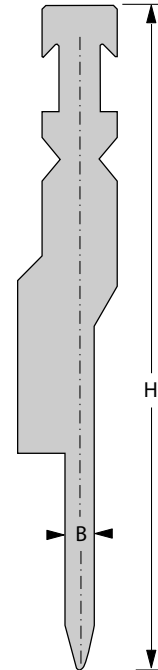

[B] leveys (mm)	26.5
[H] korkeus (mm)	250

Vakiopituus	Osanumero
30 mm	65208.0900.5021
35 mm	65208.0900.5022
40 mm	65208.0900.5023
45 mm	65208.0900.5024
50 mm	65208.0900.5025
55 mm	65208.0900.5026
60 mm	65208.0900.5027
65 mm	65208.0900.5028
70 mm	65208.0900.5029
75 mm	65208.0900.5030
80 mm	65208.0900.5031

Vakiopituus	Osanumero
85 mm	65208.0900.5032
90 mm	65208.0900.5033
95 mm	65208.0900.5034
100 mm	65208.0900.5035
200 mm	65208.0900.5036
275 mm	65208.0900.5037
300 mm	65208.0900.5001
515 mm	65208.0900.5038
1175 mm sect.	65208.0900.5039



F max = 1000 kN/m



34.3 kg/m



V-Flat B40

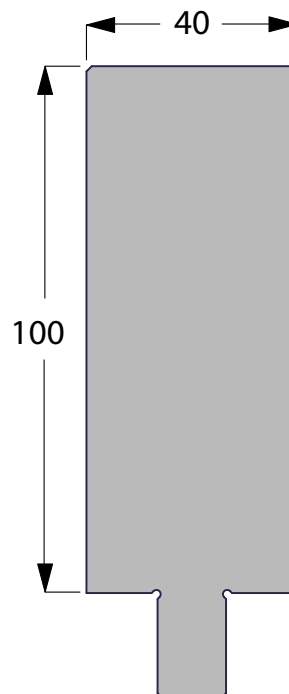

[B] leveys (mm)	40
[H] korkeus (mm)	100

Vakiopituus	Osanumero
50 mm	64208.0000.5001
55 mm	64208.0000.5002
60 mm	64208.0000.5003
65 mm	64208.0000.5004
70 mm	64208.0000.5005
75 mm	64208.0000.5006
80 mm	64208.0000.5007
85 mm	64208.0000.5008
90 mm	64208.0000.5009
95 mm	64208.0000.5010
100 mm	64208.0000.5011

Vakiopituus	Osanumero
200 mm	64208.0000.5012
275 mm	64208.0000.5013
300 mm	64208.0000.5014
515 mm	64208.0000.5015
1025 mm sect.	64208.0000.5000



F max 30° = 2000 kN/m



35.5 kg/m



Sisämatriisi 13 mm



V900/08C

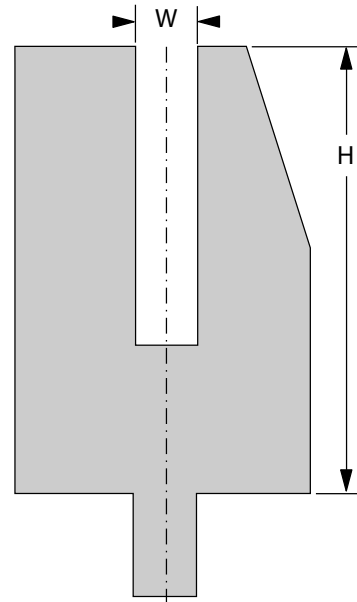

[B] leveys (mm)	55
[H] korkeus (mm)	85

Vakiopituus	Osanumero
50 mm	64208.0900.5003
55 mm	64208.0900.5004
60 mm	64208.0900.5005
65 mm	64208.0900.5006
70 mm	64208.0900.5007
75 mm	64208.0900.5008
80 mm	64208.0900.5009
85 mm	64208.0900.5010
90 mm	64208.0900.5011
95 mm	64208.0900.5012
100 mm	64208.0900.5013

Vakiopituus	Osanumero
200 mm	64208.0900.5014
275 mm	64208.0900.5015
300 mm	64208.0900.5002
515 mm	64208.0900.5016
1025 mm sect.	64208.0900.5000



$F_{max} 30^\circ = 250 \text{ kN/m}$



35.5 kg/m



Sisämatriisi 13 mm



V900/10C

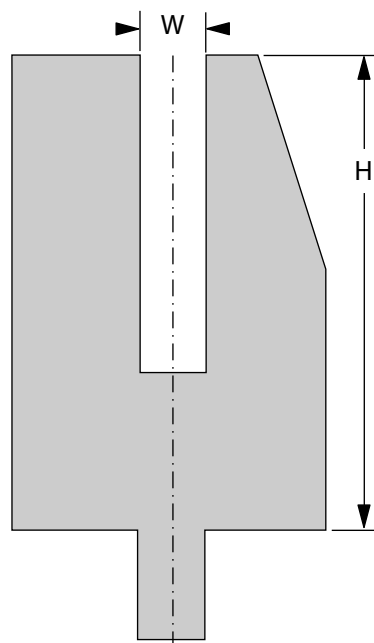

[B] leveys (mm)	55
[H] korkeus (mm)	85

Vakiopituus	Osanumero
50 mm	64208.0900.5032
55 mm	64208.0900.5033
60 mm	64208.0900.5034
65 mm	64208.0900.5047
70 mm	64208.0900.5035
75 mm	64208.0900.5036
80 mm	64208.0900.5037
85 mm	64208.0900.5038
90 mm	64208.0900.5039
95 mm	64208.0900.5040
100 mm	64208.0900.5041

Vakiopituus	Osanumero
200 mm	64208.0900.5042
275 mm	64208.0900.5043
300 mm	64208.0900.5044
515 mm	64208.0900.5045
1025 mm sect.	64208.0900.5046



F max 30° = 250 kN/m



32.0 kg/m



Sisämatriisi 13 mm



V900/12C

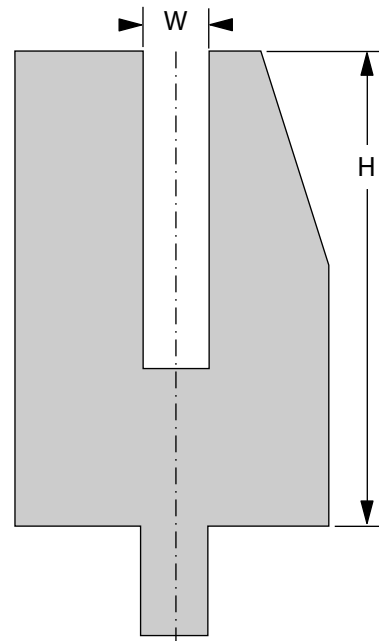

[B] leveys (mm)	55
[H] korkeus (mm)	85

Vakiopituus	Osanumero
50 mm	64208.0900.5017
55 mm	64208.0900.5018
60 mm	64208.0900.5019
65 mm	64208.0900.5020
70 mm	64208.0900.5021
75 mm	64208.0900.5022
80 mm	64208.0900.5023
85 mm	64208.0900.5024
90 mm	64208.0900.5025
95 mm	64208.0900.5026
100 mm	64208.0900.5027

Vakiopituus	Osanumero
200 mm	64208.0900.5028
275 mm	64208.0900.5029
300 mm	64208.0900.5001
515 mm	64208.0900.5030
1025 mm sect.	64208.0900.5031



$F_{max} 30^\circ = 250 \text{ kN/m}$



31.0 kg/m



Sisämatriisi 13 mm



Yhteystietomme kautta maailman

Bystronic Laser AG

Industriestrasse 21
3362 Niederönz
Sveitsi
Puh. +41 62 956 33 33
Sähköposti info.laser@bystronic.com

Bystronic Australia Pty. Ltd.

4 Latchford Street
Cranbourne West VIC 3977
Australia
Puh.: +61 1300 975 761
Sähköposti info.au@bystronic.com

Bystronic Austria GmbH

Schärdinger Straße 15
4061 Pasching
Itävalta
Puh. +43 7229 64411
Sähköposti office.at@bystronic.com

Bystronic do Brasil Ltda.

Rua Parma 203
83413-587 – Colombo – PR
Brasilia
Puh. +55 41 3666 9000
Sähköposti bystronic.br@bystronic.com

Bystronic Canada Ltd

3330 Ridgeway Drive, Unit #11
Mississauga, ON L5L 5Z9
Kanada
Puh: +1 905 890 2999
Sähköposti sales.canada@bystronic.com

Bystronic (Tianjin) Laser Ltd.

No. 46 Xishi Road
Airport Industrial Park
300308 Tianjin
Kiina
Puh: +86 22 5980 1888
Sähköposti info.tj.cn@bystronic.com

Bystronic Czech Republic s.r.o.

Turanka 115/1222
627 00 Brno Slatina
Tšekin tasavalta
Puh. +420 532 123 314
Sähköposti info.cz@bystronic.com

Bystronic Ibérica, S.A.

Avda. Tenerife n° 2
Edificio 1, Planta 3, Oficina D
28700 San Sebastián de los Reyes
(Madrid) Espanja
Puh. +34 91 654 48 78
Sähköposti sales.es@bystronic.com

Bystronic France SAS

Parc Technopolis
3, Avenue du Canada
91940 Les Ulis Cedex
Ranska
Puh. +33 1 69 41 99 84
Sähköposti info.fr@bystronic.com

Bystronic Maschinenbau GmbH

Mühlhäuser Strasse 3
99867 Gotha
Saksa
Puh. +49 3621 38 30
Sähköposti info.bending@bystronic.com

Bystronic Deutschland GmbH

Römerstrasse 14
71296 Heimsheim
Saksa
Puh. +49 7033 46 99 0
Sähköposti info.de@bystronic.com

Bystronic Magyarország Kft.

Budaörs Business Center
Puskás Tivadarút 5
2040 Budaörs
Unkari
Puh: +36 23 610 433
Sähköposti info.hu@bystronic.com

Bystronic Laser India (Pvt) Ltd.

7C, Tadiwala Road
Next to Hotel Pancharatna
Pune 411 001
Intia
Puh: +91 20 67294800
Sähköposti info.in@bystronic.com

Bystronic Italia SRL

Via del Lavoro, 30
20813 Bovisio-Masciago
Italia
Puh. +39 0362 5993 1
Sähköposti sales.it@bystronic.com

Bystronic Japan, Ltd.

2-95-3 Inadaira Musashimurayama-shi
Tokyo 208-0023
Japani
Puh: +81 42 506 8271
Sähköposti Cesar.Mujica@bystronic.com

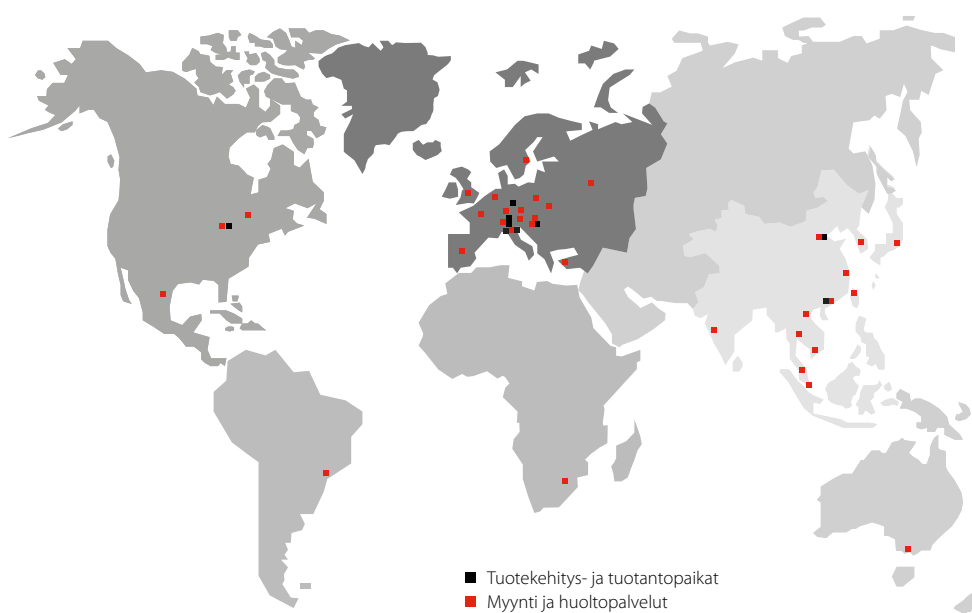

■ Tuotekehitys- ja tuotantopaikat
■ Myynti ja huoltopalvelut



Bystronic Laser Pte. Ltd.

(edustaja)
Level 8, MCT Tower, Sky Park,
One City, Jalan USJ 25/1
Subang Jaya
47650 Selangor
Malesia
Puh: +60 3 8022 8268

Bystronic Mexico S.A. de C.V.

Helios 401 A, Parque Industrial FINSA
Apodaca
66600 Nuevo León
Meksiko
Puh. +52 81 2133 7600
Sähköposti sales.mexico@bystronic.com

Bystronic Benelux B.V.

Duurzaamheidsring 11
4231 EX Meerkerk
Alankomaat
Puh. +31 184 611 020
Sähköposti sales.benelux@bystronic.com

Bystronic Korea, Ltd.

3F Bystronic Bldg,
32-18, LS-ro
91 Beon-gil, Dongan-gu Anyang-si
14119 Gyeonggi-do
Korea
Puh. +82 31 389 9800
Sähköposti info.kr@bystronic.com

Bystronic Polska Sp. z o.o.

Ul. Sokolowska 47
PL-05-806 Sokolów
Puola
Puh. +48 22 331 37 70
Sähköposti info.pl@bystronic.com

S.C. Bystronic Laser S.R.L.

Str. Poienelor no. 5
Industrial Pro Roman Park
500419 Brasov
Romania
Puh: +40 268 322 140
Sähköposti info.ro@bystronic.com

Bystronic Laser

Zorge Street, 9A
Stroenie 2 (Building 2)
125252 Moscow
Venäjä
Puh: +7 495 984 71 44
Sähköposti info.ru@bystronic.com

Bystronic Co., Ltd. (Shanghai)

Room 602, Part A,
No. 388 North Fu Quan Road
Changning District
Shanghai, 200335
Puh. +86 21 6082 9300
Sähköposti info.sha.cn@bystronic.com

Bystronic Pte. Ltd.

Thye Hong Centre
2 Leng Kee Road #02-04
159086 Singapore
Puh. +65 6472 6300
Sähköposti info.sg@bystronic.com

Bystronic Scandinavia AB

Metallvägen 30A
195 72 Rosersberg
Ruotsi
Puh: +46 (0)8 594 415 50
Sähköposti Services.SE@bystronic.com

Bystronic Sales AG

Industriestrasse 21
3362 Niederönz
Sveitsi
Puh. +41 62 956 37 83
Sähköposti info.sales@bystronic.com

Bystronic International Laser Ltd.

No. 66, Wuquan Rd.,
Wugu Dist.,
New Taipei City 248
Taiwan (R.O.C)
Puh: +886 2 2299 2699
Sähköposti hotline.tw@bystronic.com

Bystronic Lazer ve Su Isinlari

Makineleri Sanayi ve Ticaret Ltd. Sti.
Serifali Mevkii, Barbaros Caddesi
No: 66 K:1
34775 Ümraniye/Istanbul
Turkki
Puh: +90 216 464 6160
Sähköposti info.tr@bystronic.com

LLC Bystronic Ukraine

59 Zhylyanskaya Street
Diplomat Hall, 2nd floor, Office 207
1033 Kiova
Ukraina
Puh. +380 44 569 74 37
Sähköposti info.cis@bystronic.com

Bystronic UK Ltd.

6 Wayside Business Park
Wilson's Lane
Coventry
Warwickshire CV6 6NY
Britannia
Puh: +44 (0)844 848 5850
Sähköposti sales.uk@bystronic.com

Bystronic Inc.

2200 West Central Road
US-Hoffman Estates
IL 60192
USA
Puh. +1 847 214 0300
Sähköposti sales.us@bystronic.com

Bystronic Vietnam Co. Ltd.

38/7 Truong Chinh Str.
Tan Thoi Nhat Ward
District 12
Hochiminh City
Vietnam
Puh: +84 28 3719 2278
Sähköposti Anhtuan.Ha@bystronic.com

